



Thank You for purchasing this

Factory Service Manual on EBAY

from PCTECHINFO!



[Click Here](#) for more Factory Service

Manuals for other Computer and

Printer / Copier Manufacturers

from PCTECHINFO!

OKI

C9000 Series Color LED Page Printer Service Manual

ODA

05-18-200 Based on Rev.2

Document Revision History

Rev.No.	Date	Corrected items			Person in charge
		No.	Page	Description of change	
1	2000-12-05			ISSUE	EM3 Murakami
2	2000-12-13	8		Correction of errors in the parts list	K Yamazaki
3	05-18-2001			ODA Revisions	ODA Training

PREFACE

This maintenance manual provides procedures and techniques for the troubleshooting, maintenance, and repair of C9000.

This manual is written for maintenance personnel, but it should always be accompanied with the C9000 User's Manual for procedures for handling and operating C9000. For repairing each component of C9000, see the Troubleshooting manual.

[Notices]

The contents of this manual are subject to change without prior notice.

Although reasonable efforts have been taken in the preparation of this manual to assure its accuracy, this manual may still contain some errors and omissions. OKI will not be liable for any damage caused or alleged to be caused, by the customer or any other person using this maintenance manual to repair, modify, or alter C9000 in any manner.

[Warning]

Many parts of C9000 are very sensitive and can be easily damaged by improper servicing. We strongly suggest that C9000 be serviced by OKI's authorized technical service engineers.

CONTENTS

1. SPECIFICATIONS	7
1.1 Basic System Configuration	7
1.2 Printer Engine Specifications	8
1.3 Option Configuration	9
1.4 Specifications	10
2. OPERATION DESCRIPTION	12
2.1 Main Control Board (CRM-PWB)	13
2.2 Engine Control Board (K73 PWB)	15
2.3 Power Units	16
2.4 Mechanical Processes	17
2.4.1 Electrophotographic process	18
2.4.2 Paper running process	22
2.5 Sensor	31
2.5.1 Paper related sensors	31
2.5.2 Other sensors	32
2.6 Color Misalignment Correction	33
2.7 Transfer Control Responds to Environmental Changes (Room Temperatures and Relative Humidities)	33
2.8 Paper Jam Detection	34
2.9 Cover Opening	35
2.10 Toner Low Detection	36
2.11 Paper Size Detection	37
2.12 Operation at Power-on	38
2.12.1 Self-diagnostic test	38
2.13 Color Misalignment Detection	39
2.14 Version Read of Periodically Replaced Units	40
2.15 Life Counter for Replaceable Units	40
2.16 Toner Consumption Detection	40
3. PARTS REPLACEMENT	41
3.1 Precautions in Replacing Parts	41
3.2 Parts Layout	43
3.3 Replacing Parts	50
3.3.1 Top cover	51
3.3.2 LED Assy/ LED Assy spring	52
3.3.3 Top cover unit	53
3.3.4 Control panel Assy/ Control panel bezel/ LED control PWB/ Toner sensor/ Stack full sensor/ Control panel tape harness/ Eject roller	54
3.3.5 Top cover handle/ Tope cover latch/ Top cover latch spring	55
3.3.6 Eject guide Assy	56
3.3.7 Cassette Assy/ Blind cover/ Side cover R Assy	57
3.3.8 Feed rollers	58
3.3.9 Left side cover	59
3.3.10 Face-up tray	60
3.3.11 Front cover	61
3.3.12 Rear cover	62
3.3.13 Multipurpose tray Assy/ Multipurpose tray cover Assy/ Links/ Multipurpose tray top cover/ Multipurpose tray drive gear	63
3.3.14 Drum contact Assys	64
3.3.15 Registration roller Assy (A)/ Registration drive gear (A)	65

3.3.16	Registration roller Assy (B)	66
3.3.17	Registration clutch, Registration motor Assy	67
3.3.18	Cooling fan	68
3.3.19	Color registration sensor Assy	69
3.3.20	Duplex guide Assy	70
3.3.21	Electrical chassis/ Electrical chassis cooling fan	71
3.3.22	Printer engine controller PWB	72
3.3.23	Printer unit chassis	73
3.3.24	Entrance cassette sensor actuator	74
3.3.25	Entrance sensor PWB	75
3.3.26	Entrance MT sensor actuator and Entrance belt sensor actuator	76
3.3.27	Main motor fan/ Fuser eject roller	77
3.3.28	Eject sensor Assy	78
3.3.29	Fuser latching handle (L)	79
3.3.30	Belt motor Assy	80
3.3.31	Fuser latching handle (R)	81
3.3.32	Main motor Assy	82
3.3.33	Contact Assy/ Side plate Assy	83
3.3.34	Low voltage power supply	84
3.3.35	High voltage power supply	85
3.3.36	Main feed Assy	86
3.3.37	Fuser unit	87
3.3.38	Belt unit	88
3.3.39	Duplex unit	89
3.3.40	CU Assy	90
4.	Adjustment	92
4.1	Maintenance Menu and Its Functions	92
4.2	Short Plug Settings	93
4.3	Printing Singly Using Controller-Equipped Printer	93
4.4	Adjustment after Part Replacement	94
4.5	Color Balance Adjustment	95
4.6	EEPROM Replacement after CRM Board and K73 Board Replacement	97
5.	Regular Maintenance	98
5.1	Parts to be Replaced Regularly	98
5.2	Cleaning	98
5.3	Cleaning of LED Lens Array	98
5.4	Cleaning of Pick-up Roller	98
6.	TROUBLESHOOTING PROCEDURES	99
6.1	Tips for Troubleshooting	99
6.2	Check Points before Correcting Image Problems	99
6.3	Tips for Correcting Image Problems	99
6.4	Preparation for Troubleshooting	100
6.5	Troubleshooting Flow	100
6.5.1	LCD Message List	101
6.5.2	LCD message troubleshooting	106
6.5.3	Image troubleshooting	117
7.	WIRING DIAGRAM	129
7.1	Resistance Check	129
7.2	Parts Layout on Boards	134
8.	Parts List	138

1. SPECIFICATIONS

1.1 Basic System Configuration

The basic system configuration of C9000 is illustrated in Figure 1.1.

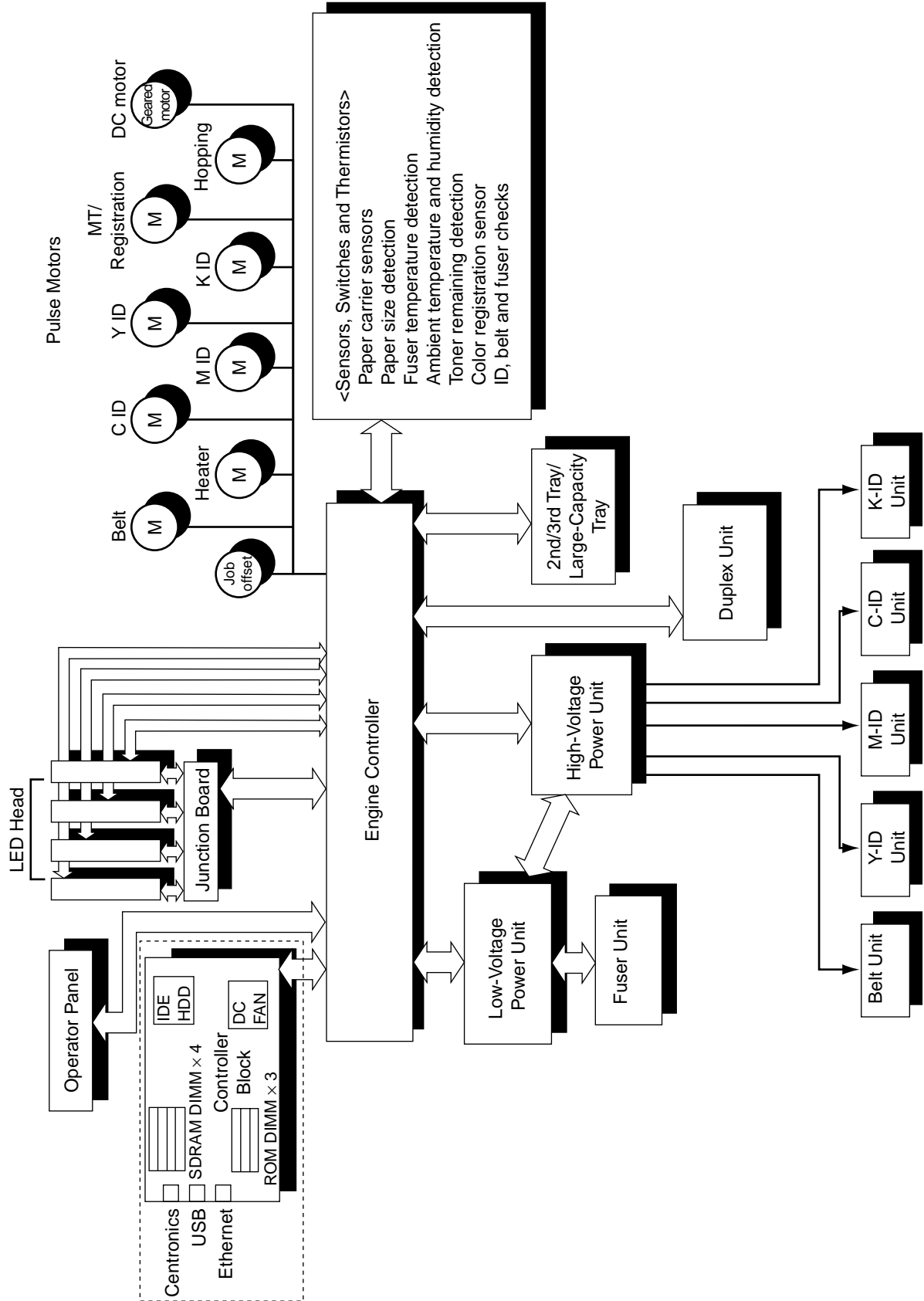

Figure 1.1

1.2 Printer Engine Specifications

The inside of the printer is composed of the followings:

- Electrophotographic Processor
- Paper Paths
- Controller Block (CU and PU)
- Operator Panel
- Power Units (High-Voltage Unit and Low-Voltage Unit)

Figure 1-2 shows the printer configuration.

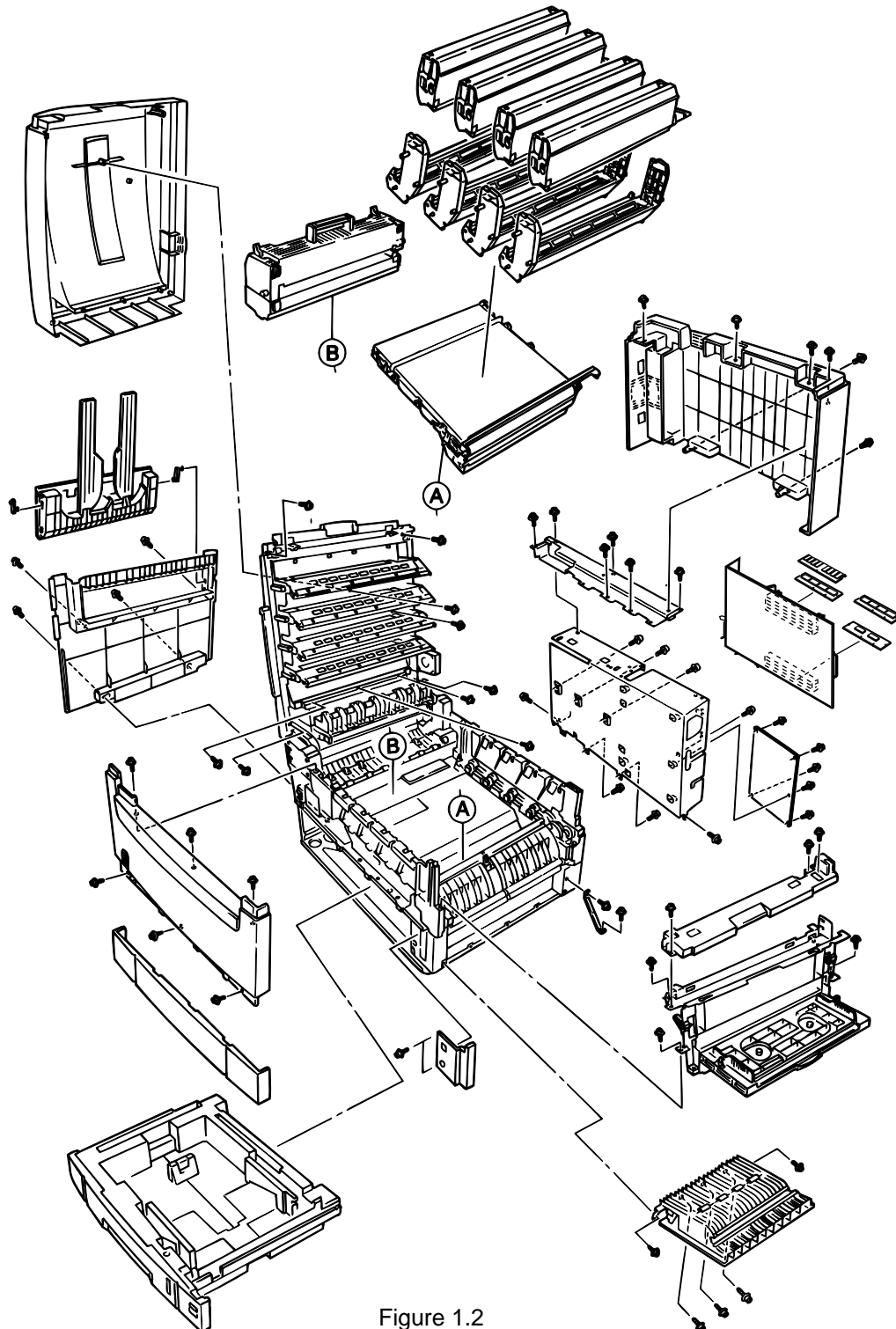
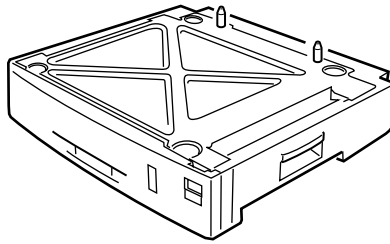

Figure 1.2

1.3 Option Configuration

The followings are available as options on C9000.

- (1) 2nd Tray/ 3rd Tray



- (2) Duplex Unit

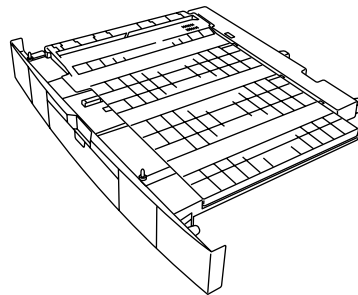

- (3) Large-Capacity Tray

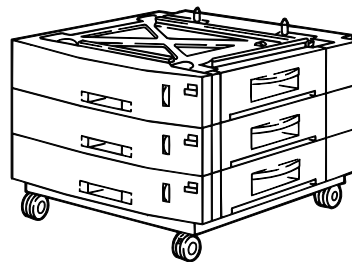

- (4) Expansion Memory 64/128/256MB

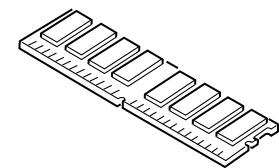
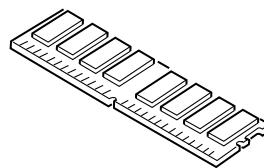
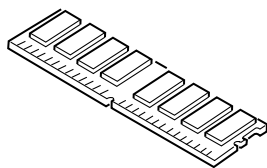

- (5) Internal Hard Disk

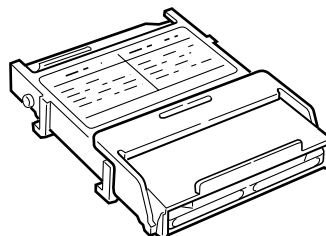

- (6) Ethernet Board

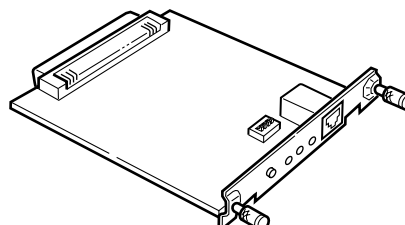

1.4 Specifications

- (1) Dimensions Height: 18.11 in. Width: 26.22 in. Length: 24.65 in.
- (2) Weight 158.7 lbs.
- (3) Paper Type: Ordinary paper and transparencies (Recommended: ML OHP01)
Size: Postal card, Legal 13" or 14", Executive, A4, A5, B5, A6, A3 A3-Nobi, B4
(Only the 1st tray and the front feeder support A6 and postal card sizes.)
Weight: 1st tray 55 kg to 90 kg (64 to 105g/m²)
Front feeder 55 kg to 140 kg (64 to 163g/ m²)
- (4) Print Speed Color: 21 pages per minute (Transparency: 5 pages per minute)
Monochrome: 26 pages per minute (Transparency: 15 pages per minute)
Postal Card, Label, Thick Paper: 10 pages per minute
- (5) Resolution 600 × 600 DPI / 600 x 1200 DPI (C9200 series) & 1200 x 1200 DPI (C9400 series)
- (6) Power Input 100VAC ±10%
- (7) Power Consumption Peak: 1400W Normal Operation: 550W (5% duty)
Idle: 150W Power Saving Mode: 50W
- (8) Frequency 50Hz or 60Hz ± 2%
- (9) Noise Operating: 54 dB (without Second tray)
Standby: 45 dB
Power Saving: 43 dB
- (10) Consumable Life Toner Cartridge: 15,000 pages (5% duty)
(in each of Y, M, C and K)
Image Drum: 39,000 pages (5% duty, Continuous printing)
(in each of Y, M, C and K)
- (11) Parts Replaced Periodically Fuser Unit Assy: Every 80,000 pages
Belt Cassette Assy: Equivalent of 80,000 pages (3P/J)
Transfer Belt cartridge: 60,000 prints

(12) Temperatures and Relative Humidities

Temperature

	Temperature (°F)	Temperature (°C)	Remark
Operating	50 to 89.6	10 to 32	17 to 27°C (Temperatures to assure full color print quality)
Non-Operating	32 to 109.4	0 to 43	Power-off
Storage (Max. One Year)	-14 to 109.4	-10 to 43	With drum and toner
Transport (Max. One Month)	-20 to 122	-29 to 50	With drum and without toner
Transport (Max. One Month)	-20 to 122	-29 to 50	With drum and toner

Humidity

	Relative Humidity (%)	Max. Wet-Bulb Temperature (°C)	Remark
Operating	20 to 80	25	50 to 70% (Humidities to assure full color print quality)
Non-Operating	10 to 90	26.8	Power-off
Storage	10 to 90	35	
Transport	10 to 90	40	

(13) Printer Life 1,000,000 pages (on a A4 basis) or five years

2. OPERATION DESCRIPTION

C9000, a tandem color electrophotographic page printer, adopts technologies such as 4992-LED array, OPC, dry single-component non-magnetic developing, roller transfer and heat-compression fusing. The printing method is black writing by shedding light on print areas.

Figure 2-1 provides the block diagram of this device.

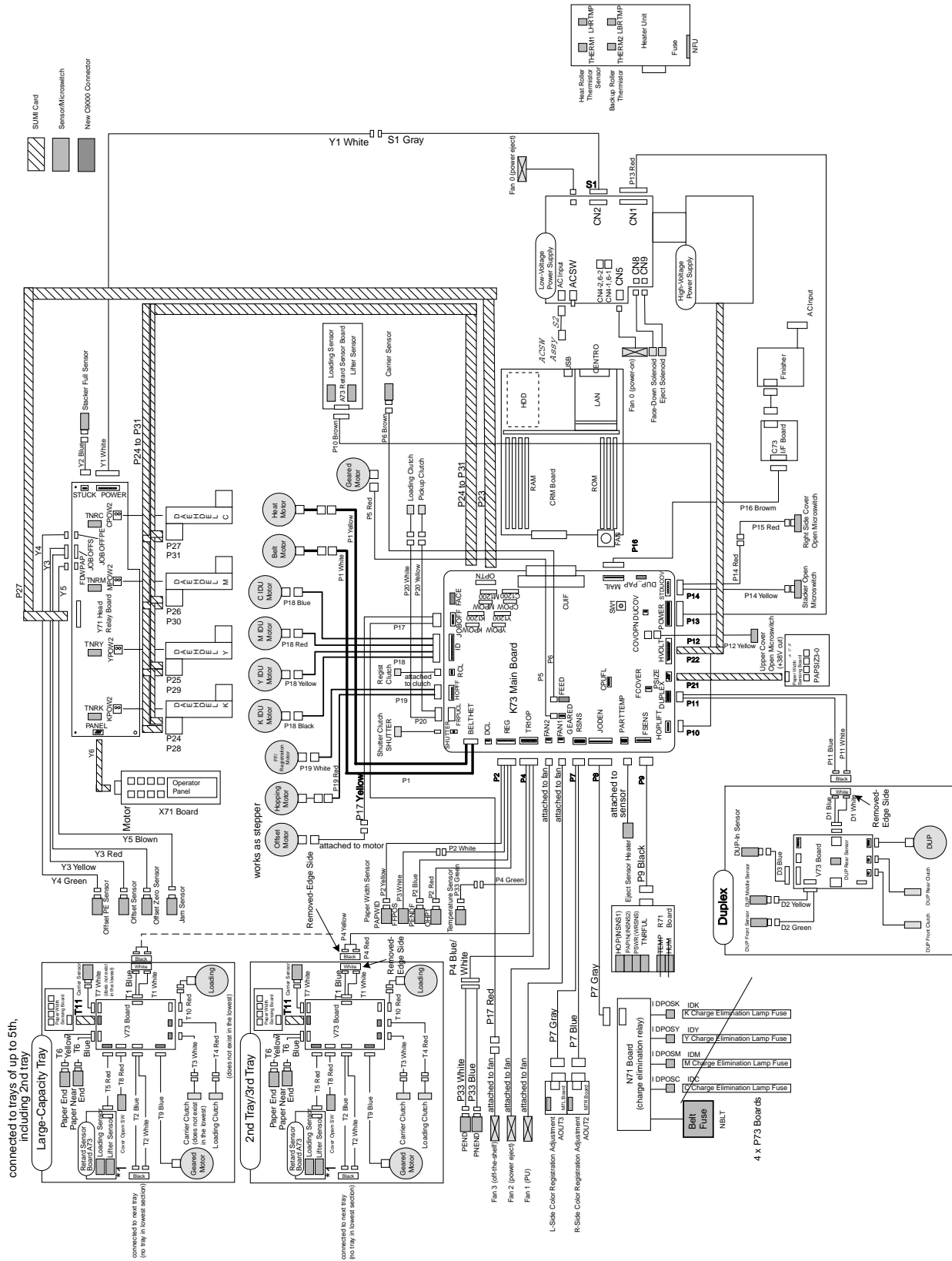

Figure 2.1

2.1 Main Control Board (CRM-PWB)

Figure 2-2 provides the block diagram of the main control board (CRM-PWB).

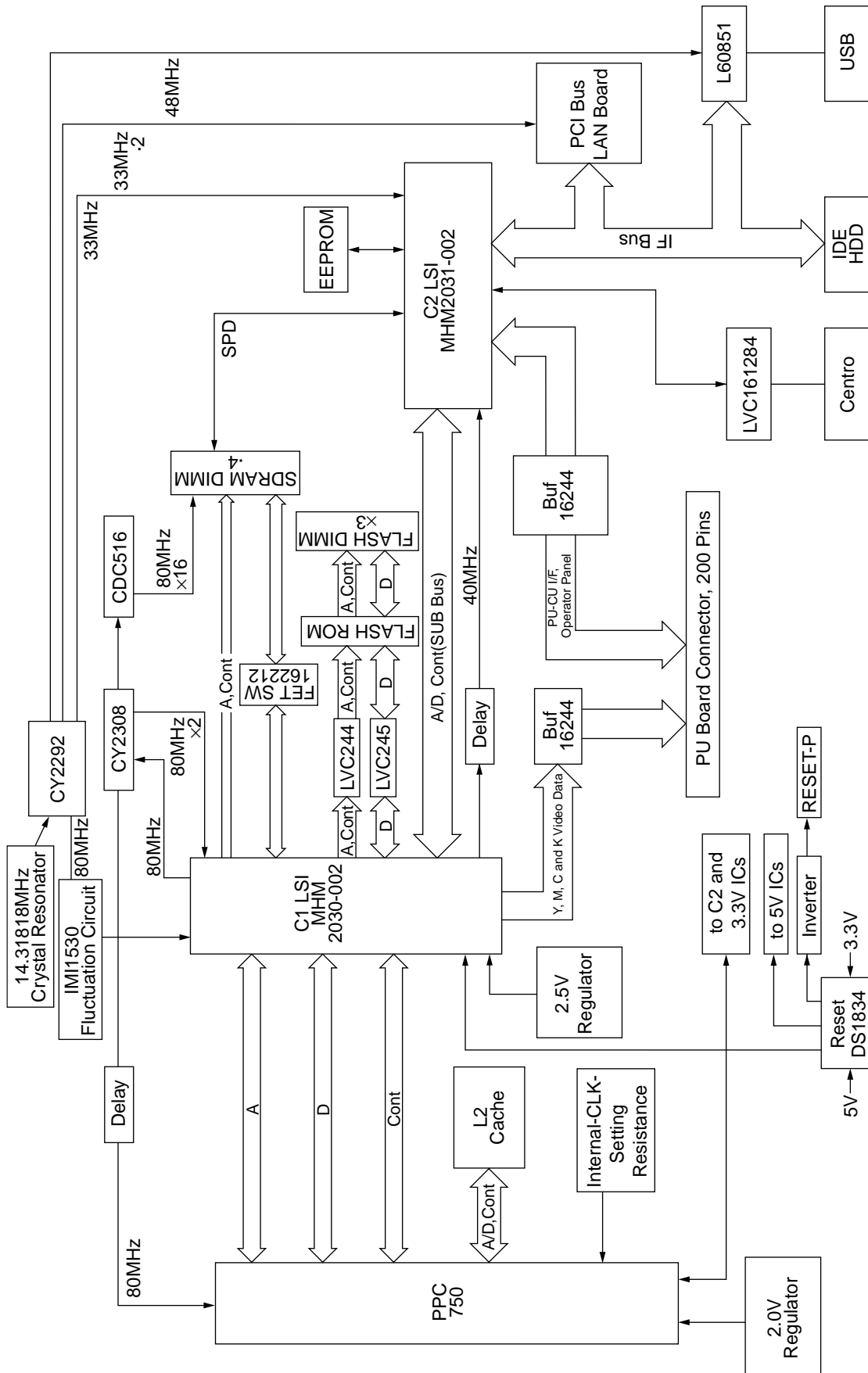

Figure 2.2

- (1) CPU
The CPU is 64-bit bus RISC processor PowerPC750, which receives an input of 80MHz (=BUS CLK) and operates at 400MHz, four-times the input.
- (2) Secondary Cache SRAM
SRAM is included as a secondary cache of the CPU on the board.
- (3) ROM
The ROM is inserted into the three 168-pin DIMM slots. The slot A is for a program ROM and the slot B is for the Japanese Kanji font. The slot C is not assigned.
- (4) RAM
The RAM is inserted into the four 168-pin DIMM slots. The DIMMs must be fitted in descending order of the type No. labeled on each of them into the slots 1, 3, 2 and 4.
SDRAM DIMM Specifications:
Speed: PC100 or more
Capacity: 64/128/256MB
Configuration: Without parity and ECC. Requires the SPD information. Number of chips contained = 8 or 16.
- (5) EEPROM
The EEPROM (16Kb), an 8-pin DIP package, is inserted into the IC socket supplying the 3.3V power. Settings for controlling the controller block are stored in the memory.
- (6) Flash ROM
A 2-megabyte flash ROM is surface-mounted on the CRM board. The flash ROM, composed of four chips of 256 kilo x 16 bits, can store fonts and macros.
- (7) Memory Control LSI (C1)
A 696-pin BGA package ASIC made by NEC, which is equipped with a cooling heat sink and mainly controls the CPU I/F, memory, video data compression and decompression, and PU-video I/F.
- (8) Interface Control LSI (C2)
A BGA package ASIC made by Toshiba, which controls the PU command I/F, operator panel I/F, IDE I/F, Centronics I/F, USB I/F, PCI I/F, EEPROM and SPD (SDRAM DIMM) I/F.
- (9) IDE HDD
An IDE connector is surface-mounted on the board to which an IDE HDD, assembled using molds for the purpose, is connected. The IDE HDD is used for storing font data, spooling edited video data temporarily and registering form data.
- (10) PCI Bus Option
Two PCI I/F slots are provided for option board use. The bus, which uses an Oki Data original connector, can accept an Ethernet board.
- (11) Host Interface
Standard: Centronics two-way parallel I/F (IEEE-1284-compliant)
USB (USB1.1-compliant)
Additional Board: (connected to PCI BUS)
Ethernet Board

2.2 Engine Control Board (K73 PWB)

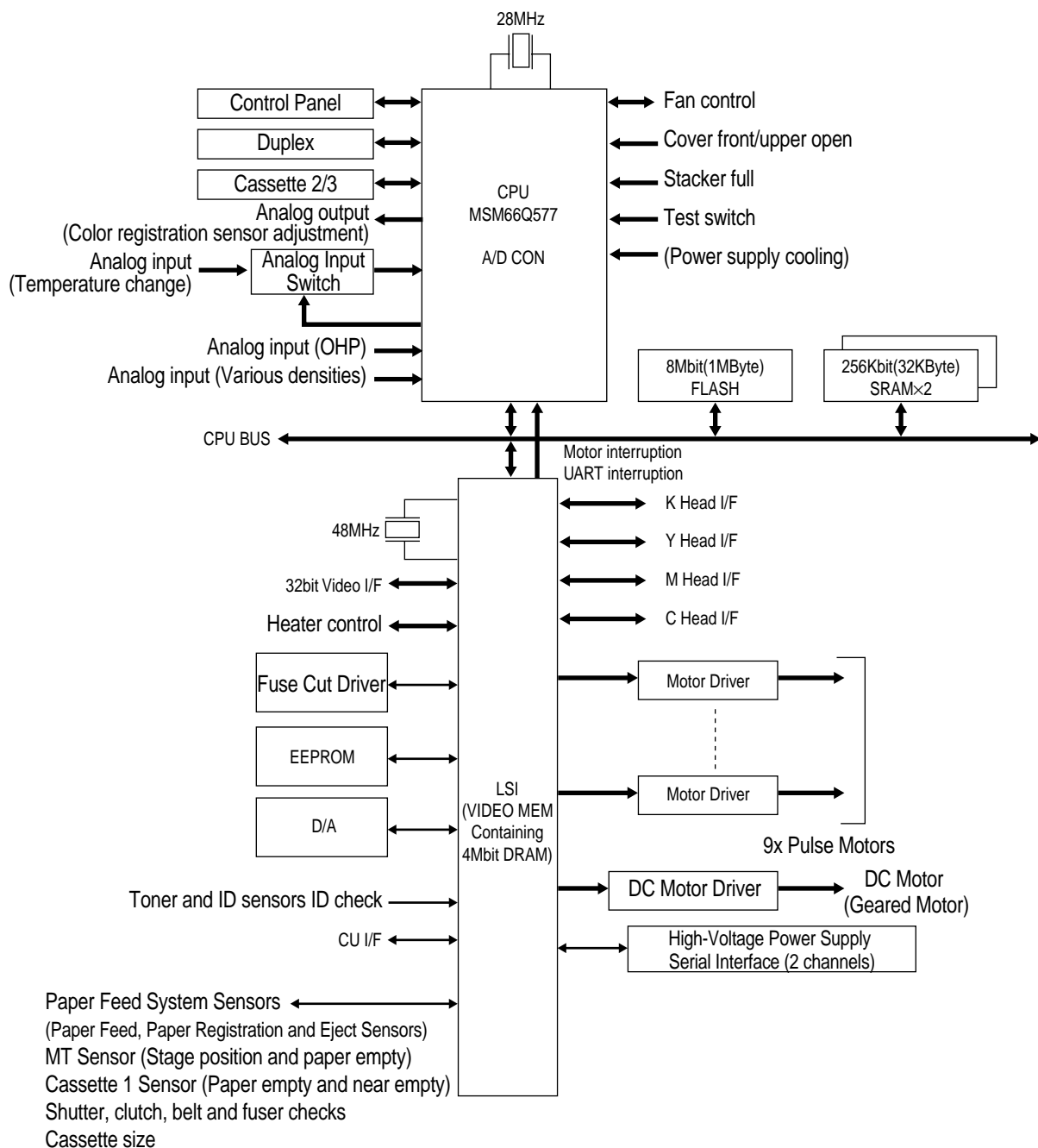

Figure 2.3

The engine control block (PU) is controlled by the engine control board (K73 PWB) which consists of a CPU (MSM66Q577), general LSI chip, flash ROM, EEPROM, pulse motor drivers, and video memory (see Figure 2.3).

- (1) CPU
This, a 16-bit CPU with an AD converter (OKI MIM66Q577), controls the entire system.
- (2) General LSI
This LSI (MG63P011-001LA), which is contained in the printer engine control block, incorporates 4 megabits of video memory and has functions such as engine-controller interfacing, LED interfacing, motor control, sensor input, video memory control, main scan color misalignment correction, skew correction and high-voltage power supply control.

- (3) Flash ROM
8 megabits of flash ROM (MBM29F800TA-70) which stores PU programs.
- (4) EEPROM
4 kilobits of EEPROM (NM93C66N-NW) which is mounted on the board with an IC socket and stores correction values.
- (5) Pulse Motor Driver
The pulse motor driver (A2918, A2919, A3955) drives nine pulse motors to revolve the EP and carry media.
- (6) SRAM
This SRAM (62256LFP-7LL) is used as working memory of the CPU.

2.3 Power Units

There is a low-voltage power unit, which consists of an AC filter circuit, low-voltage power circuit and heater driver circuit, and a high-voltage power unit which supplies a high-voltage power circuit.

(1) Low-Voltage Power Unit

This circuit generates the following voltages:

Output voltage	Use for
+3.3 V	Logic circuit power supply
+3.8V	Logic circuit power supply
+5 V	Motor and drive voltage for high-voltage power supply
+32 V	OP Amp, High-voltage power supply
+12 V	LED head

(2) High-Voltage Power Unit

This circuit generates the following 34V or more voltages, which are required for electrophotographic process, according to control sequences from the control board.

Output	Voltage	Use for	Remarks
CH	-900 to -1400±50V	Voltage to charging roller	
DB	Y, M, C: -10 to -400V/+300V	Voltage to developing roller	
K:	-10 to -400V/+300V		
SB	Y, M, C: -100 to -700/0V	Voltage to toner supplying roller	
TR	0 to 7KV	Voltage to transfer roller	Variable

2.4 Mechanical Processes

Figure 2.4 shows the mechanical processes of the printer.

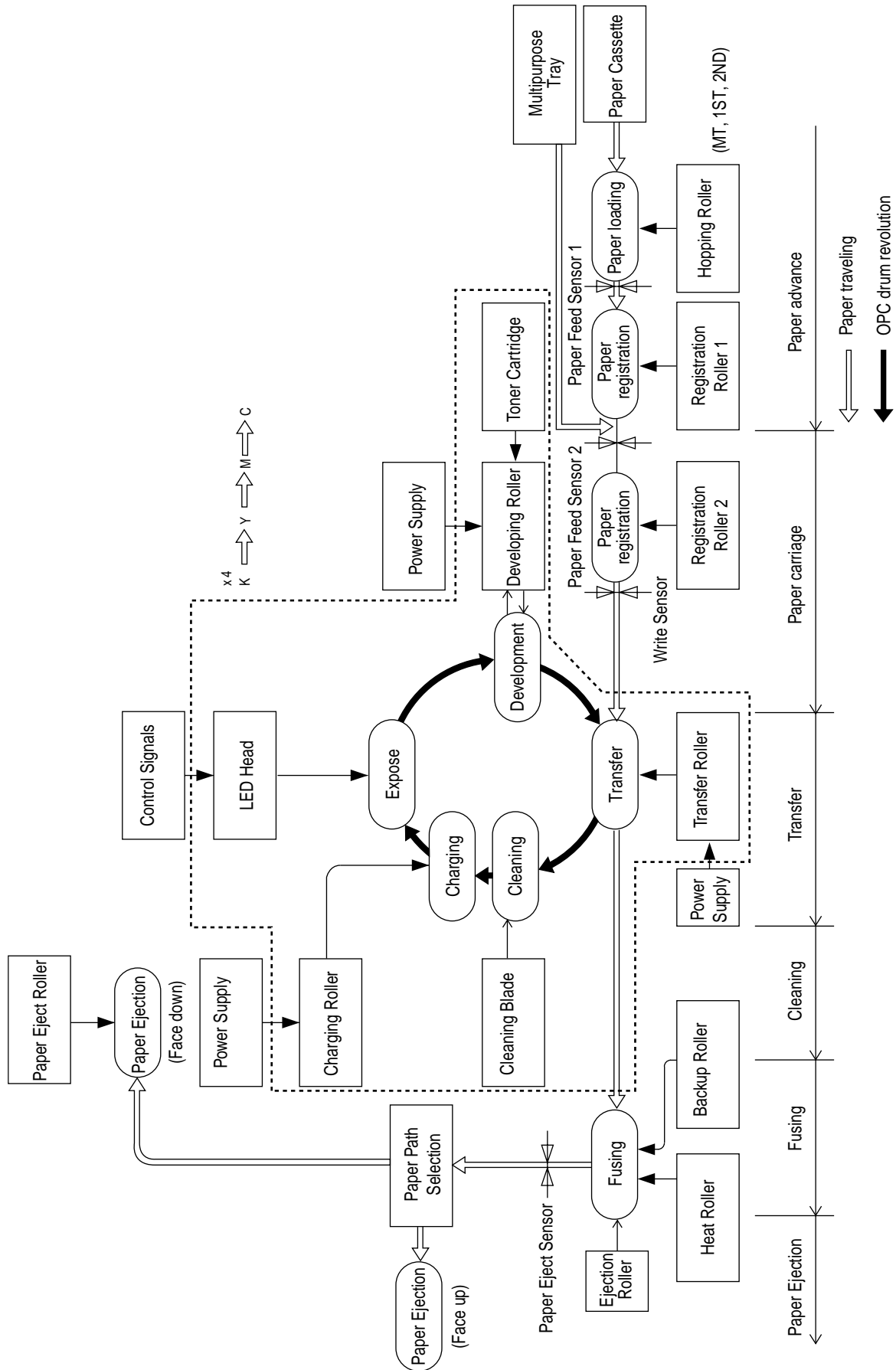

Figure 2.4

2.4.1 Electrophotographic process

(1) Electrophotographic process

The following is the outline of electrophotographic process:

① Charging

DC voltage is applied to the charging roller and the surface of the OPC drum is negatively and evenly charged.

② Exposure

The LED head, under image signals, emits light to the negatively charged surface of the OPC drum. The radiated portions of the drum surface attenuate in negative charge according to the intensity of the light and, based on the surface potentials, a latent electrostatic image is formed on the drum surface.

③ Development

Negatively charged toner contacts the OPC drum and, by electrostatic force, adheres to the latent electrostatic image to form a clear image on the drum surface.

④ Transfer

Paper is placed on the surface of the OPC drum, and positively, or opposite to the polarity of the toner, charged by the transfer roller on its back to transfer the toner image to the paper.

⑤ Cleaning

The cleaning blade removes residual toner from the OPC drum after the transfer.

⑥ Fusing

The toner image on the paper is fused into place through the application of heat and pressure to it.

- (2) Charging
Negative DC voltage is applied to the charging roller contacting the surface of the OPC drum.

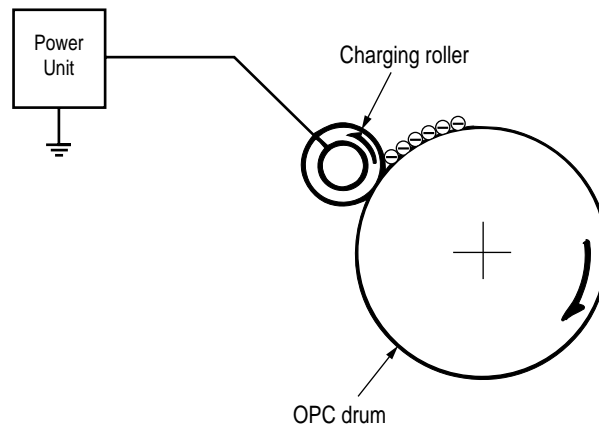

- (3) Exposure
The negatively charged surface of the OPC drum is radiated with light from the LED head. The negative charge of the radiated portions of the drum surface attenuates in response to the intensity of the light and a latent electrostatic image responsive to the potentials of the surface is formed on the drum surface.

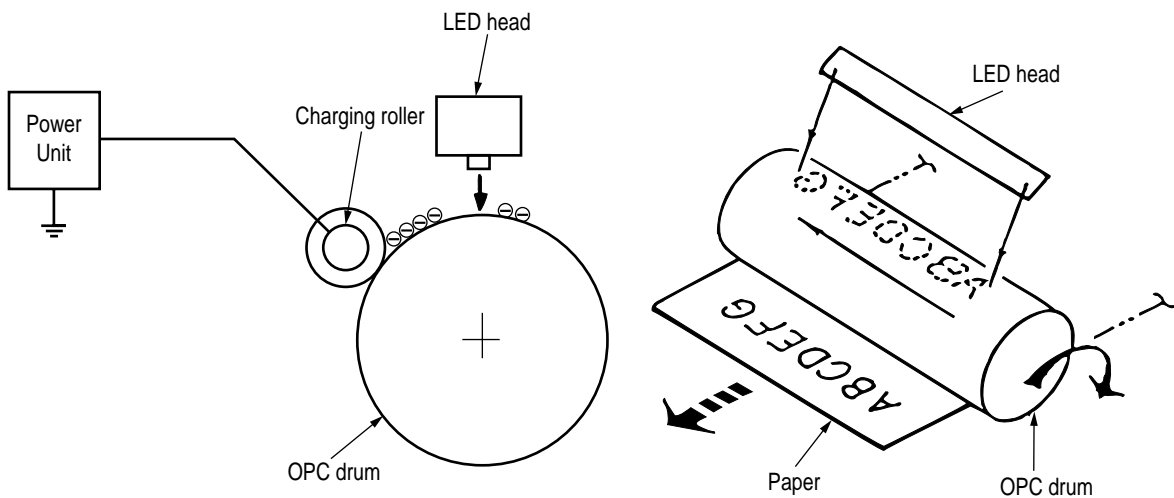

(4) Developing

By the adhesion of toner to the latent electrostatic image on the drum surface, the image is changed to a toner image. The developing is processed at the contact part between the OPC drum and the developing roller.

- ① The sponge roller causes toner to adhere to the developing roller. The toner becomes negatively charged.

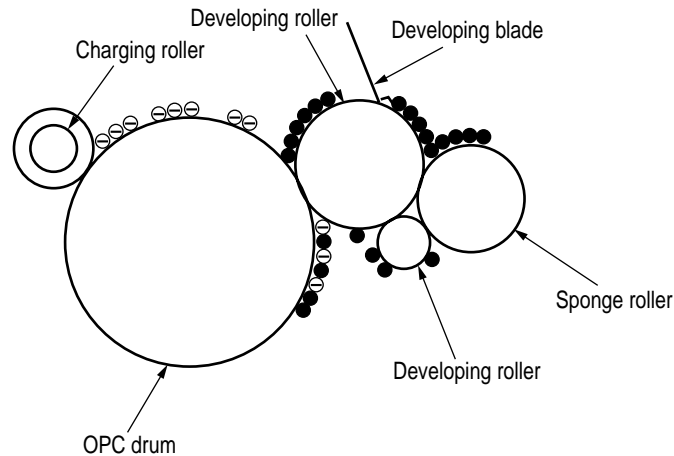

- ② The developing blade removes excess toner from the developing roller and a thin layer of remaining toner is formed on the developing roller.
- ③ The toner is drawn by the latent electrostatic image at the contact portion between the OPC drum and the developing roller. The latent electrostatic image on the drum surface is made visible with the toner.

(5) Transferring

The transfer roller, which is made of conductive sponge, presses paper against the surface of the OPC drum and brings the paper into intimate contact with the drum surface. The paper is placed on the drum surface and positively (opposite to the charge of the toner) charged by the transfer roller on its back.

Applying positive high voltage from the power supply to the transfer roller moves the positive charge induced by the transfer roller to the paper surface at the contact portion between the transfer roller and the paper, the paper surface drawing the negatively charged toner from the drum surface.

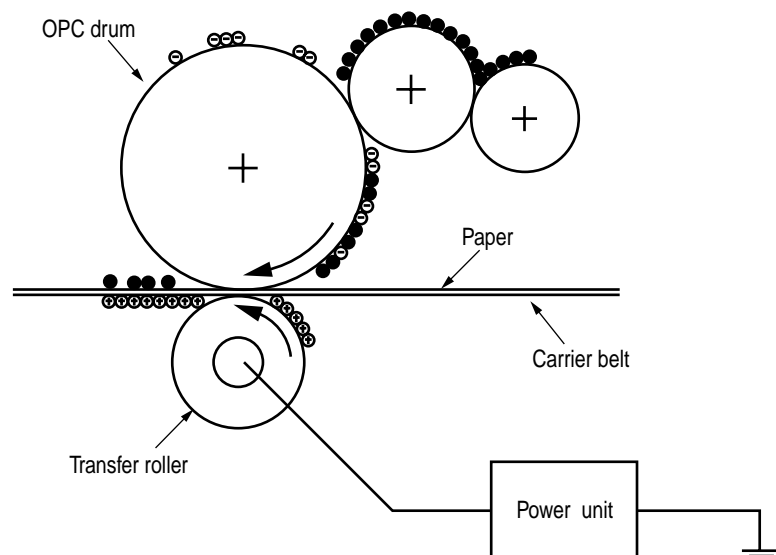

(6) Fusing

When passed between the heat roller and the backup roller, the toner image transferred to the paper is fused into place by the application of heat and pressure to it.

The Teflon coated heat roller is heated by the built-in heat roller of 800W/backup roller of 500W (halogen lamp). The fusing temperature is controlled by the sum of the temperature detected by the thermistor moving over the surface of the heat roller and the temperature detected by the thermistor moving over the surface of the backup roller. A thermostat, which is provided for safety, becomes open by a heat roller temperature rise of not less than fixed degrees and cuts off voltage supply to the heater. The backup roller is being pressed against the heater by the pressure springs on both sides.

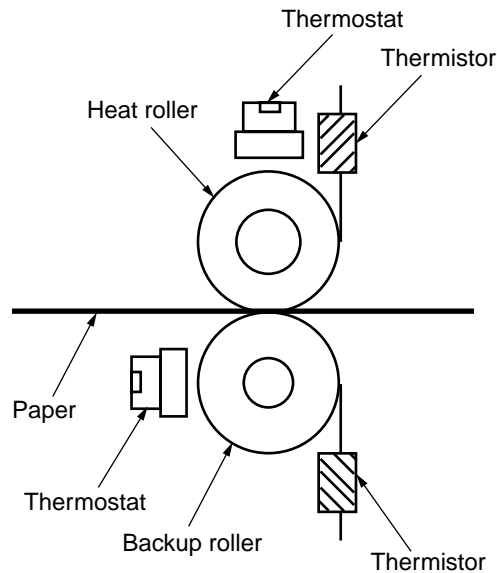

(7) Cleaning

Non-fused, residual toner on the OPC drum is scraped with the cleaning blade and collected in the waste toner area of the toner cartridge.

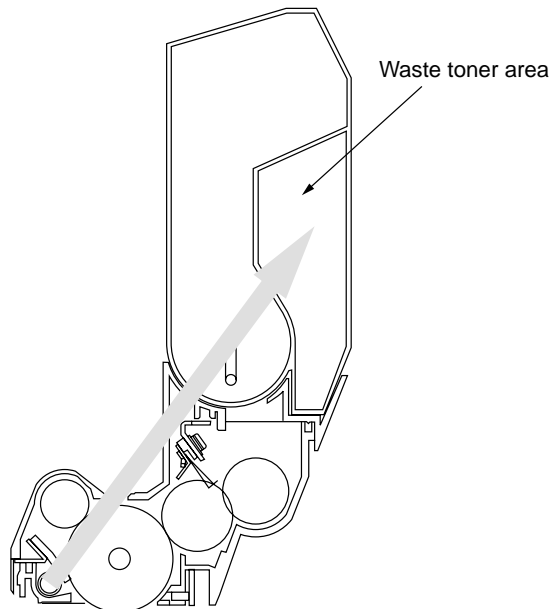

(8) Cleaning

Residual toner on the transfer belt is scraped with the cleaning blade and collected in the waste toner box of the transfer belt unit.

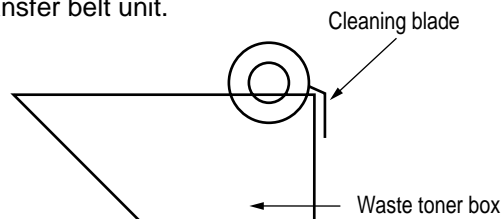

2.4.2 Paper running process

Figure 2.5 shows how paper moves in the C9000.

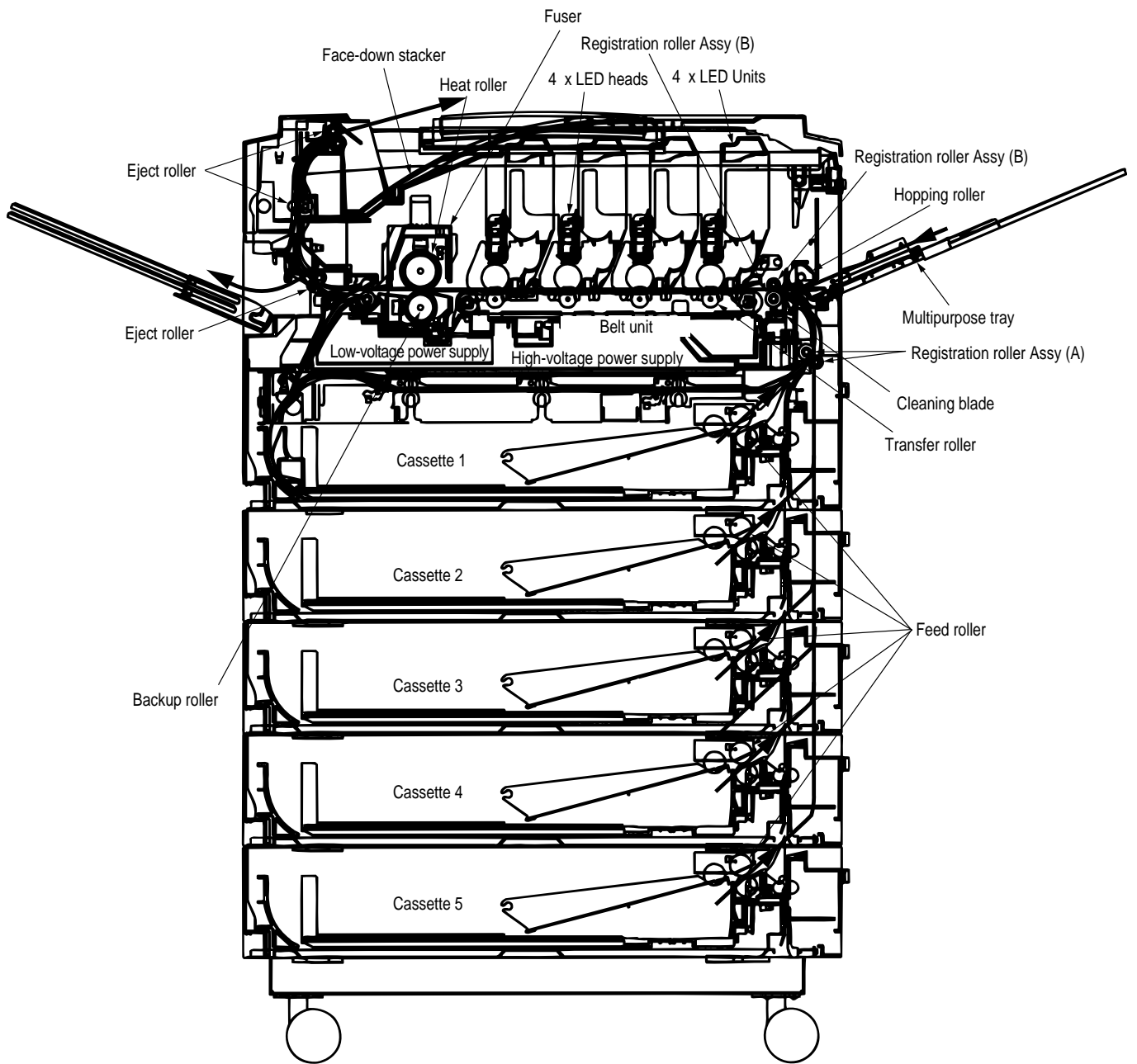

Figure 2.5 Paper Route

(1) Paper Loading from 1st Tray

1. The paper loading motor runs (CCW), the paper loading clutch is engaged and, until the entrance cassette sensor is turned on, paper is advanced (the on/off operations of the paper loading clutch control the pickup roller).
2. After the paper turns the entrance cassette sensor on, the paper is forwarded a further fixed length and touches the registration roller Assy (A) (this corrects paper skew).
3. The electromagnetic clutch is engaged and the paper is carried onto the carrier belt.

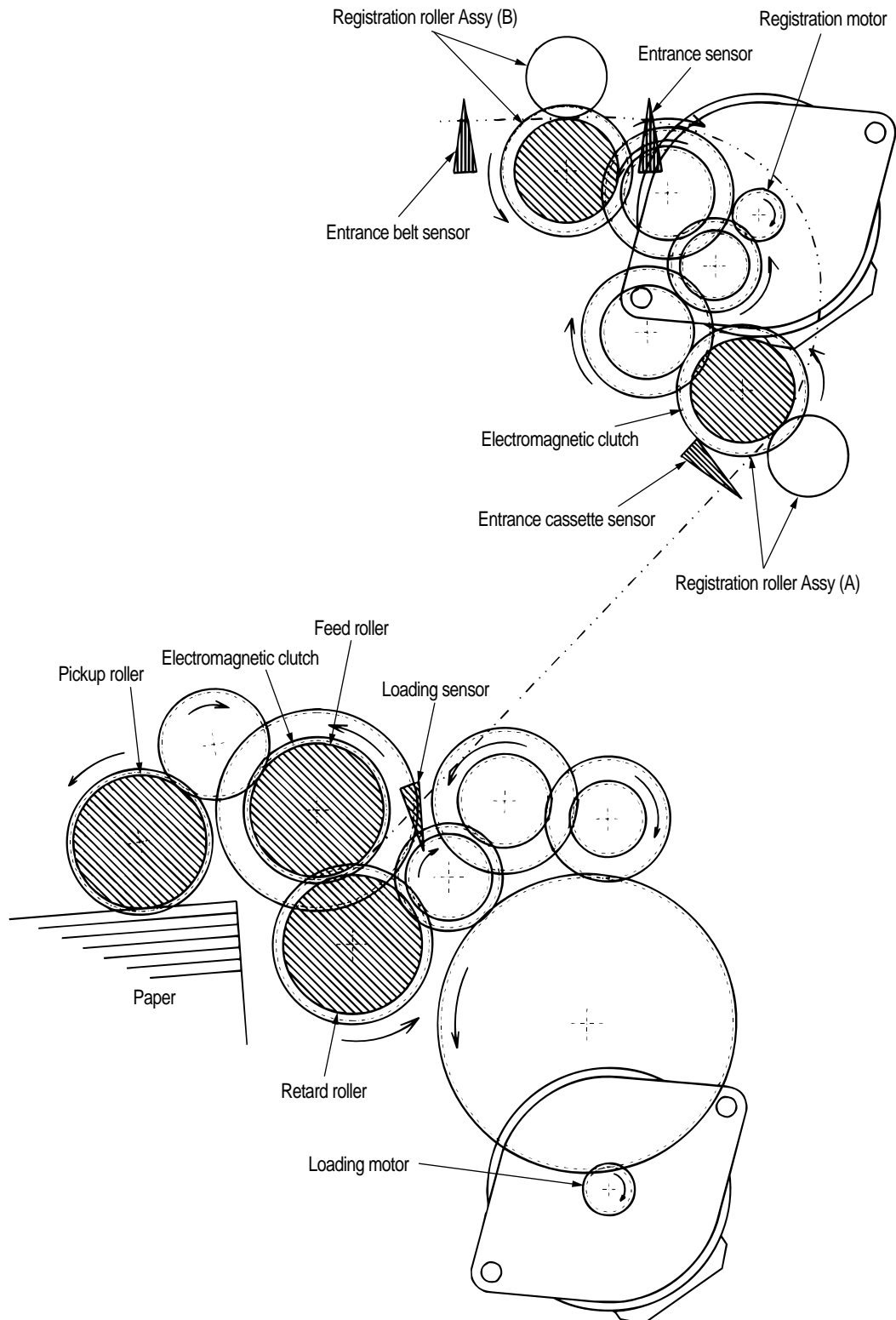

Figure 2.6

(2) Paper Loading from Option Tray

1. The paper loading motor runs (CW), the paper loading clutch is engaged and, until the carrier sensor on a tray which sits atop a loading tray is turned on, paper is advanced.
2. After the paper turns the carrier sensor on, the paper is forwarded a further fixed length and touches the carrier roller (this corrects paper skew).
3. The carrier clutch is thrown in and the paper is fed into the main body.

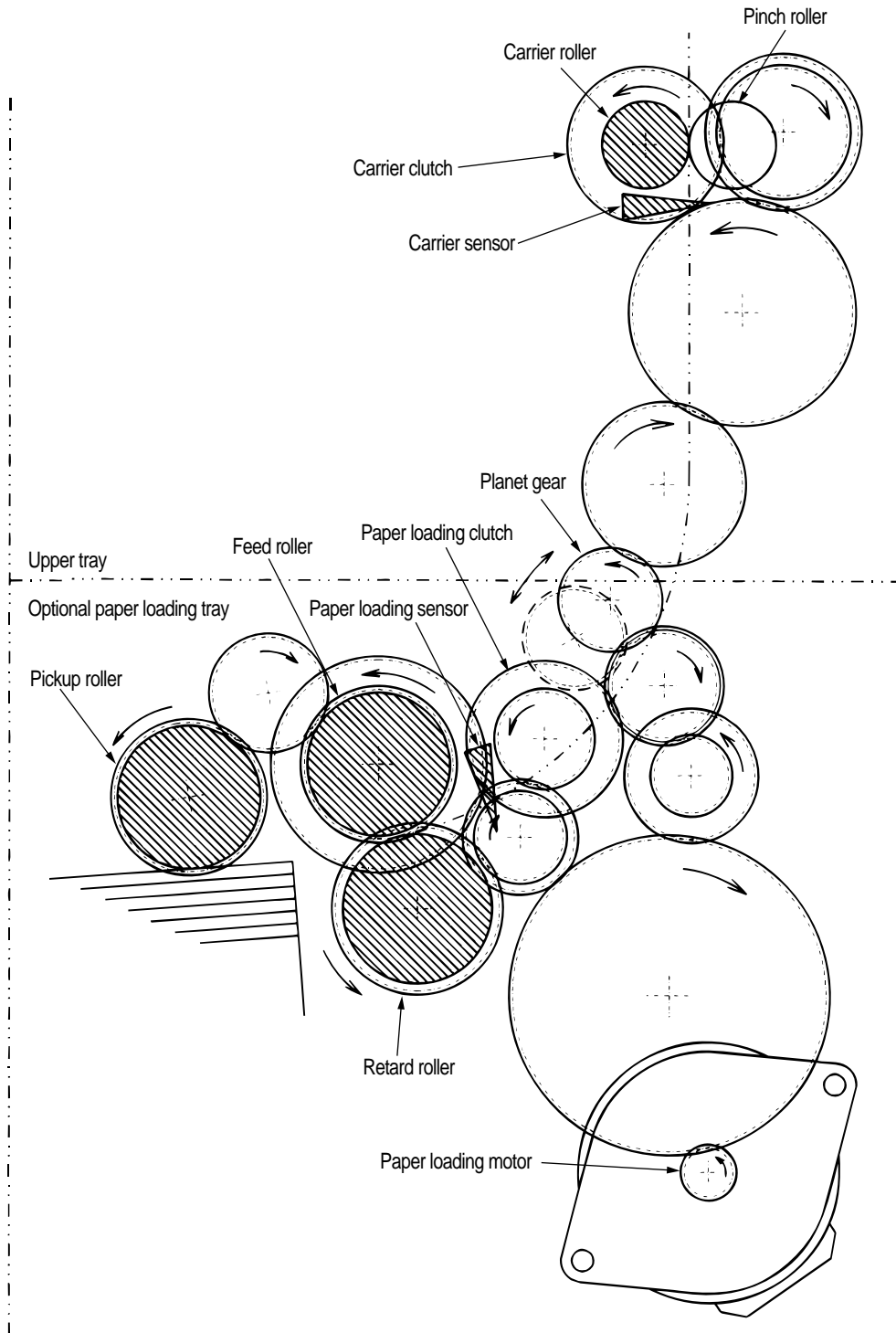

Figure 2.7

(3) Paper Loading from Multipurpose Tray (MT)

1. The release lever usually pushes down the hopping plate to a position to turn the micro SW on (Figure 2.8-a).
2. The running of the motor in the (a) direction drives the MT feed roller, causing the cam to turn. The cam pushes the release lever and the hopping plate picks up paper sent out by the MT feed roller (Figure 2.8-b), where the registration roller Assy (B) does not move as its one-way clutch gear (1) idles.
3. After the front edge of the paper turns the entrance sensor on, the paper is forwarded a fixed length. The paper stops when its front edge reaches the registration roller Assy (B).
4. Concurrently, the cam pushes down the hopping plate. The release lever that has been placed in its original position by the spring locks the hopping plate (Figure 2.8-c).
5. After the completion of the paper feed operation, the registration motor runs in the direction of the arrow (b) to drive the registration roller Assy (B), where the one-way clutch gear does not allow the MT feed roller to move.

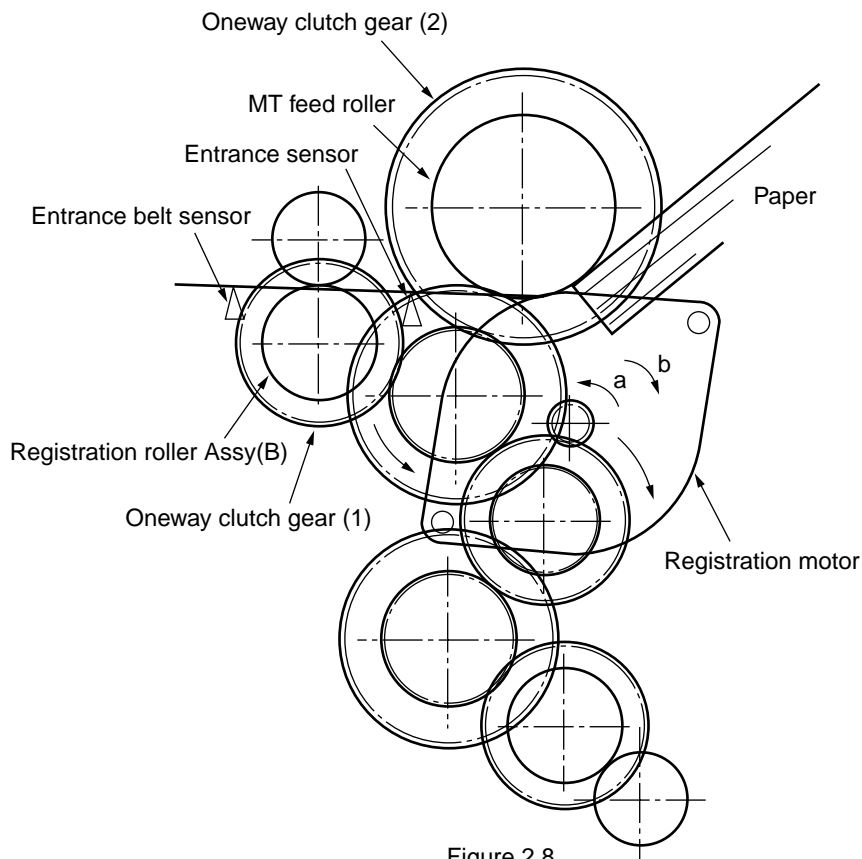
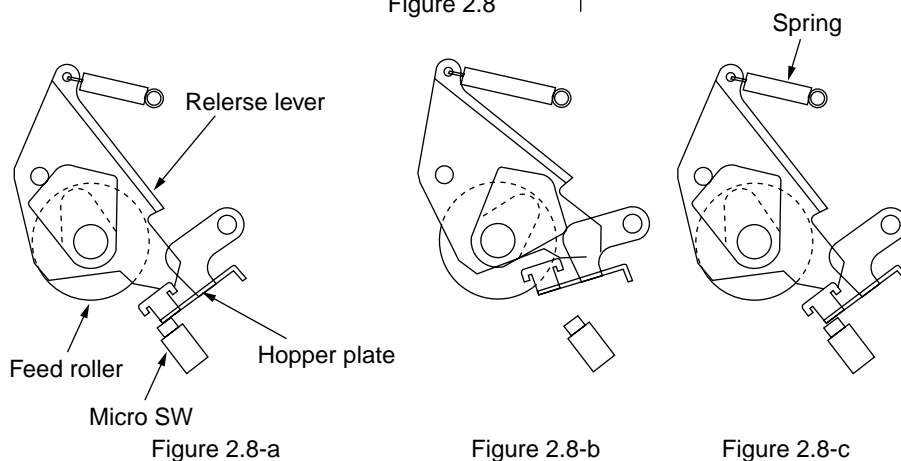

Figure 2.8



(4) Carrier Belt

1. The running of the carrier belt motor in the direction of the arrow (a) drives the carrier belt. The belt unit sits with one carrier roller immediately below each color's drum, and the carrier belt between them. By the application of a fixed voltage, the carrier belt and carrier roller feed paper on the carrier belt into the fuser unit, transferring a toner image from each color's drum.

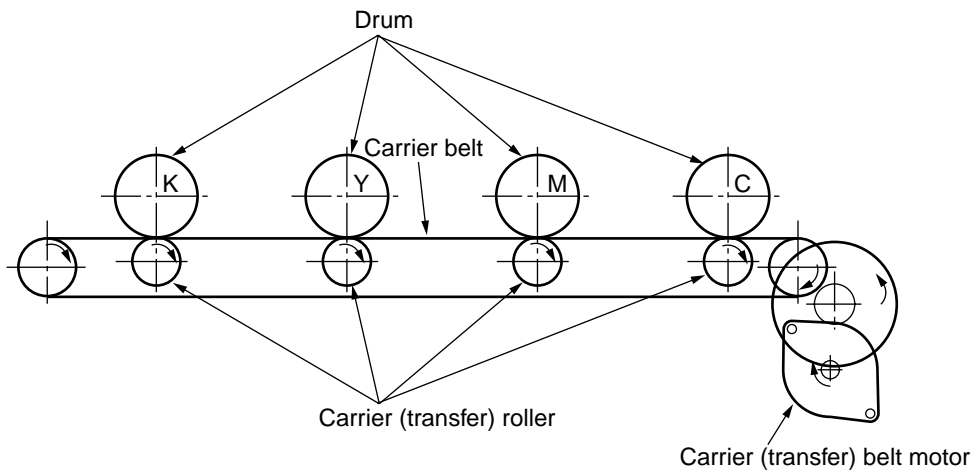

Figure 2.9

(5) Driving and Up-and-Down Movements of I/D Unit

1. The I/D unit driving and up-and-down movements are effected by a single-pulse motor. The running of the main motor in the direction of the arrow (a) turns the lever 1 to the left. Then, the lever 2 that was lifted by the lever 1 lowers to move down the I/D unit. After the up-and-down sensor is turned on (Figure 2.10-c), the specified downward pulsing places the I/D unit in its lowest position (or equivalently, printing position). The drum gear engages with the driving gear and starts revolving to transfer an image on the drum to running paper, where the one-way gear idles upon placement of the lever in its lowest position.
2. With the running of the main motor in the direction of the arrow (b), the lever 1 pushes up the I/D unit via the lever 2. After the up-and-down sensor is activated (Figure 2.10-d), the lever 1 lifts the I/D unit to a specified level and stops to keep space to an extent between the drum and the carrier belt (Figures 2.10-c and 2.10-e). The drum gear is not engaged with the driving gear and does not revolve.
3. When the two pins of the up-and-down sensor are pushed up by the I/D unit, and touches and electrically connected to the plate above the pins, the sensor recognizes the on state. When the two pins are pushed down by the I/D unit, and separated and insulated from the plate, the sensor recognizes the off state. The installation of the I/D unit can also be verified by recognizing the off state of the up-and-down sensor.

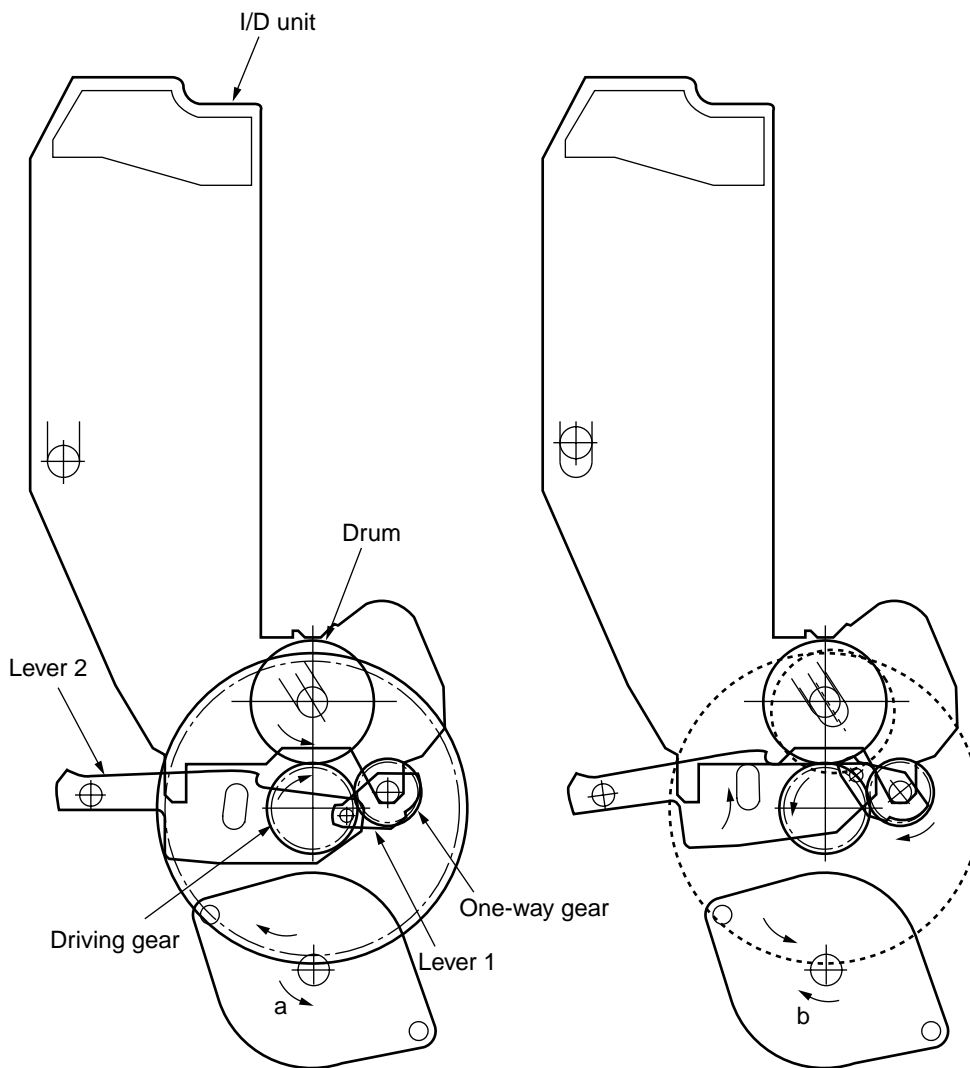

Figure 2.10-a

Figure 2.10-b

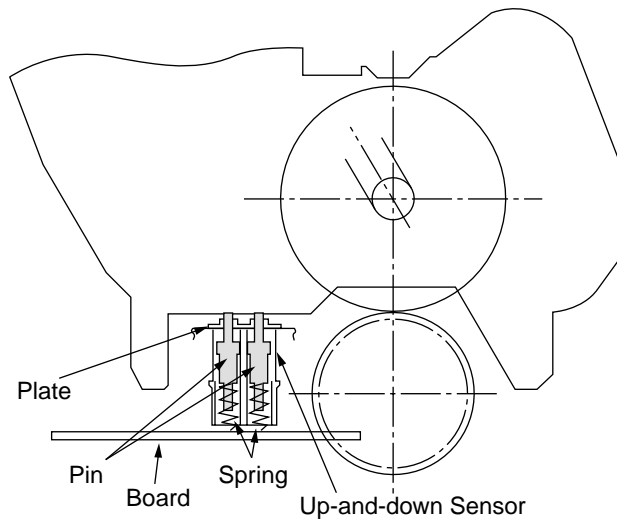

Figure 2.10-c

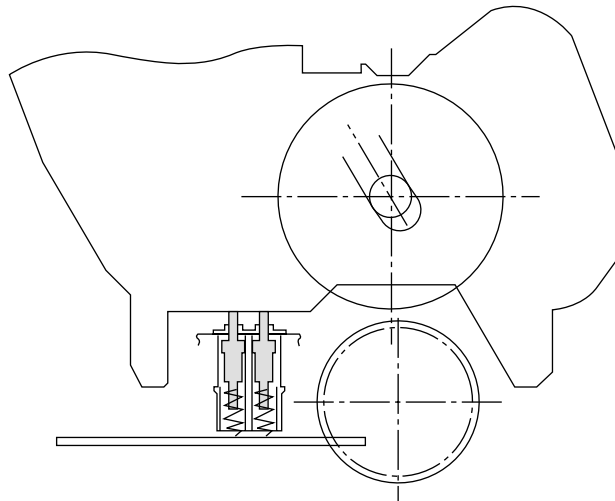

Figure 2.10-d

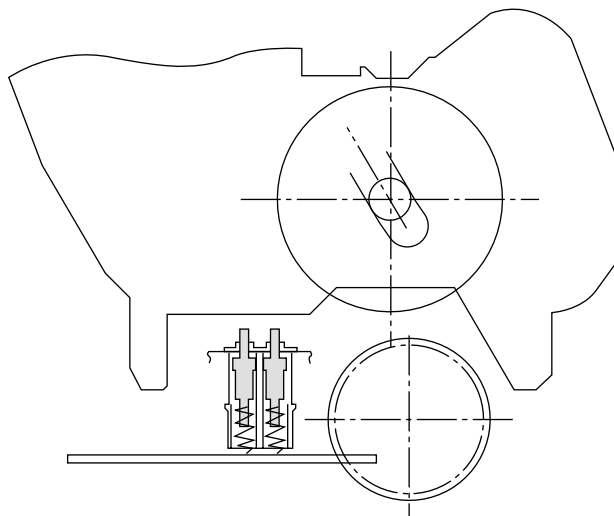

Figure 2.10-e

(6) Fuser Unit and Paper Ejection

1. A single-pulse motor drives the fuser unit and the eject rollers.
In response to the running of the heat motor in the direction of the arrow (a), the heat roller turns. This roller fuses a toner image to paper by heat and pressure.
2. At the same time, the four eject rollers move to eject the paper.
3. The paper separator solenoid switches the path back and forth between the route to the face-up stacker and the route to face-down stacker.

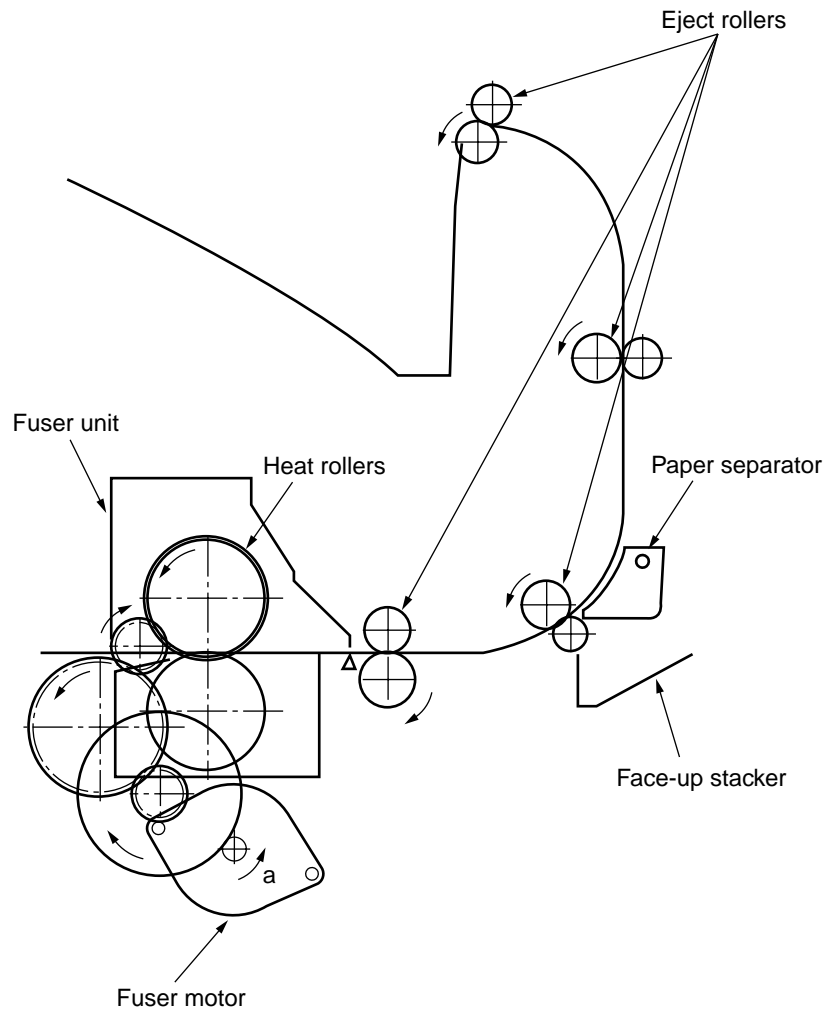

Figure 2.11

(7) Duplex Unit

1. When the duplex unit receives an instruction from the printer to print on both sides of a sheet of paper, the solenoid opens the separator after the completion of one side printing of a sheet of paper sent from the tray. The path is switched to that to the duplex unit. At this time, as the roller (1) turns in the direction of the arrow "a," the paper is retracted on the rear of the cassette.
2. When fixed time has elapsed after the front edge of the paper passes through the duplex-in sensor, the rollers reverse and the roller (1) turns in the direction of the arrow "b" to feed the paper into the duplex unit. After that, the paper passes through the rollers (2), (3) and (4), and ejected with the other side printed, and fed again into the printer.

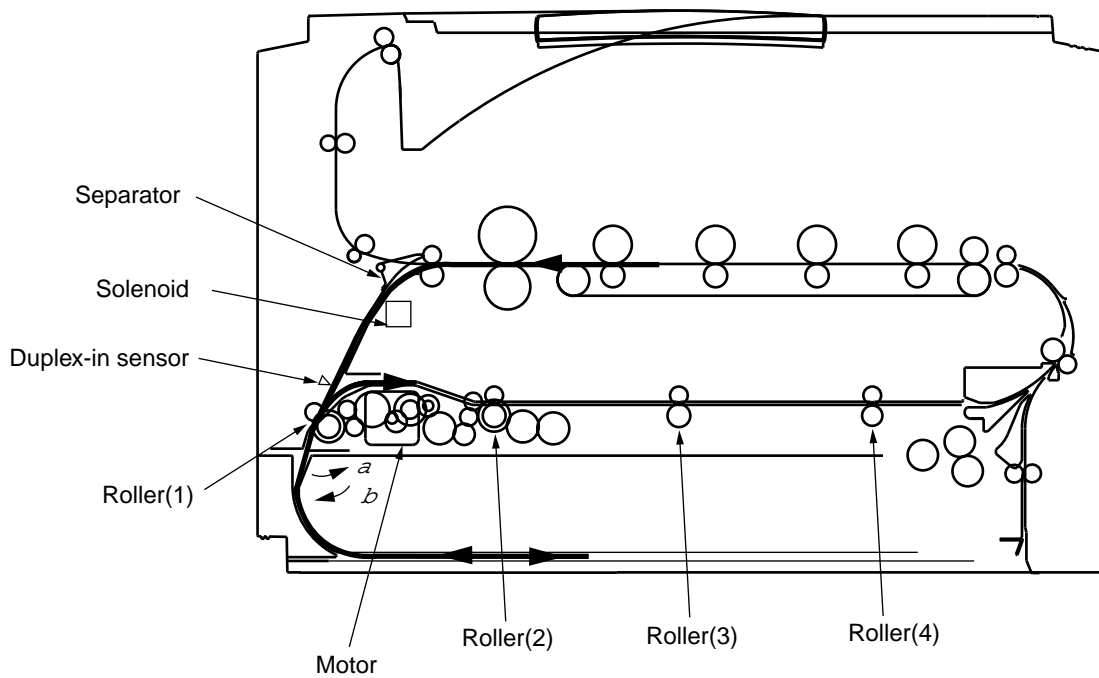
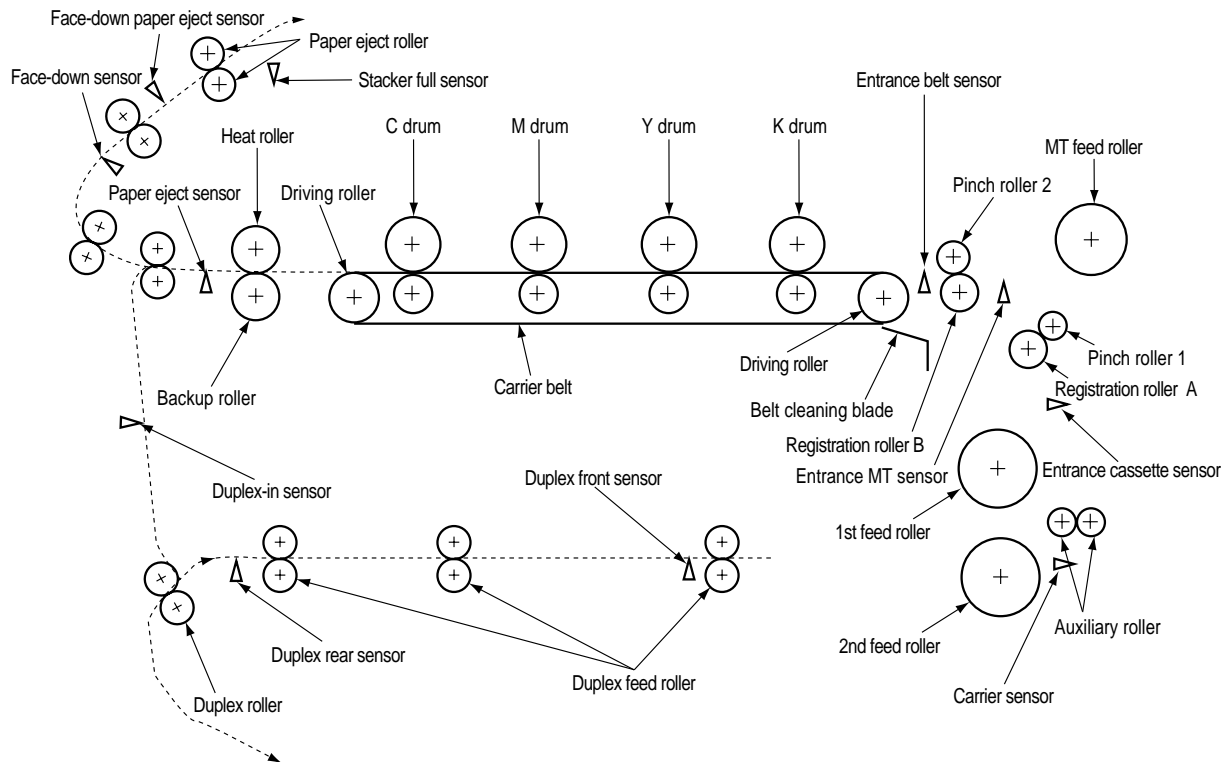

Figure 2.12

2.5 Sensor

2.5.1 Paper related sensors



Sensor	Function	Sensor status
Entrance MT Sensor Entrance Cassette sensor	Detects the beginning of incoming paper to determine the timing for switching from hopping to carriage.	ON : Paper exists. OFF: Paper is empty.
Entrance Belt sensor	Detects the beginning of transferred paper and, based on the time taken until the paper front edge reaches the sensor, determines the paper length.	ON : Paper exists. OFF: Paper is empty.
Paper Eject sensor	Detects the beginning and end of paper to determine the paper ejection timing.	ON : Paper exists. OFF: Paper is empty.
Duplex-In sensor	Detects the beginning of paper which enters into the duplex unit to determine the time taken until the reversed rollers turn in forward direction.	ON : Paper exists. OFF: Paper is empty.
Duplex Rear sensor	Detects the beginning of paper after the turns in reverse direction, in the duplex unit.	ON : Paper exists. OFF: Paper is empty.
Duplex Front sensor	Detects the end of paper after the turns in reverse direction to determine the paper ejection timing, in the duplex unit.	ON : Paper exists. OFF: Paper is empty.
Stacker Full sensor	Detects the face-down stacker full of paper.	ON : Stacker is full. OFF: Stacker is empty.
Face-Down Paper Eject sensor	Detects paper carriage to the paper eject roller to determine the timing for job offset operation.	ON : Stacker is full. OFF: Stacker is empty.
Face-Down Route sensor	Detects the face-down carrier route jammed with paper when it has a paper jam.	ON : Stacker is full. OFF: Stacker is empty.
Carrier sensor	Detects paper carriage from the option tray.	ON : Stacker is full. OFF: Stacker is empty.

2.5.2 Other sensors

- ① Paper Empty sensor
This sensor checks whether the paper cassette is empty.
- ② Paper Near sensor
This sensor checks whether the paper cassette is near empty.
- ③ MPF Paper Empty sensor
This sensor checks whether the front feeder has paper.
- ④ MPF Hopping switch
This microswitch checks whether the front feeder table is in the up position or in the down position.
- ⑤ Stacker Full sensor
This sensor checks whether the stacker is full.
- ⑥ Paper Size switch
This sensor detects the size of paper in the paper cassette.
- ⑦ EP Up/Down sensor (one for each of colors, Y, M, C and K)
This sensor checks whether the I/D unit is in the up position or in the down position.
- ⑧ Toner K, Y, M and C sensors
By measuring the time interval between regular opening movements of each sensor's lever, the sensor checks whether its toner cartridge is empty.
- ⑨ Temperature sensor
See Section 2.6 (Transfer Control Responds to Environmental Changes)
- ⑩ Humidity sensor
See Section 2.6 (Transfer Control Responds to Environmental Changes)
- ⑪ OHP sensor
This sensor detects the presence or the absence of transparencies.
- ⑫ Alignment sensor
When color misalignment has been corrected, this sensor reads the alignment pattern printed at the right and left ends of the transfer belt (see Section 2.13).

2.6 Color Misalignment Correction

C9000 is equipped with multiple LED heads, which can result in color misalignment. The mechanically induced color misalignment is automatically corrected as follows:

- (1) Color alignment to be corrected
 - ① Color misalignment in X-axis direction (Positional error caused by LED head)
 - ② Color misalignment in slanting direction (Positional error caused by LED head)
 - ③ Color misalignment in Y-axis direction (Positional error caused by I/D unit and LED head)
- (2) Correcting
Printing the preset color misalignment detection pattern on the belt and, by a reflection sensor, reading the printed pattern detects each color's misalignment value to determine its correction value. The correction value is used to change each color's (Cyan, Magenta and Yellow) writing timing in comparison with that of Black.

2.7 Transfer Control Responds to Environmental Changes (Room Temperatures and Relative Humidities)

C9000 measures room temperature and relative humidity using a room temperature sensor and humidity sensor, and calculates an optimum transfer voltage under its measurement environment to perform real-time control on printing with the optimum voltage.

2.8 Paper Jam Detection

C9000 detects paper jams after power-on and during printing. When a paper jam occurs, the printer immediately suspends the printing operation. Opening the cover to remove the jammed paper and closing it resumes the printing.

LCD Error Code	Error	Description
400	Paper Size Error	The entrance cassette sensor does not turn off within fixed time after it turns on. Loading of plural sheets of paper is sensed.
372	Misfeed from Duplex Carrier Assembly	Paper could not be loaded from the duplex carrier assembly.
390	Misfeed from Multipurpose Tray (MT)	Paper could not be loaded from the MT (the entrance MT sensor does not turn on within fixed time after the hopping).
5-395 4-394 3-393 2-392 1-391	Misfeed from Cassette 1, 2, 3, 4 or 5	Paper could not be loaded from the cassette 1, 2, 3, 4 or 5 (the entrance cassette sensor does not turn on within fixed time after the hopping).
370	Duplex Paper Jam in Reversing	The duplex rear sensor does not turn on during the paper reversing operation of the duplex unit.
383	Duplex Unit Entrance Paper Jam	The duplex-in sensor does not turn on during the paper loading in the duplex unit.
371	Duplex Unit Input Paper Jam	The duplex front sensor does not turn on during the operation.
382	Paper Ejection Jam	The paper eject sensor does not detect the end of paper within fixed time after sensing the beginning of it. The paper eject sensor does not turn off after it turns on.
381	Paper Carriage Jam	The paper eject sensor does not turn on while paper is running on the belt.
380	Loading Jam	Paper does not reach the entrance belt sensor or the MT sensor after the completion of the hopping.
490	MT Paper Empty	Printing occurs with no paper in the MT.
5-495 4-494 3-493 2-492 1-491	Cassette 1, 2, 3, 4 or 5 Paper Empty	The cassette 1, 2, 3, 4 or 5 has no paper.

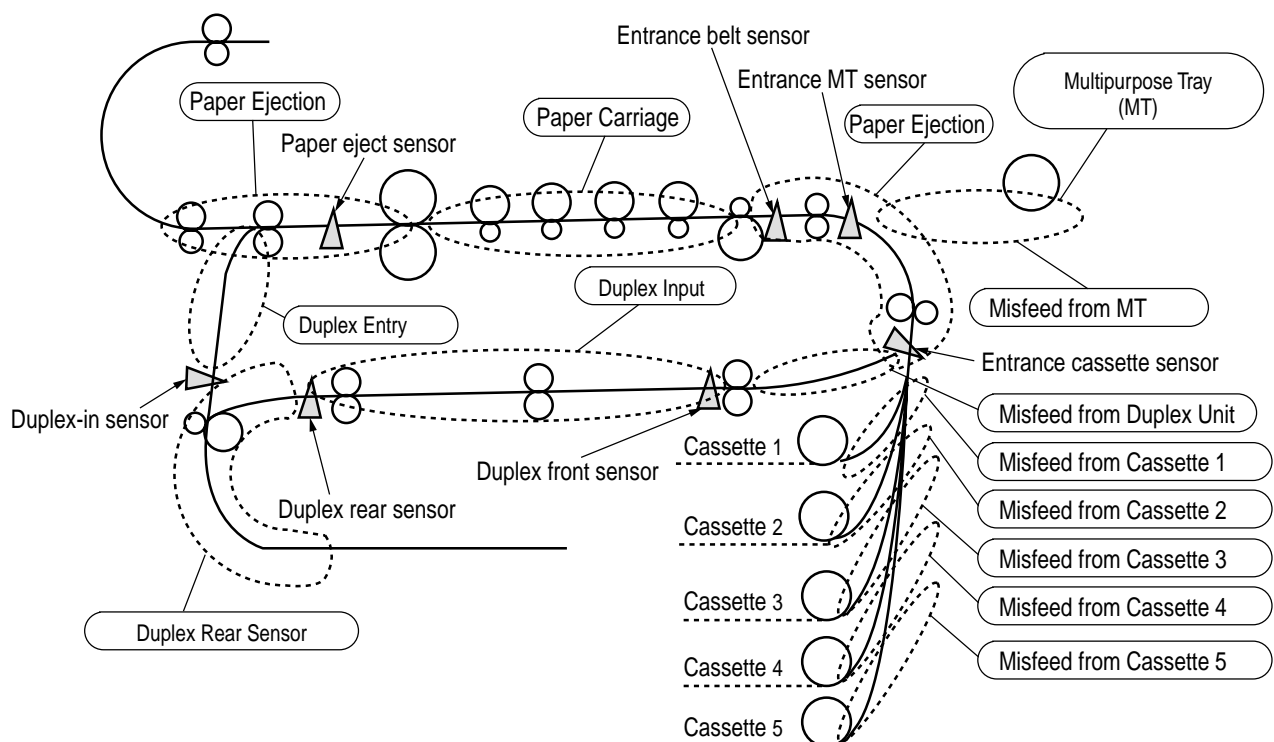

2.9 Cover Opening

When the top cover of the printer is open, the cover open microswitch turns opens to cut off the high-voltage power supply, and outputs which are not less than 32V. At the same time, the CPU receives CVOPN signals indicating the status of the microswitch and performs cover open operations.

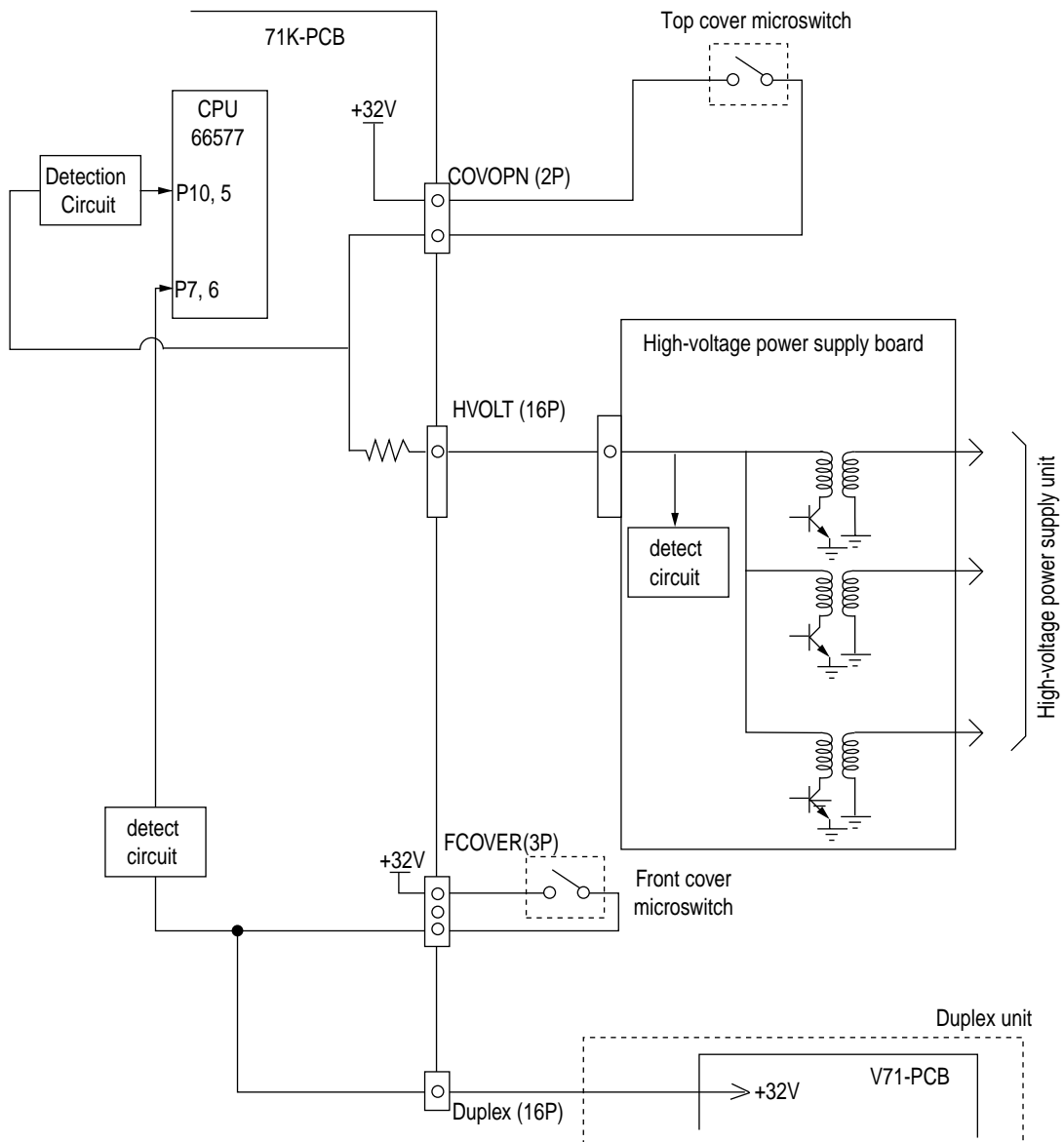

2.10 Toner Low Detection

- Structure

This device consists of the stirring gear which revolves at a constant speed, the stirring bar, and the magnet on the stirring bar. The stirring bar turns in synchronization with the protrusion of the stirring gear.

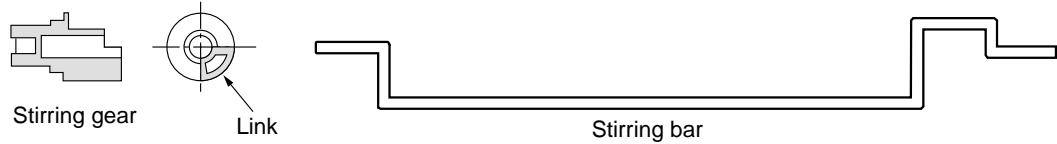

- Detection

A toner low condition is detected by measuring the contact time between the sensor lever magnet and the stirring bar.

Toner Full Condition

- The stirring bar turns in synchronization with the stirring gear.
- Since the opposite side is in toner, the stirring bar turns by the force of the stirring gear even when the stirring magnet is placed in its highest position.

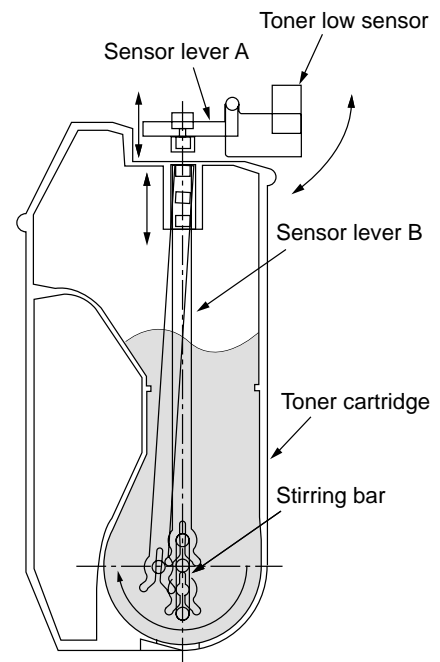

Toner Low Condition

- The stirring bar reaches its highest position, then falls to its lowest position under its own weight because of the absence of toner resistance on the opposite side. In this situation, bar-magnet contact time becomes long. By measuring the time, a toner low condition can be detected.

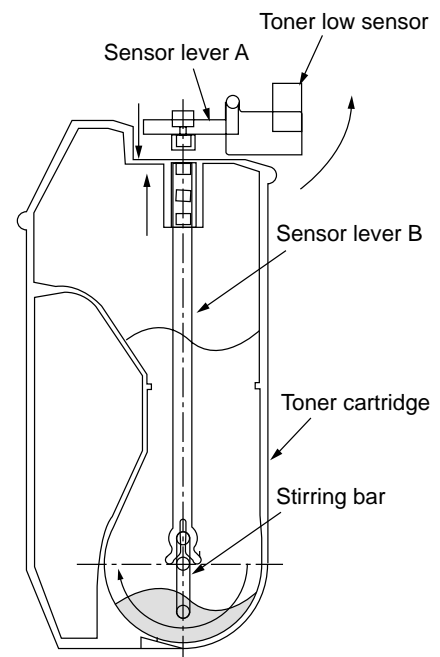

Toner Full Condition (At warming-up,A4 transverse:16ppm *1)

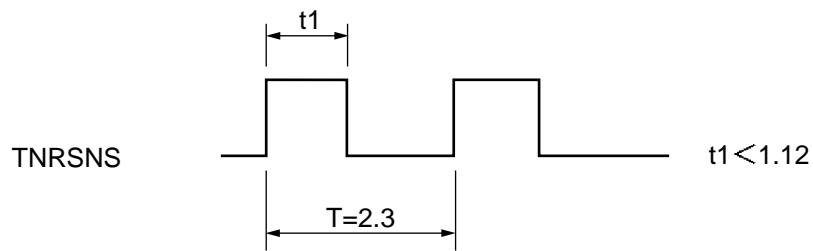

Toner Low Condition (At warming-up,A4 transverse:16ppm *1)

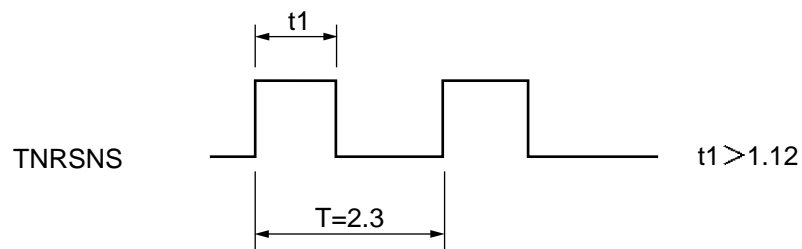

- When the toner low condition is detected 20 consecutive times, toner low is detected.
(The toner low message is displayed when about 1000 A4 sheets at 5% density have been printed after toner low had been detected.)
The detection is not performed until toner low occurs after the detection of toner low.
- When the toner full condition is detected 10 consecutive times, toner low is removed.
- When the toner sensor remains unchanged for more than 15 cycles of 2.3 seconds, the toner sensor alarm is activated.
- The toner sensor does not perform the detection while the drum motor is not running.

* 16ppm is the print speed at warm-up. T and t1 change in proportion to the print speed.

2.11 Paper Size Detection

Via the cam tied to the paper guide of the paper cassette, the four tab pieces are driven according to the set position of the paper guide.

Upon installation of the paper cassette, the microswitch detects the condition of the tab pieces and the paper size is recognized.

	PSZSW1	PSZSW2	PSZSW3	PSZSW4
Without Cassette	0	0	0	0
A3-Nobi	0	0	1	1
Tabloid	1	0	1	1
A3	1	0	0	1
B4	0	0	0	1
Regal 14"	0	1	0	1
Regal 13"	0	1	0	0
A4 in Portrait Orientation	1	1	1	0
Letter in Portrait Orientation	1	1	1	1
Executive	1	1	0	1
B5 in Portrait Orientation	1	1	0	0
Letter in Landscape Orientation	1	0	1	0
A4 in Landscape Orientation	0	0	1	0
A5	0	1	1	0
B5 in Landscape Orientation	1	0	0	0
A6	0	1	1	1

2.12 Operation at Power-on

2.12.1 Self-diagnostic test

- (1) Initial test
The following checks are automatically performed at power-on.
 - (a) ROM check
 - (b) RAM check
 - (c) EEPROM check
 - (d) Flash ROM check
- (2) ROM check
The ROM is checked by calculating a HASH value.
- (3) RAM check
 - (a) Checking is conducted by RAM type. Out-of-specification RAM is judged as an error.
 - (b) The order of mounted RAMs is checked. Out-of-standard RAM is judged as an error.
 - (c) The RAM in each slot is checked by read-after-write operation.
- (4) EEPROM Check
Specific data stored at the fixed EEPROM address is checked.
- (5) Flash ROM Check
The flash ROM format is checked. Unformatted ROM is formatted after the read-after-write checking.
- (6) Option Unit Check
Checking whether the option units (including a HDD, NIC, option trays and the duplex unit) are equipped with the printer is performed.

2.13 Color Misalignment Detection

Reflection-type optical sensors (Z71-PCB) are mounted at the right and left ends of the belt, respectively, in front of the toner scraping (cleaning) blade which is at the back of the belt unit. The color misalignment detection pattern is printed on the belt at the right and left ends each and, by reading the patterns by the reflection-type optical sensors, the misalignment amounts are measured with respect to Black to determine correction values. Then, the misalignment in main-scanning, sub-scanning and slanting directions is corrected.

These operations are performed at power-on, at cover-close and every 400 pages.

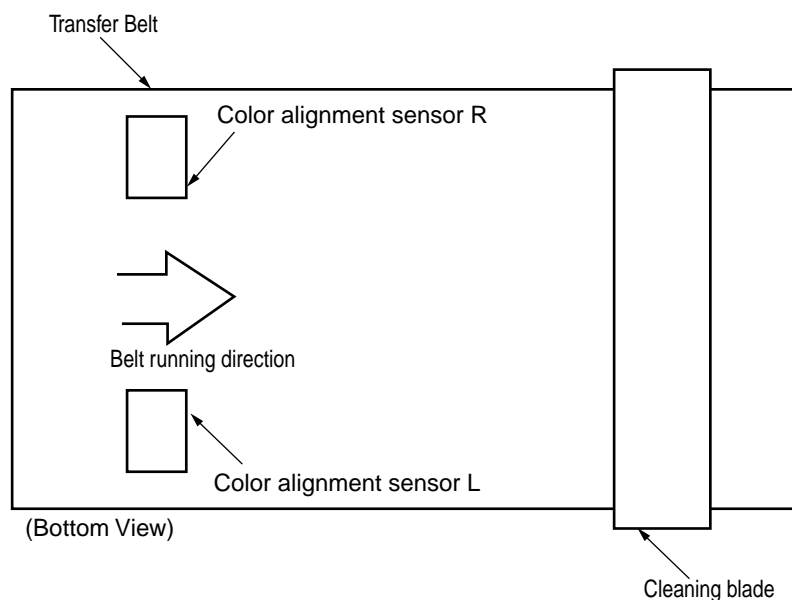
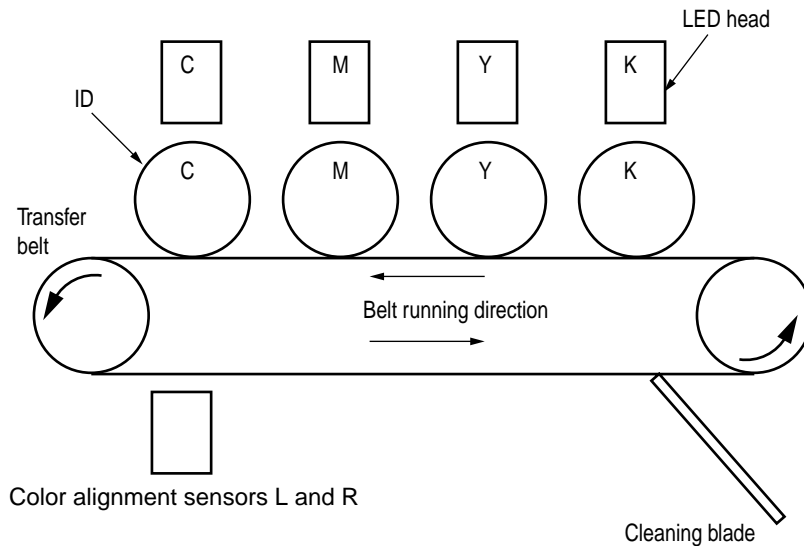

2.14 Version Read of Periodically Replaced Units

The condition (new or used) of the I/D, fuser unit and belt unit are determined by an internal fuse within the units. When the unit is powered on or the upper cover is opened and closed, the printer scans for consumables fuses. If a conducting fuse is found, that unit's counter is reset and the fuse is opened. The life counters of the consumables are checked at each power on and each closing of the upper cover. Once a fuse is opened the consumable is judged used.

2.15 Life Counter for Replaceable Units

Each life of the periodically replaced units - I/D, fuse unit and belt unit is counted as shown in the following table:

Unit Name	Condition	Action
I/D	The number of drum revolutions is counted in the unit of letter paper length + paper interval in continuous printing. End of Life: Time when a distance equivalent to pages of 26K is printed (on 3P/J).	Warning (the unit can still be used).
Toner Cartridge	The number of dots printed is counted. The used amount is determined based on the counter value (See Section 2.16). End of Life: Time when a toner-low error occurs.	Do not use the unit anymore.
Belt Unit	The number of turns revolutions is counted in the unit of letter paper length + paper interval in continuous printing. End of Life: Time when the counter value reaches 80K.	Warning (the unit can still be used).
Fuser Unit	One is counted every time when one page is passed. End of Life: Time when the counter value reaches 80K.	Warning (the unit can still be used).

2.16 Toner Consumption Detection

The used toner amount is detected by counting the number of dots printed.

The counting starts after toner-low is released. The sum of the counted values is stored in EEPROM. When toner-low is detected, the amount used is forcedly set to 7%.

When the equivalent of pages of 1K on A4 and 5% duty is reached after that, toner-empty is detected.

3. PARTS REPLACEMENT

This section describes the procedure for replacing the parts, assemblies and units in the field. The replacing procedure is given for detachment. To attach, use the reverse procedure.

3.1 Precautions in Replacing Parts

- (1) Before replacing the parts, be sure to remove the AC cable and the interface cable.
 - (a) To remove the AC cable, always use the following procedure.
 - ① Flip the power switch of the printer off (to "O").
 - ② Pull the AC inlet plug of the AC cable out of the AC receptacle.
 - ③ Remove the AC cable and the interface cable from the printer.
 - (b) To connect the printer again, always use the following procedure.
 - ① Connect the AC cable and the interface cable to the printer.
 - ② Insert the AC inlet plug into the AC receptacle.
 - ③ Flip the power switch of the printer on (to "I").

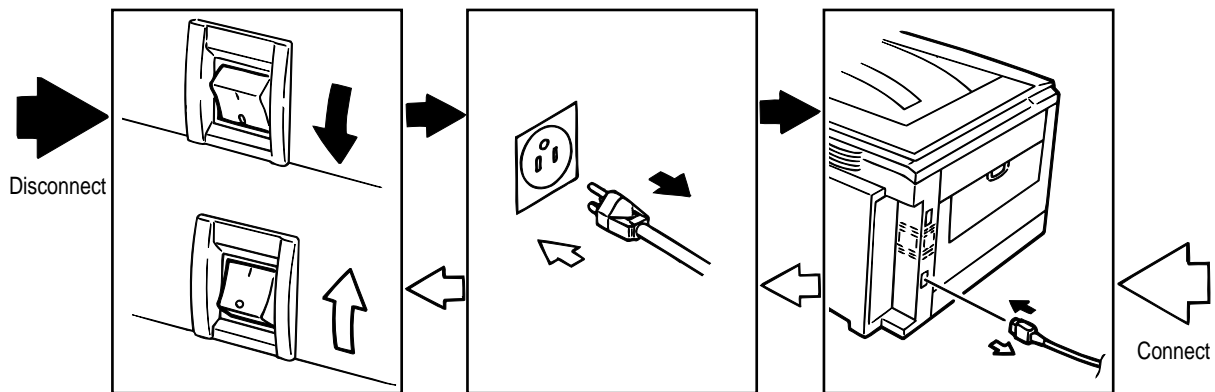





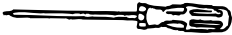
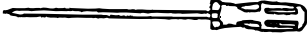

- (2) Do not disassemble the printer so long as it operates properly.
- (3) Minimize the disassembly. Do not detach parts other than those shown in the replacing procedure.
- (4) For maintenance applications, use designated tools.
- (5) Follow the order instructed to disassemble the printer. Incorrect order may damage the parts.
- (6) Small parts such as screws and collars tend to get lost, so temporarily replace them in their original positions.
- (7) When handling ICs and circuit boards such as microprocessors, ROMs and RAMs, do not use gloves that are likely to have static.
- (8) Do not place the printed circuit boards directly on the printer or the floor.

[Maintenance Tools]

Table 3-1 lists tools necessary to replace the units.

Table 3-1 Maintenance Tools

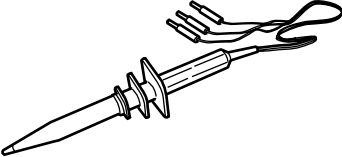
No.	Service Tools	Q' ty	Place of use	Remarks
1	 No. 1-100 Philips screwdriver	1	2~2.5 mm screws	
2	 No. 2-200 Philips screwdriver, Magnetized	1	3~5 mm screws	
3	 No. 3-100 screwdriver	1		
4	 No. 5-200 screwdriver	1		
5	 Digital multimeter	1		
6	 Pliers	1		
7	 Handy cleaner	1		
8	 LED Head cleaner P/N 4PB4083-2248P001	1	Cleans LED head	
9	 High voltage probe	1		

3.2 Parts Layout

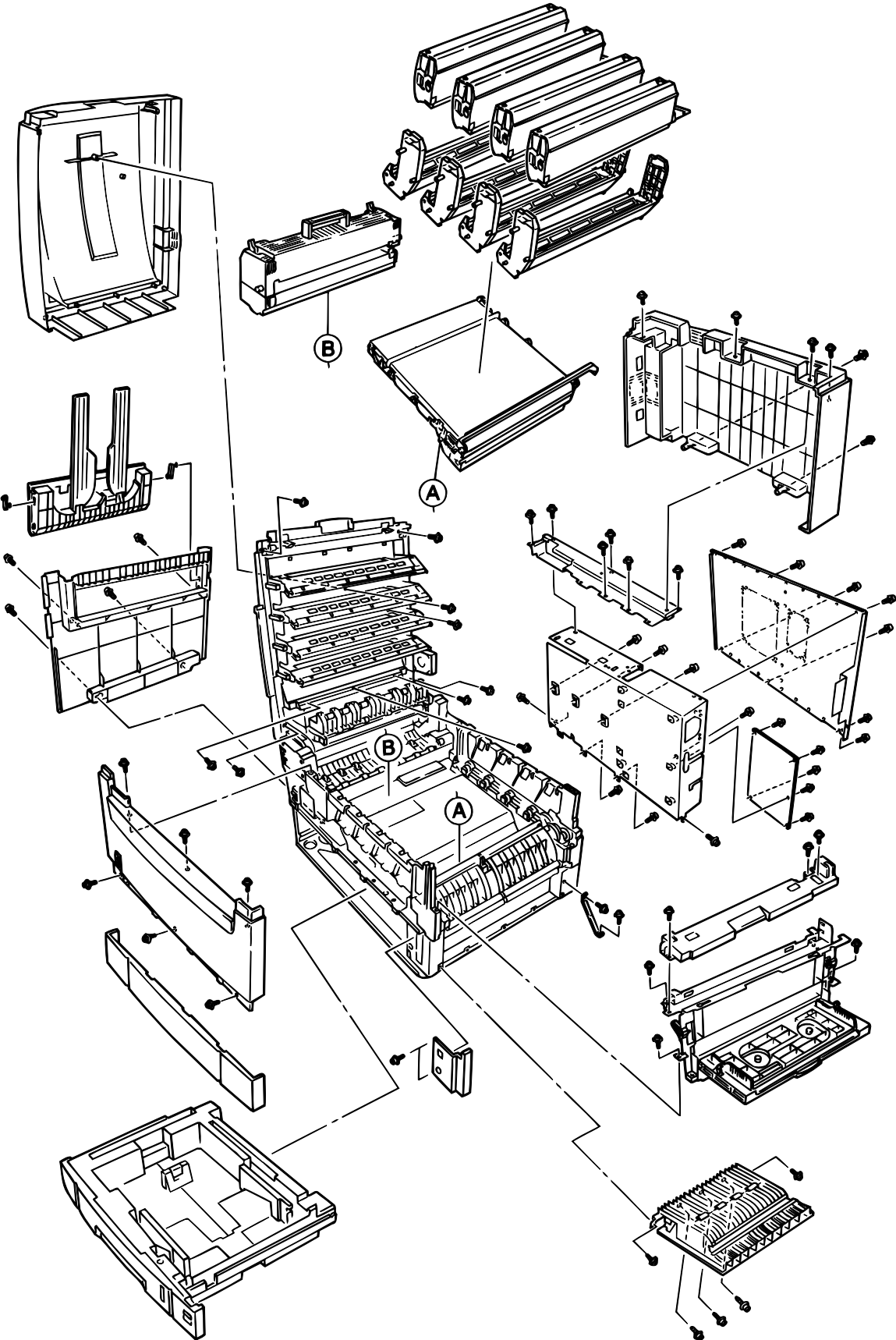

Figure 3.1

[Top Cover Assy]

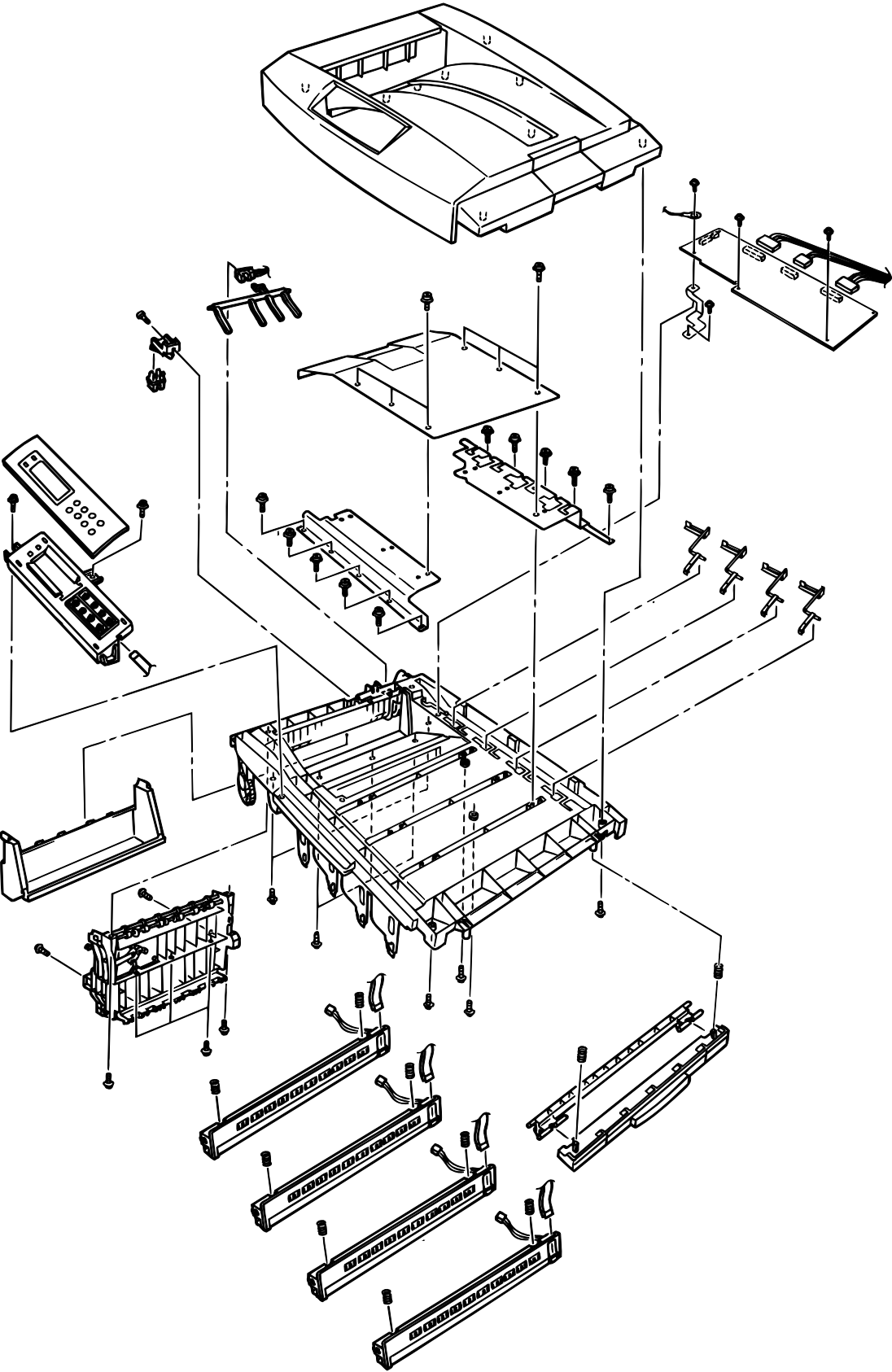

Figure 3.2

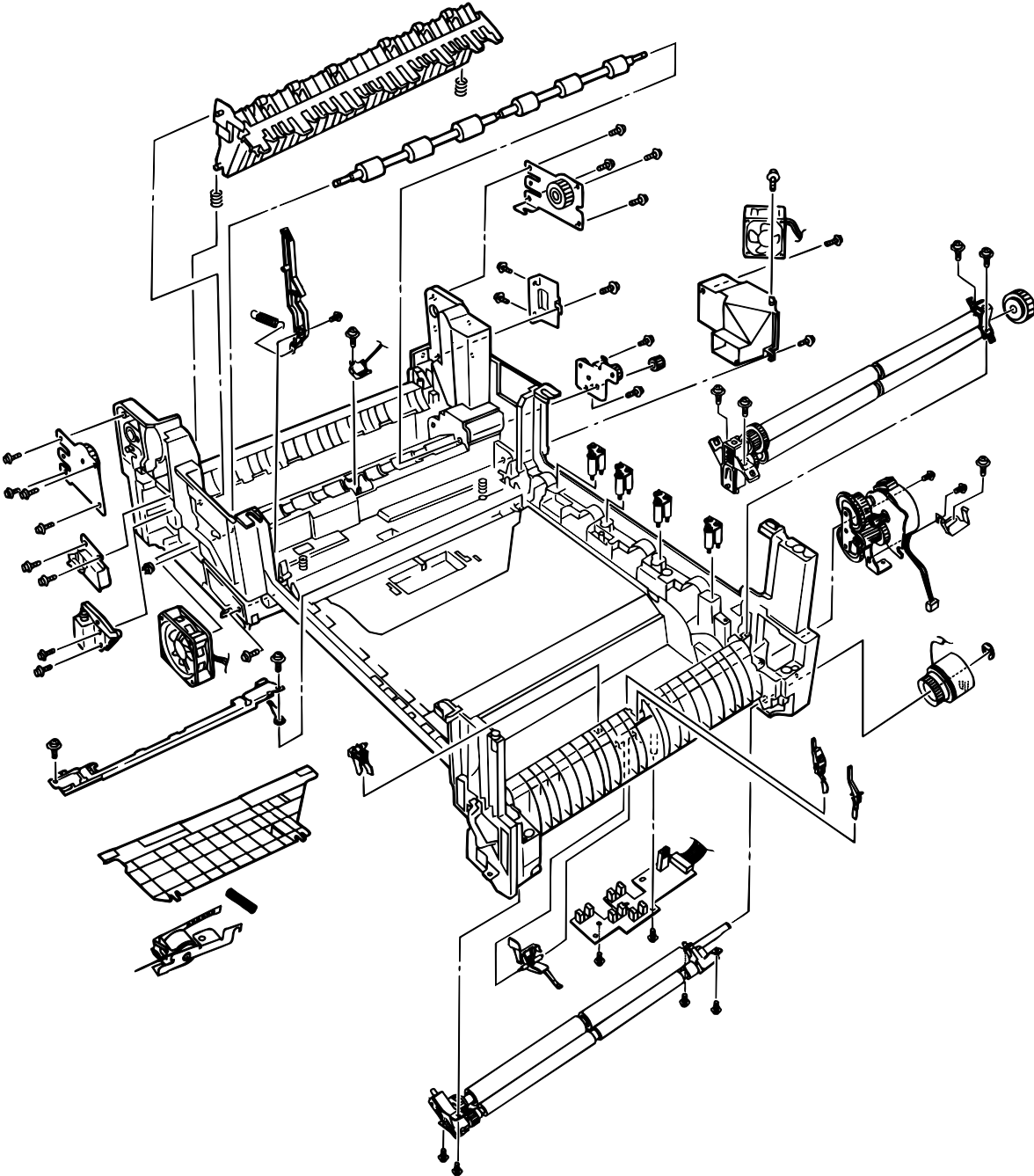

Figure 3.3

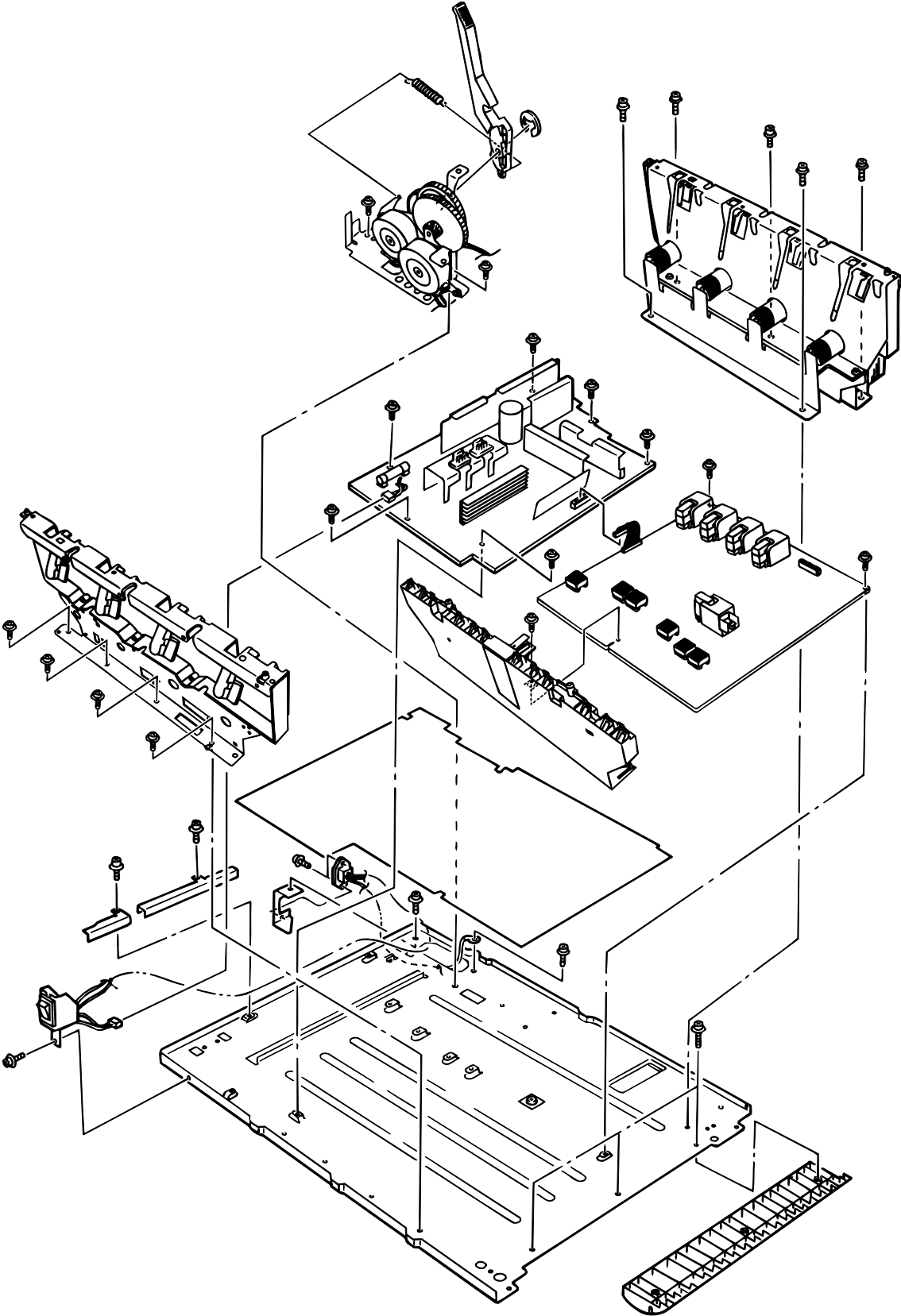

Figure 3.4

[Cassette Guide Assy (L), (R)]

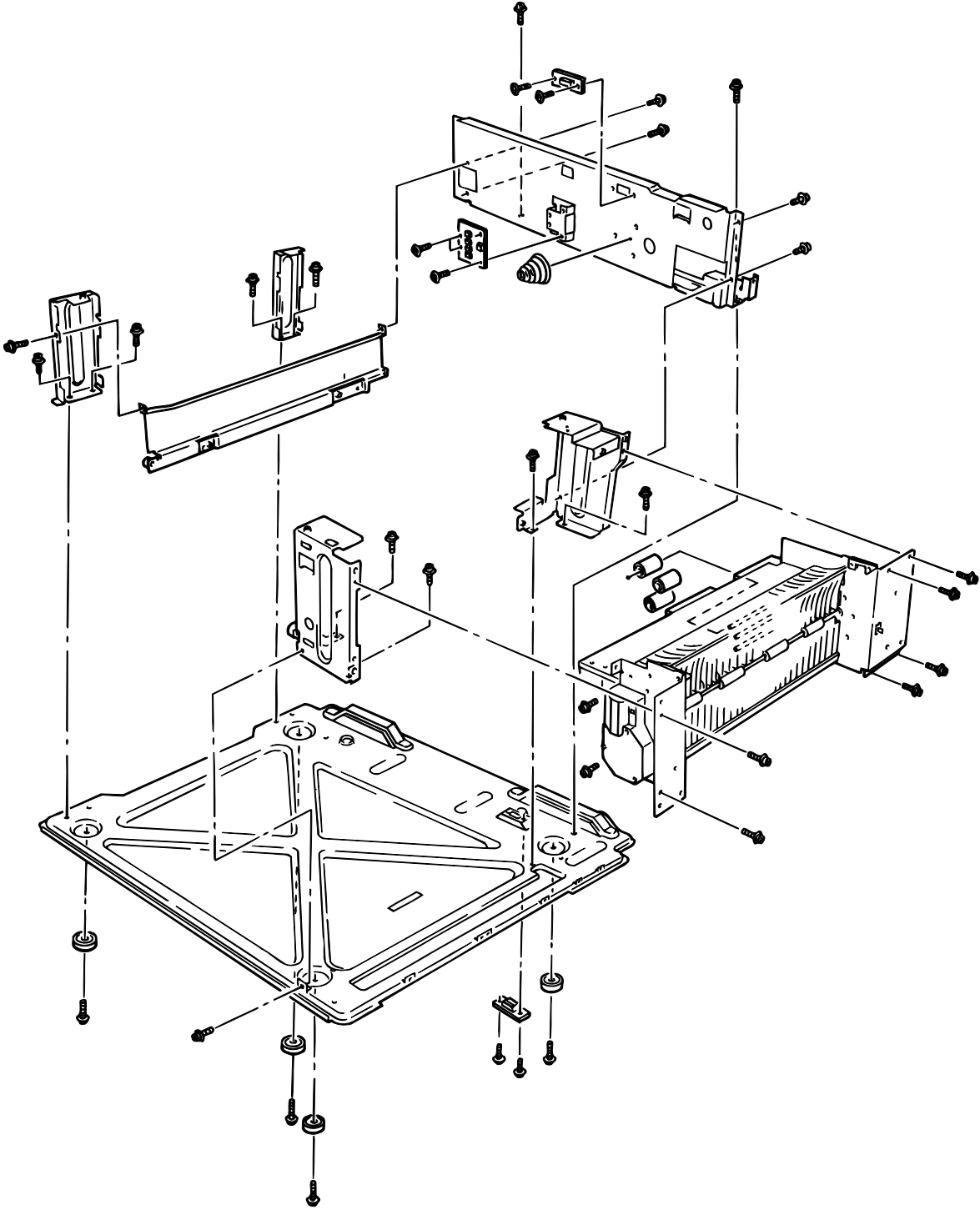
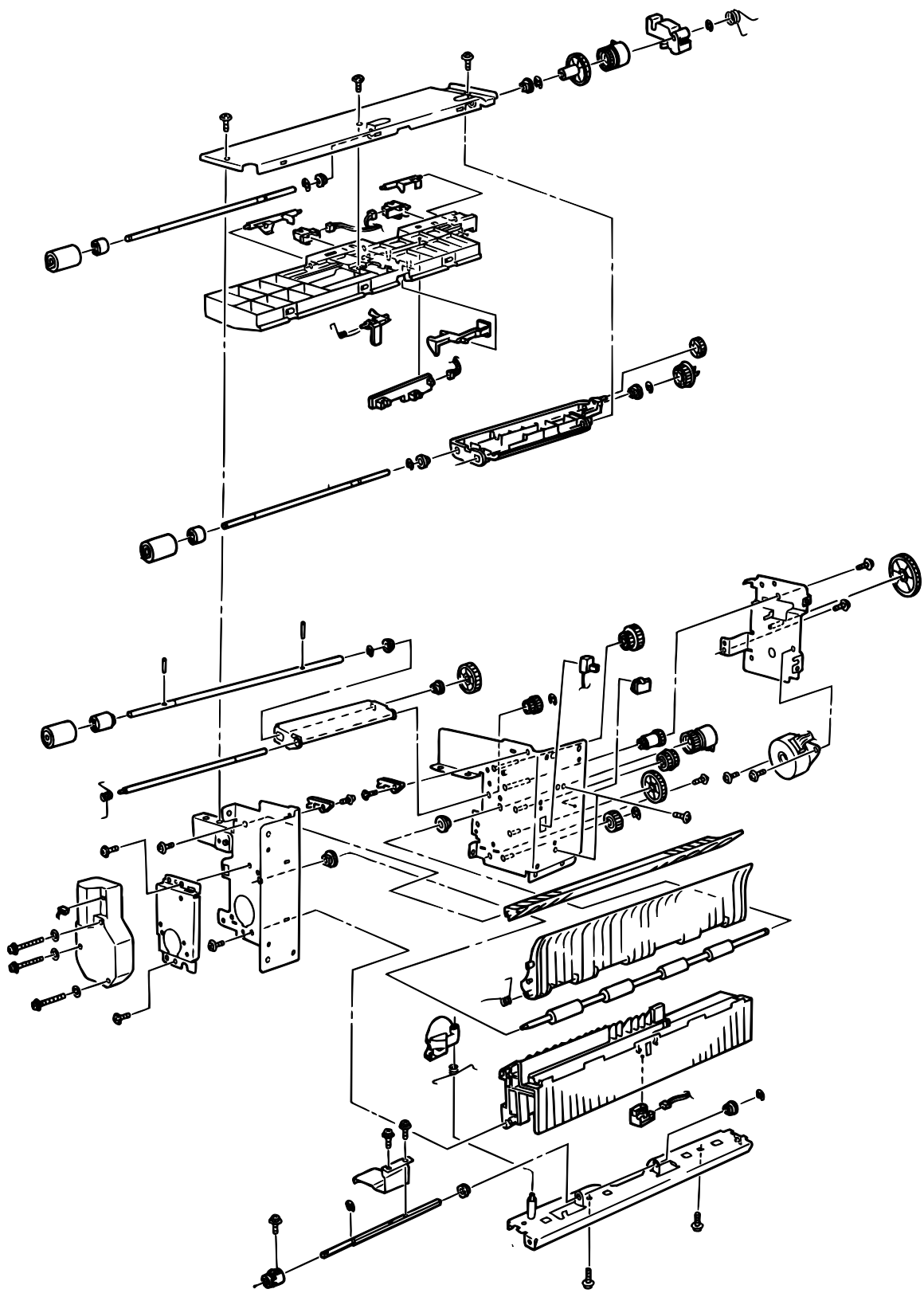

Figure 3.5



[Duplex Unit]

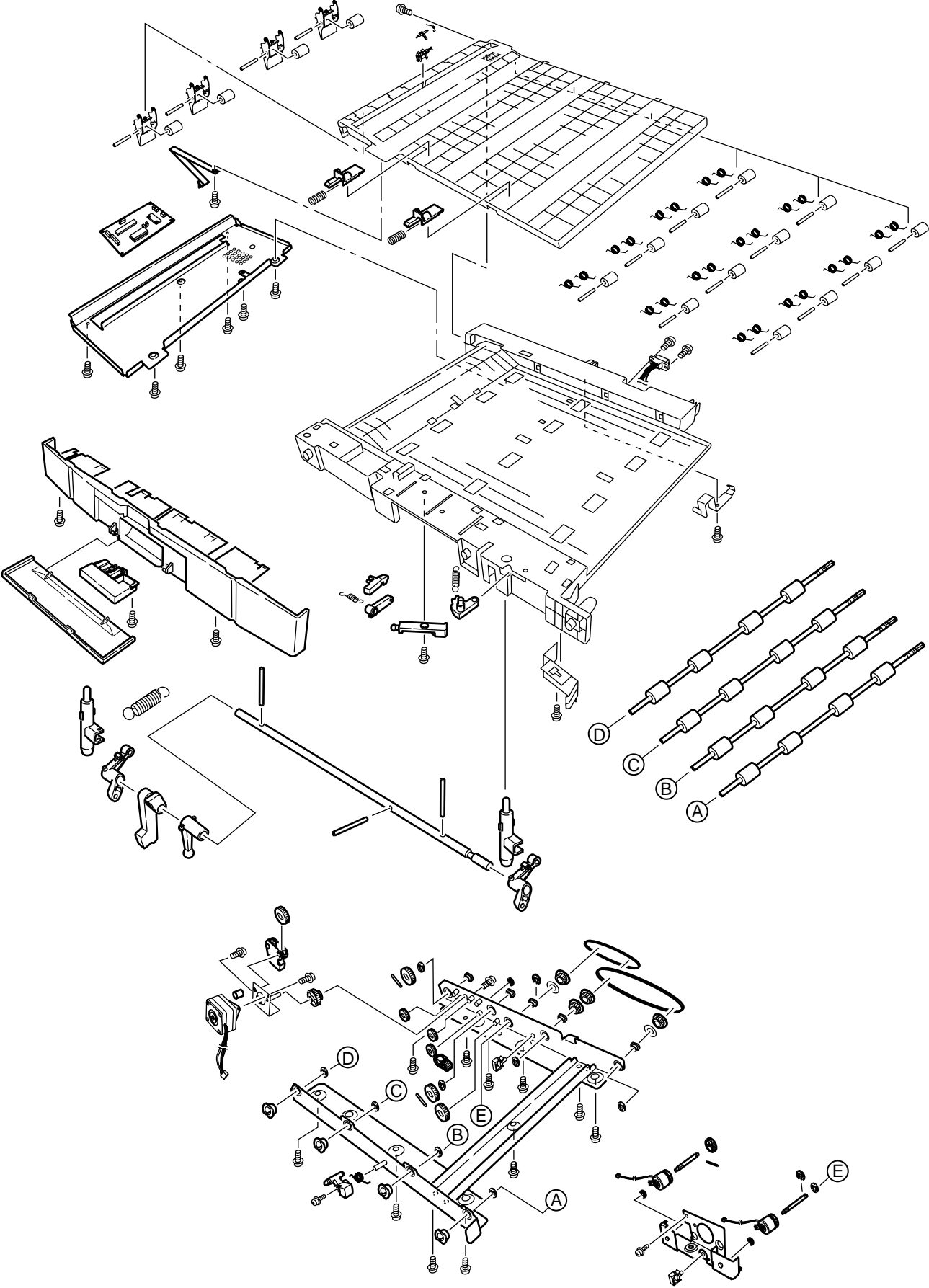
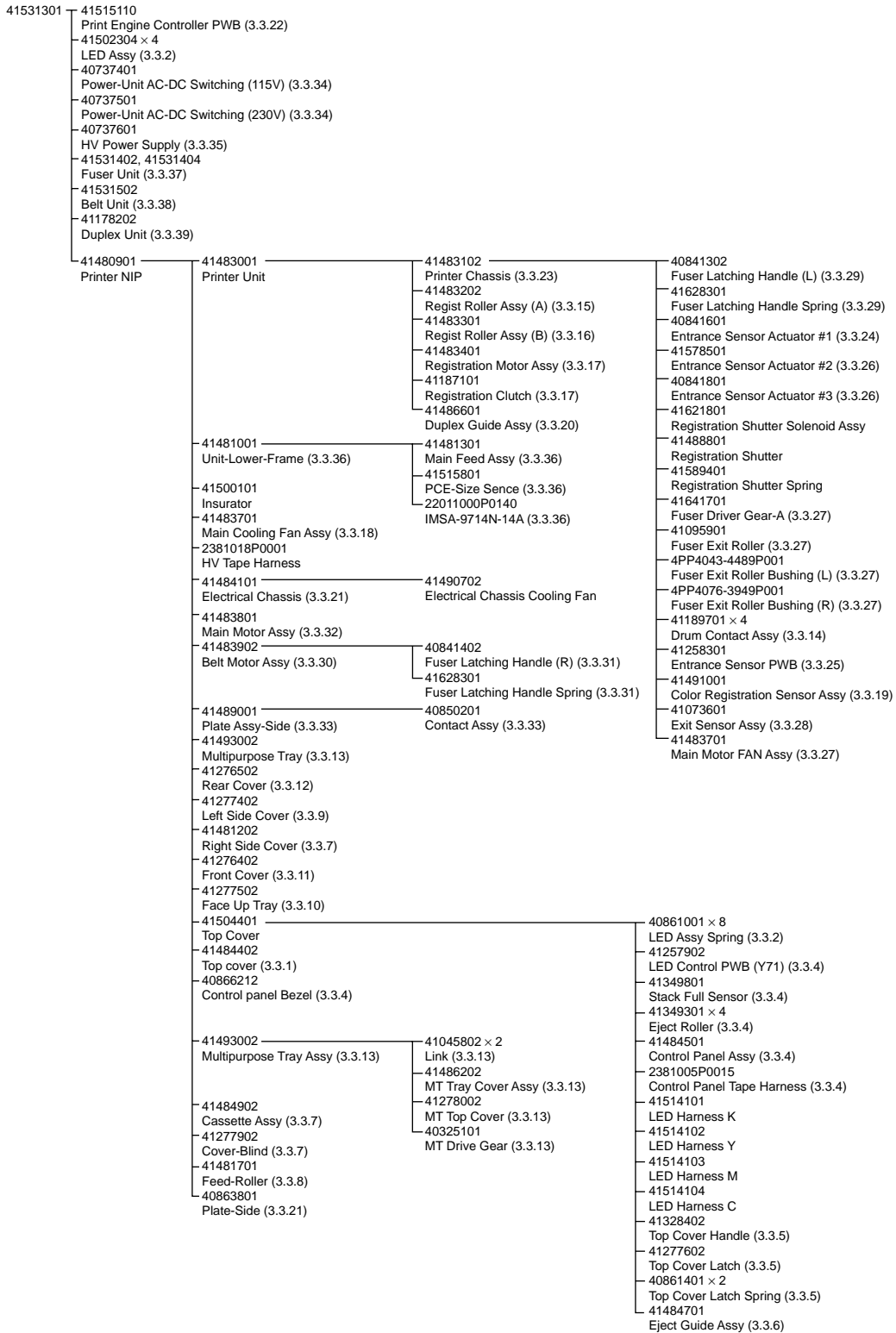

Figure 3.6

3.3 Replacing Parts

This section describes how to replace the parts and assemblies illustrated below.



3.3.1 Top cover

- (1) Open the top cover Assy.
- (2) Remove the nine screws ① to detach the top cover ②.

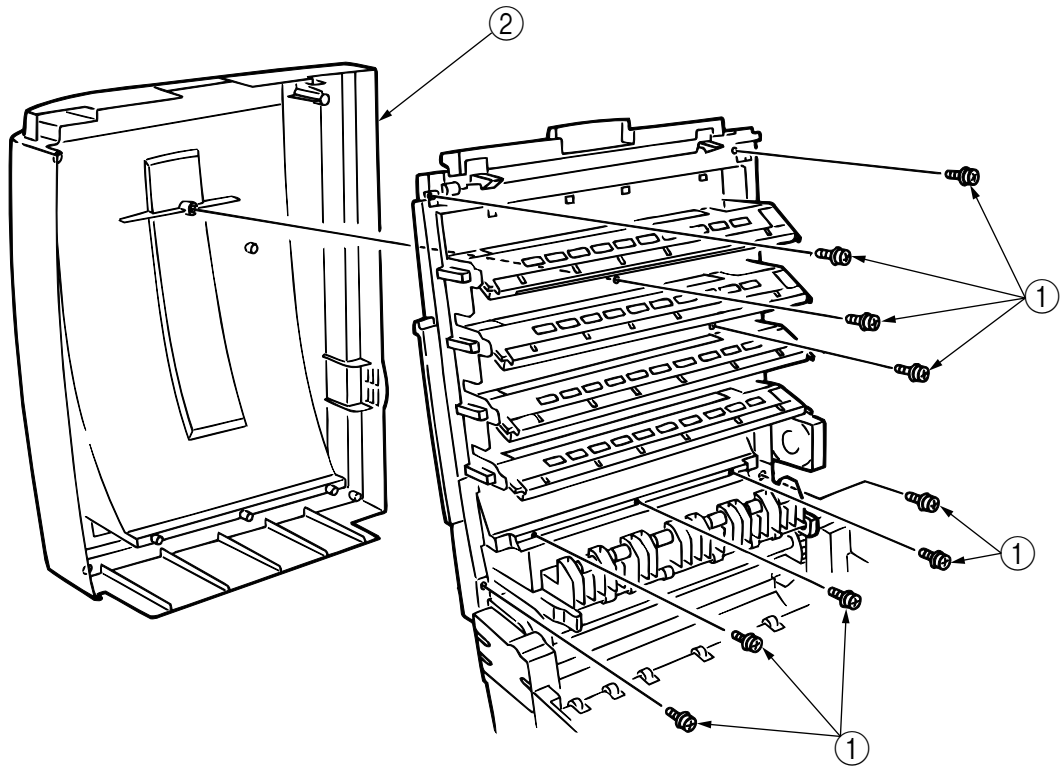

3.3.2 LED Assy/ LED Assy spring

- (1) Open the top cover ①.
- (2) Remove the three cables, and unhook the LED Assy ② at the two places to demount it (The two springs ③ become detached together with the LED Assy ②).
- (3) Detach the LED connector ④.

When assembling, attach the LED connector ④ to the LED head and insert the flat cable.

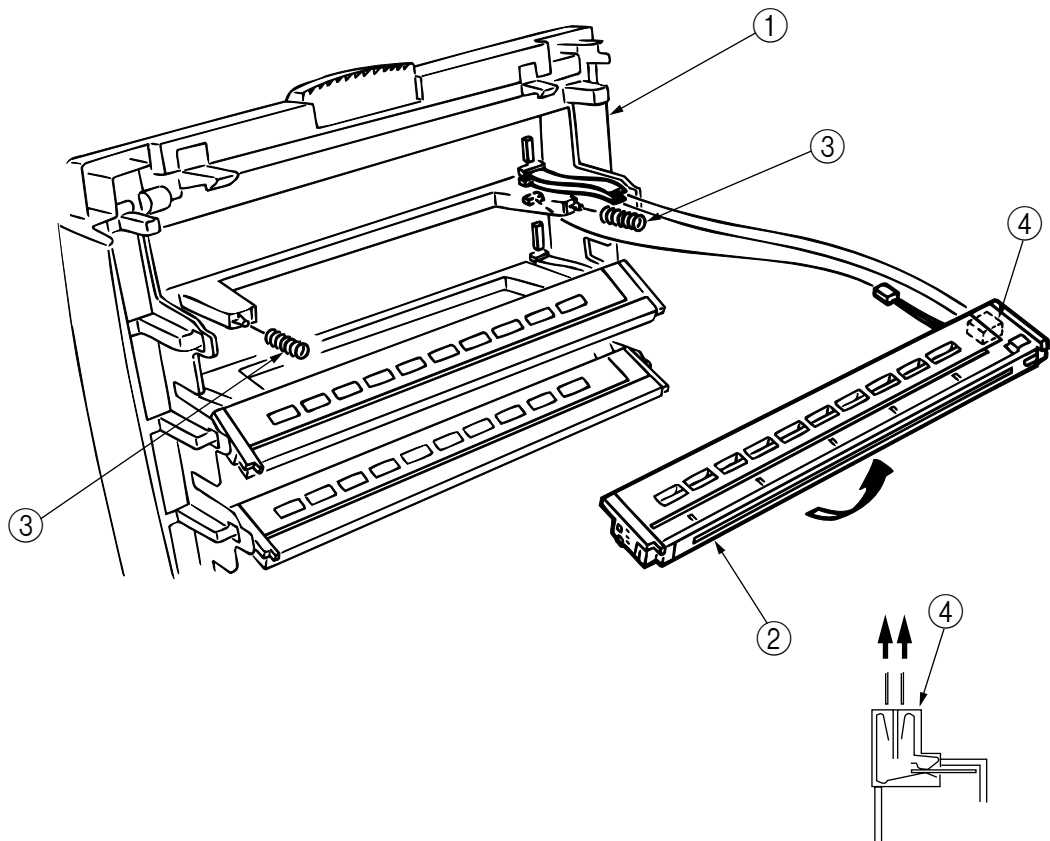

3.3.3 Top cover unit

- (1) Remove the top cover (see section 3.3.1).
- (2) Remove the rear cover (see section 3.3.12).
- (3) Remove the front cover (see section 3.3.11).
- (4) Remove the electrical chassis (see section 3.3.21).
- (5) Unscrew the screws ① and ② to remove the limiters (F) ③ and (R) ④.
- (6) Remove the inner shaft ⑤, then the top cover unit ⑧ (The inner springs ⑥ and ⑦ become detached).

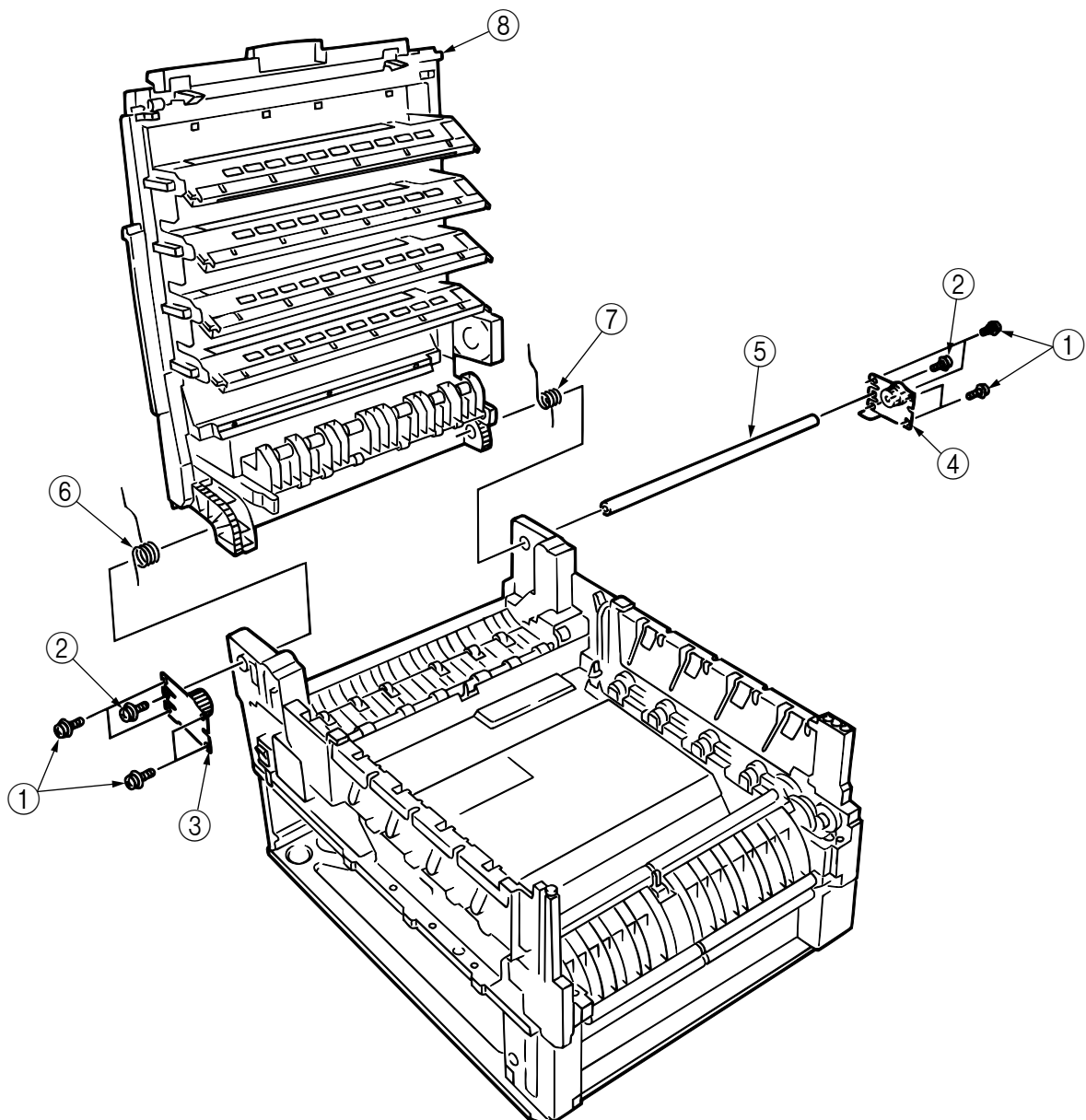

3.3.4 Control panel Assy/ Control panel bezel/ LED control PWB/ Toner sensor/ Stack full sensor/ Control panel tape harness/ Eject roller

- (1) Detach the control panel bezel ①.
- (2) Remove the screws ② to demount the control panel ③.
- (3) Detach the control panel tape harness ④.
- (4) Remove the screws ⑥, unhook the connector ⑦ and demount the LED control PWB ⑧.
- (5) Unscrew the screws ⑨ to remove the plate ⑩.
- (6) Disengage the claw to demount the toner sensor ⑪.
- (7) Demount the stacker full sensor ⑫.
- (8) Unscrew the eject sensor bracket ⑬, ⑭.

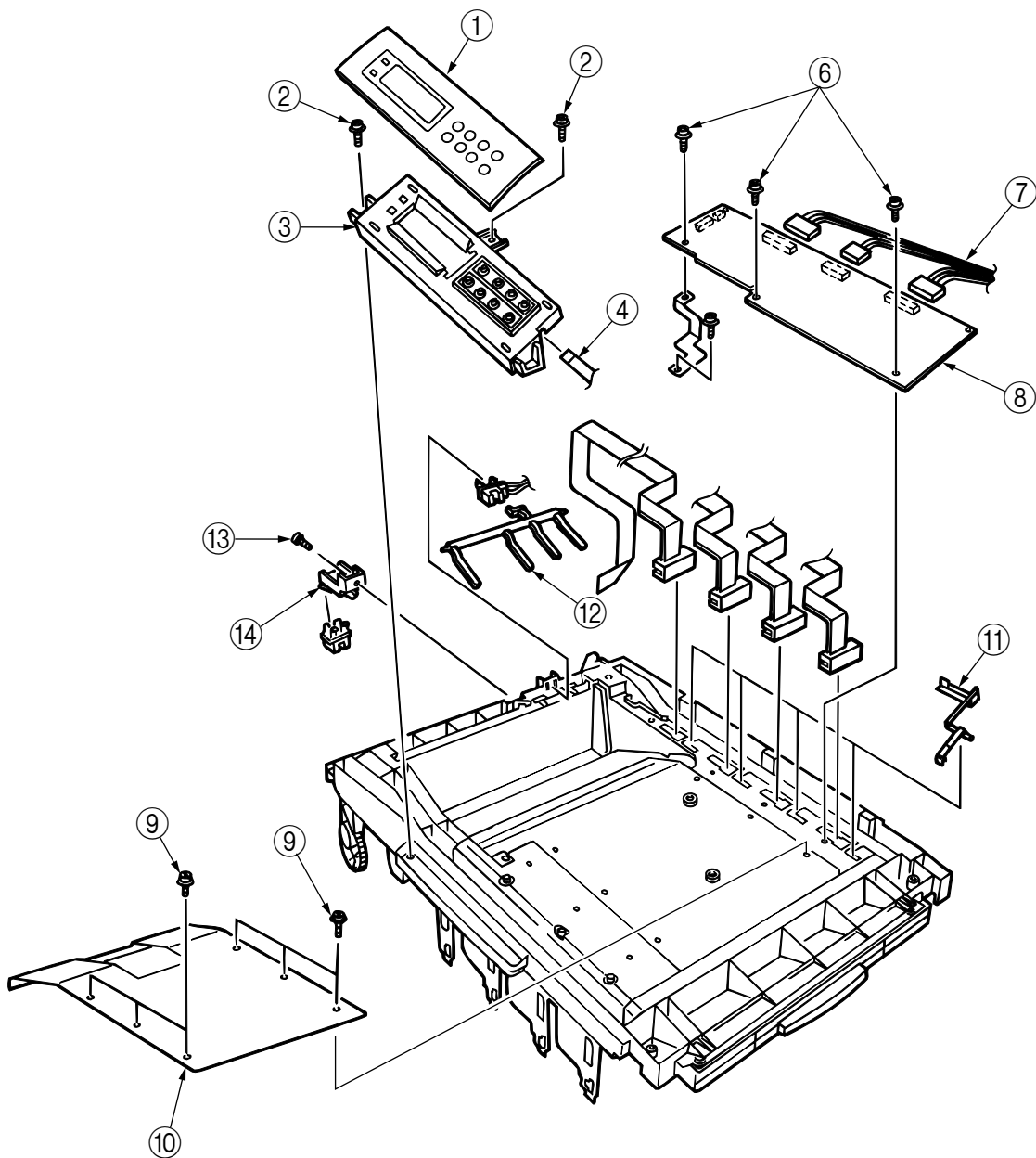

3.3.5 Top cover handle/ Top cover latch/ Top cover latch spring

- (1) Remove the two screws ① to detach the top cover handle ② and disengage the top cover latch ③ (The two top cover latch springs ④ become detached).

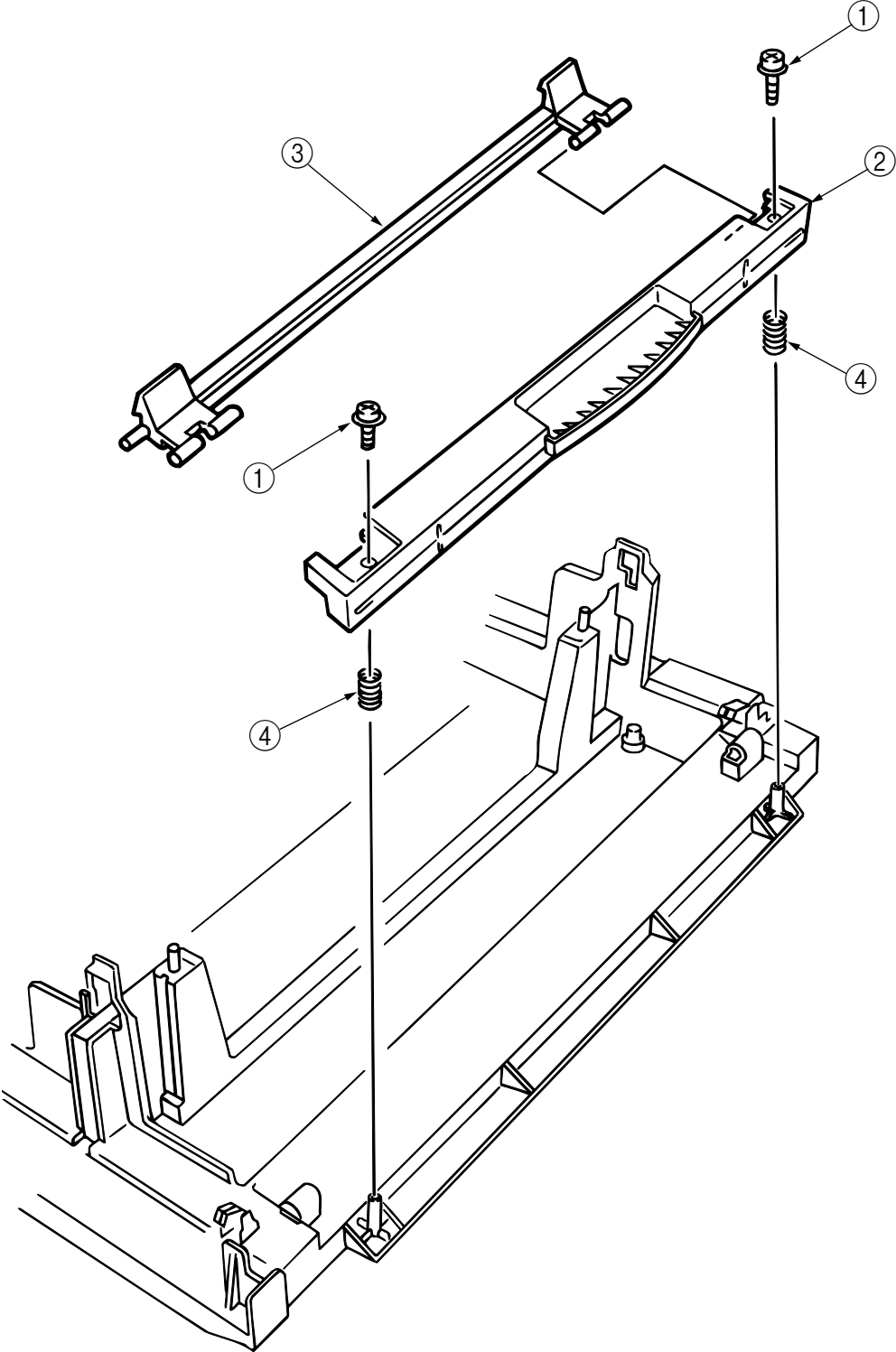

3.3.6 Eject guide Assy

(1) Remove the seven screws ① to detach the eject guide Assy ②.

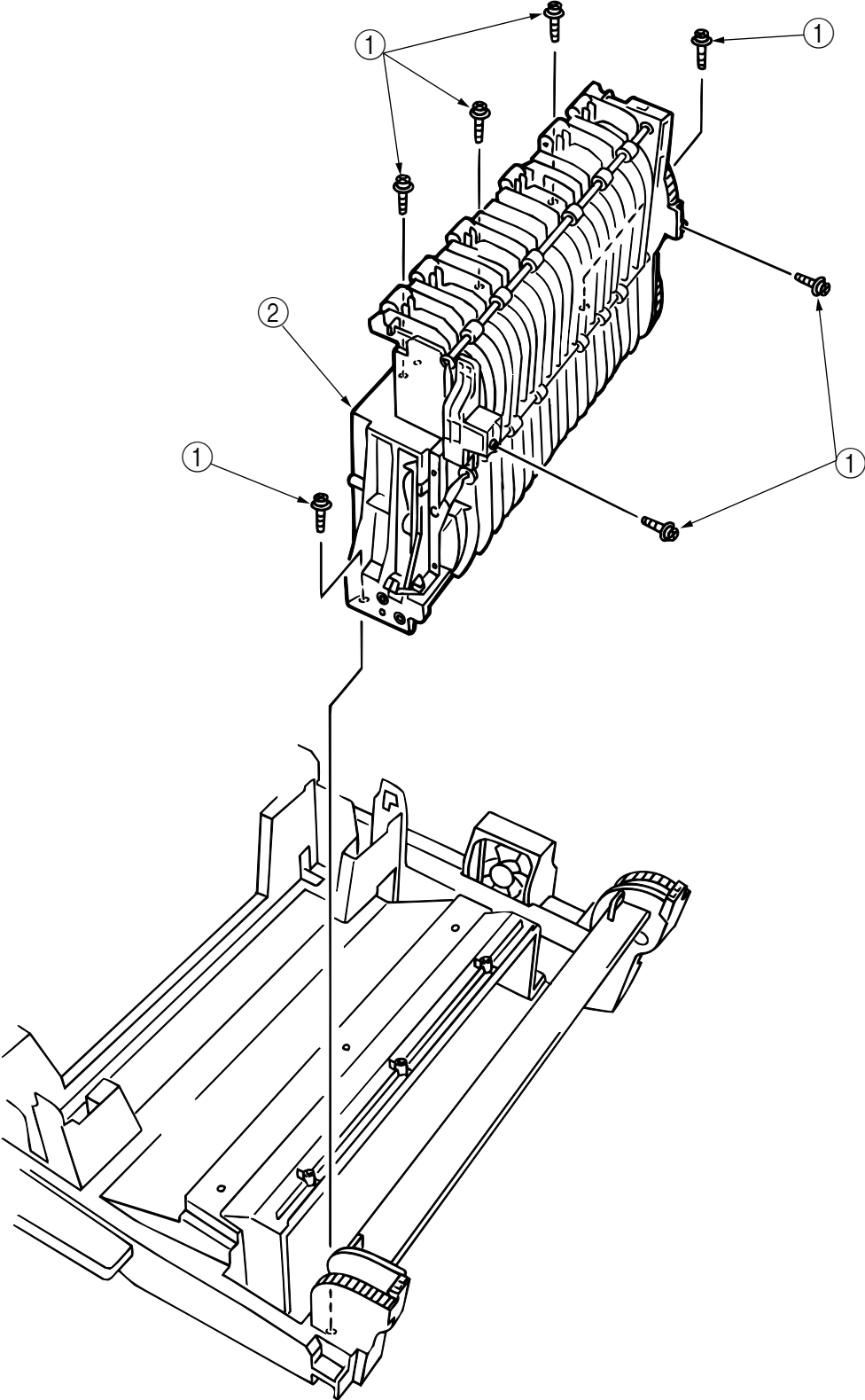

3.3.7 Cassette Assy/ Blind cover/ Side cover R Assy

- (1) Detach the cassette Assy ①.
- (2) Disengage the blind cover ② at the two places to detach it.
- (3) Unscrew the two screws to remove the stopper ④.
- (4) Disengage the claw on the left support of the side cover R to detach the side cover R.

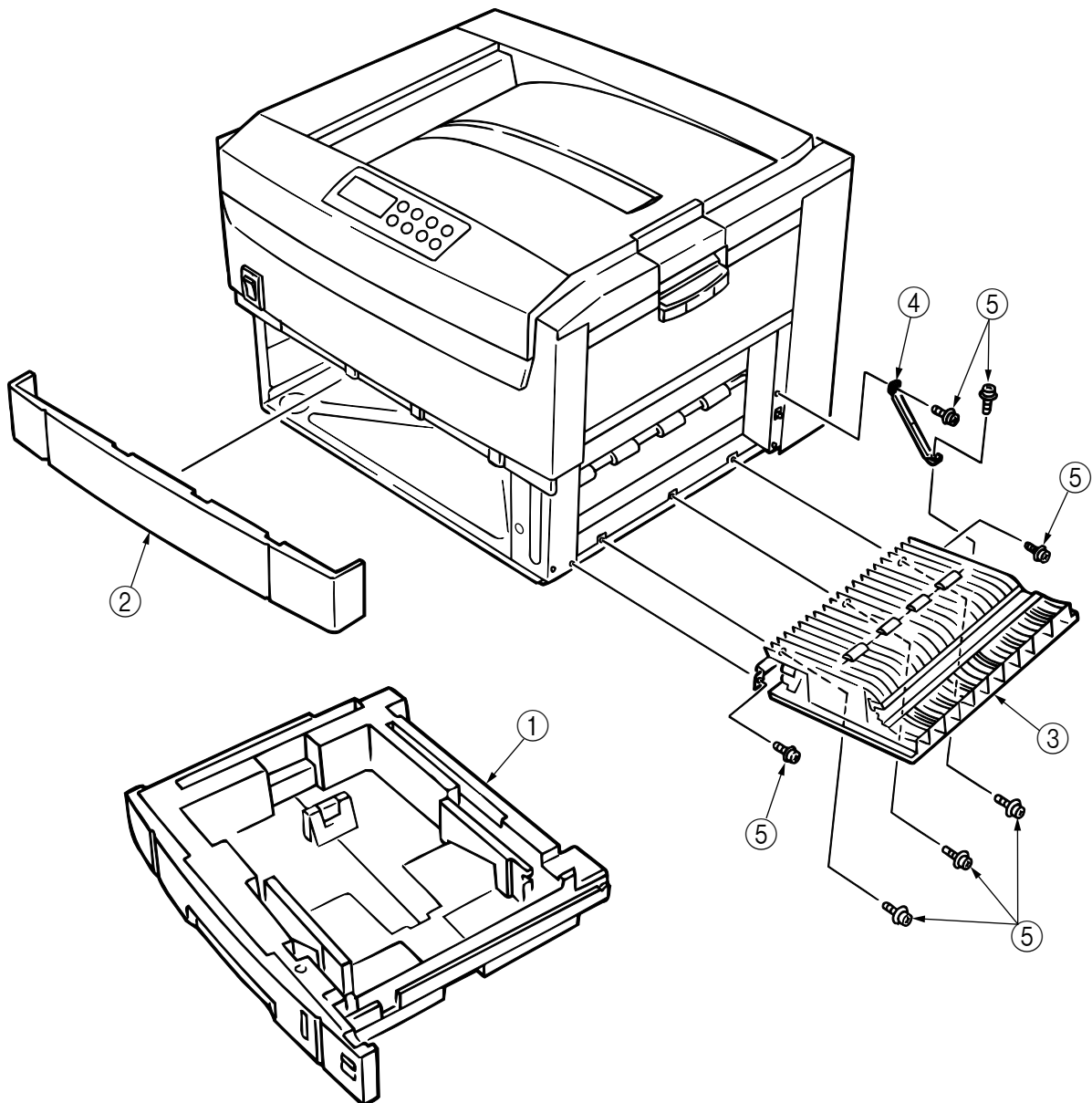

3.3.8 Feed rollers

- (1) Remove the cassette.
- (2) Unlatch and demount the feed rollers ①.

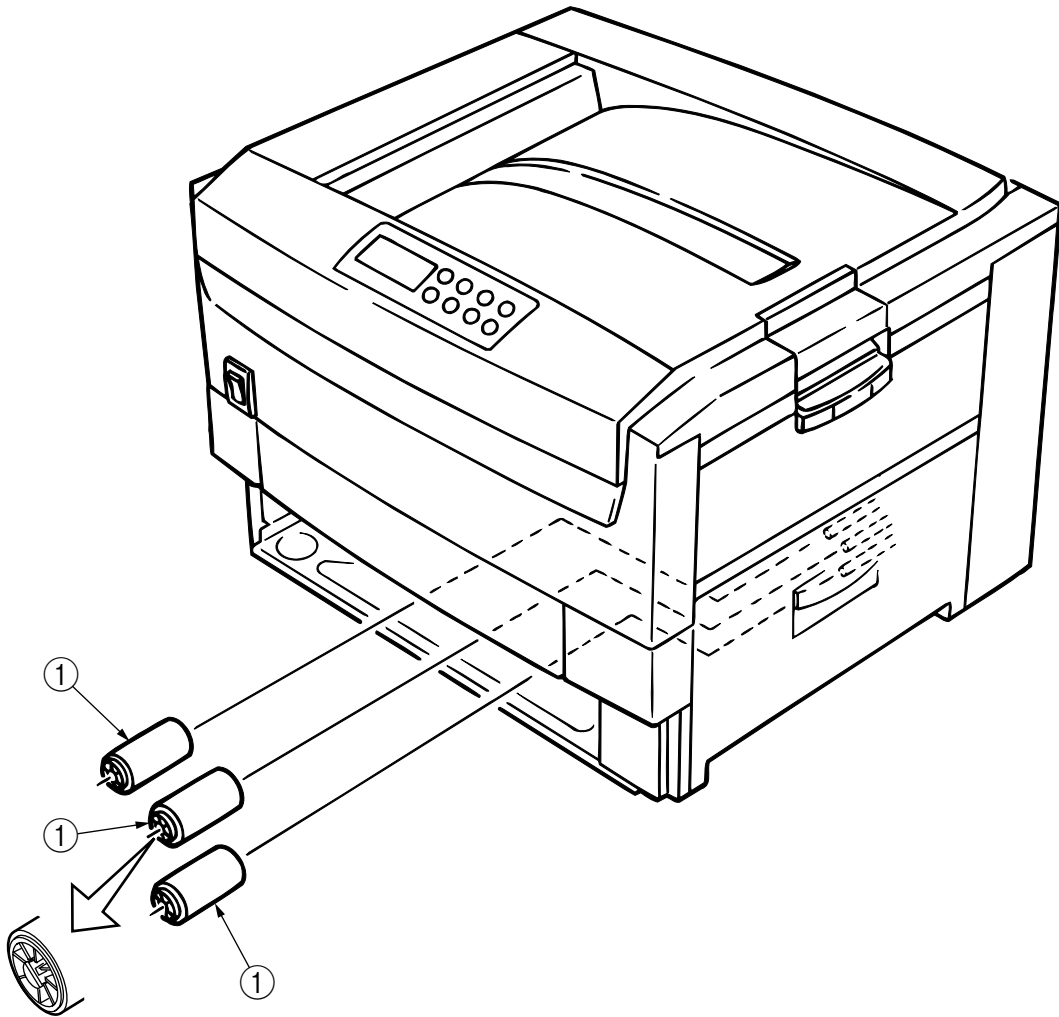

3.3.9 Left side cover

(1) Remove the four screws ① to detach the left side cover ②.

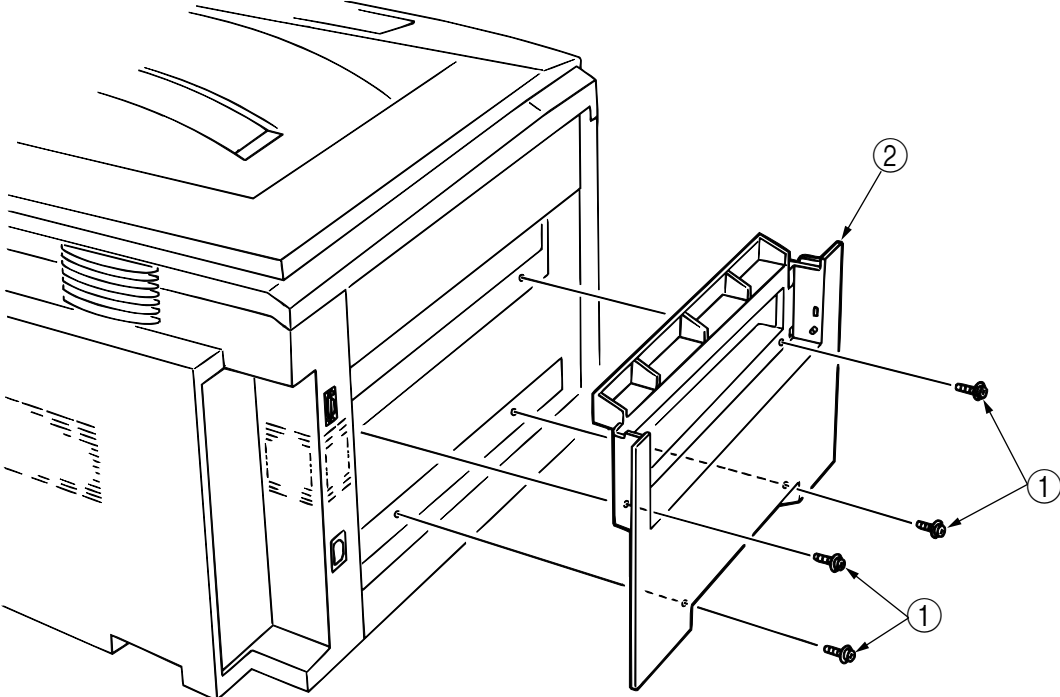

3.3.10 Face-up tray

- (1) Open the face-up tray in the arrow direction and move the links ② out of engagement (at two places each of the links) to detach the face-up tray ①.

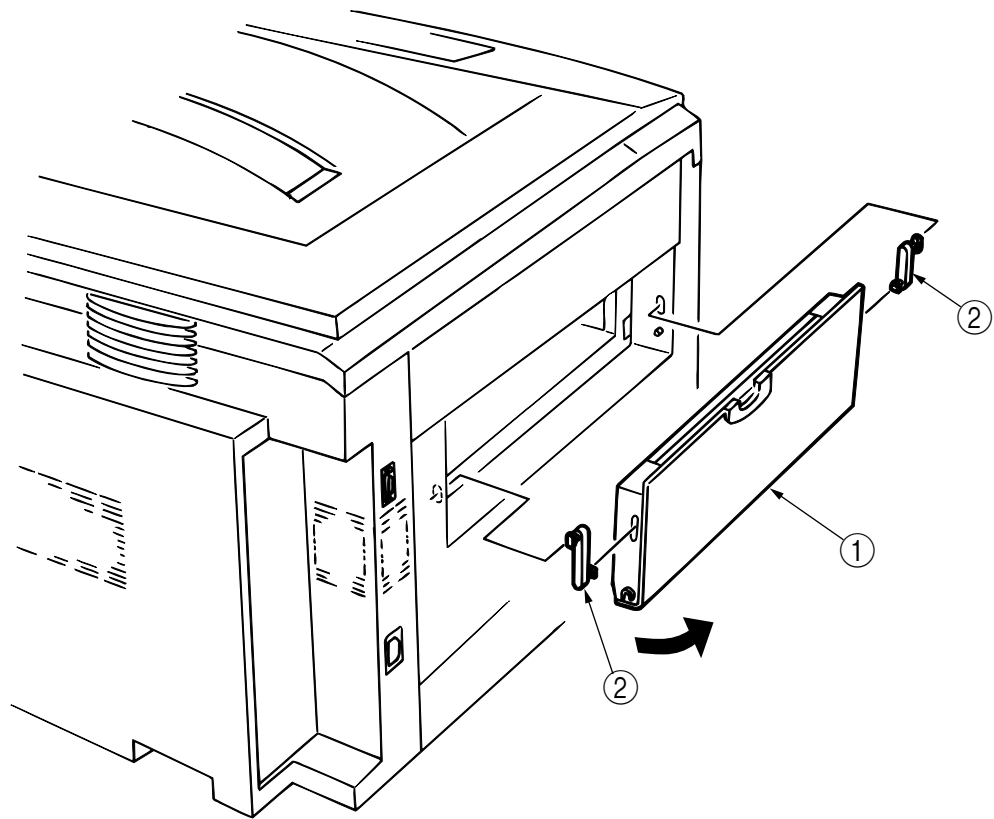

3.3.11 Front cover

- (1) Open the top cover ①.
- (2) Disengage the claws and remove the blind cover ②.
- (3) Unscrew the six screws ④ to detach the front cover ③.

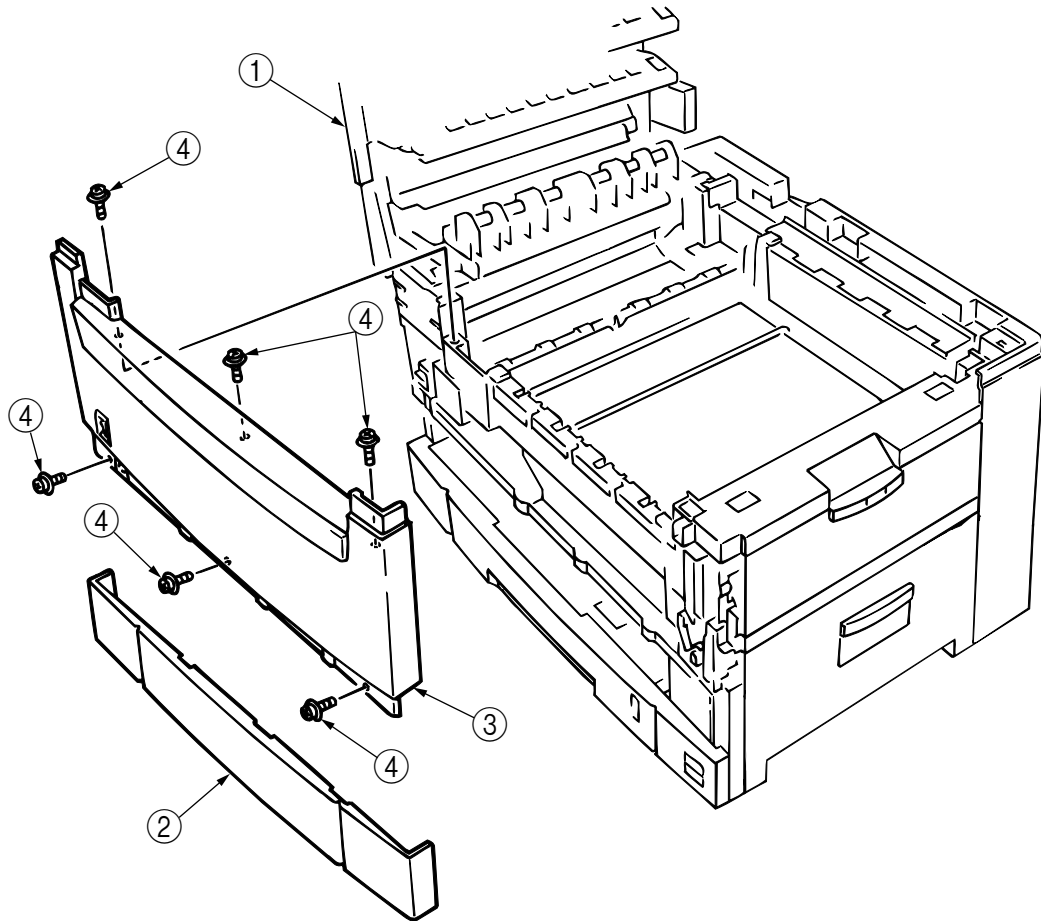

3.3.12 Rear cover

- (1) Open the top cover ①,
- (2) Remove the five screws ③ and ④ to detach the rear cover ②.

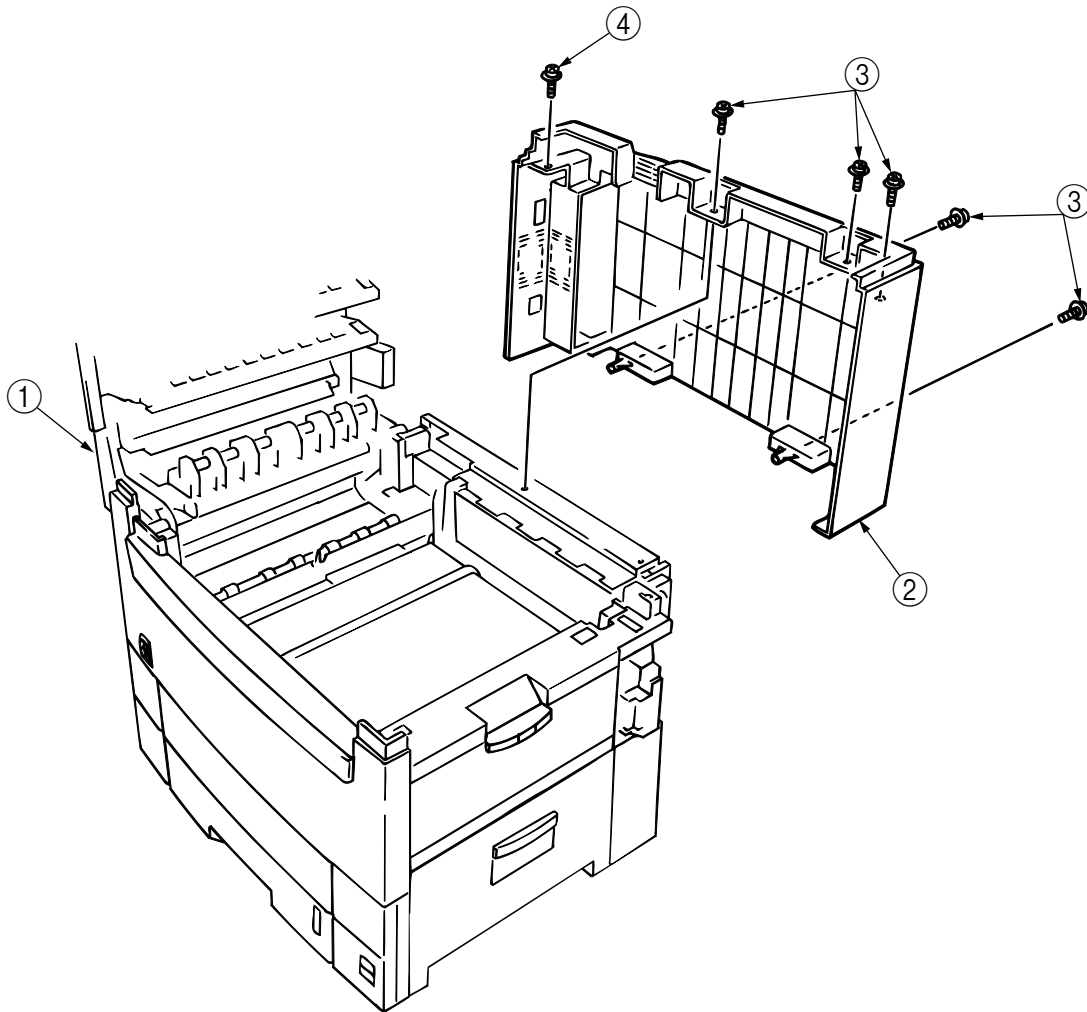

3.3.13 Multipurpose tray Assy/ Multipurpose tray cover Assy/ Links/ Multipurpose tray top cover/ Multipurpose tray drive gear

- (1) Remove the rear cover (see section 3.3.12).
- (2) Remove the front cover (see section 3.3.11).
- (3) Unscrew the three screws ① to detach the multipurpose tray top cover ②.
- (4) Unscrew the two screws ③ and remove the connector to detach the multipurpose tray ④.
- (5) Disengage ④ and ⑤ to detach the multipurpose tray cover Assy ⑤ (the links ⑦ become detached).
- (6) Unhook and detach the multipurpose tray drive gear ⑧.

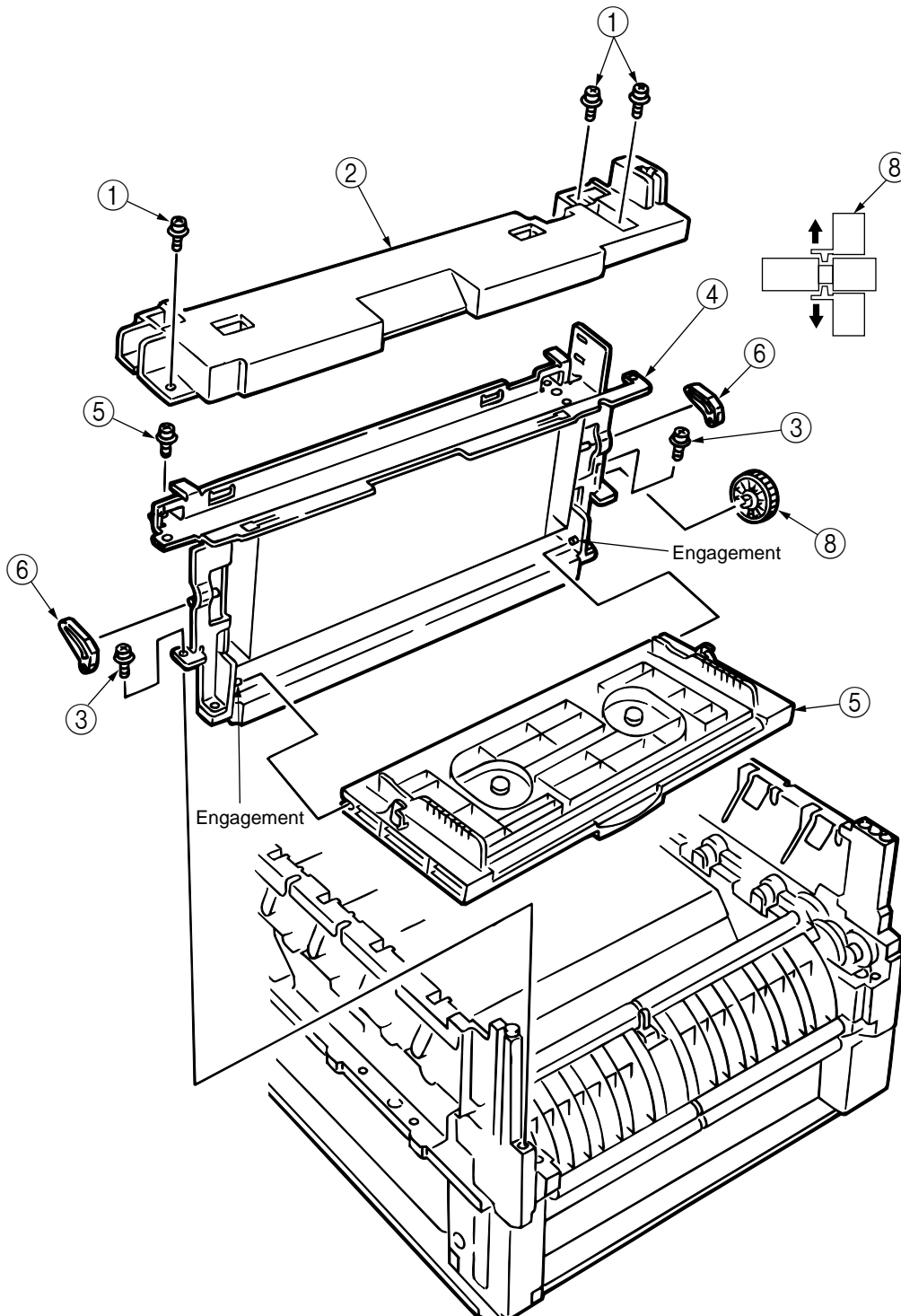

3.3.14 Drum contact Assys

- (1) Insert a flatblade screwdriver between the printer case and the drum contact Assy ① to demount the drum contact Assy.

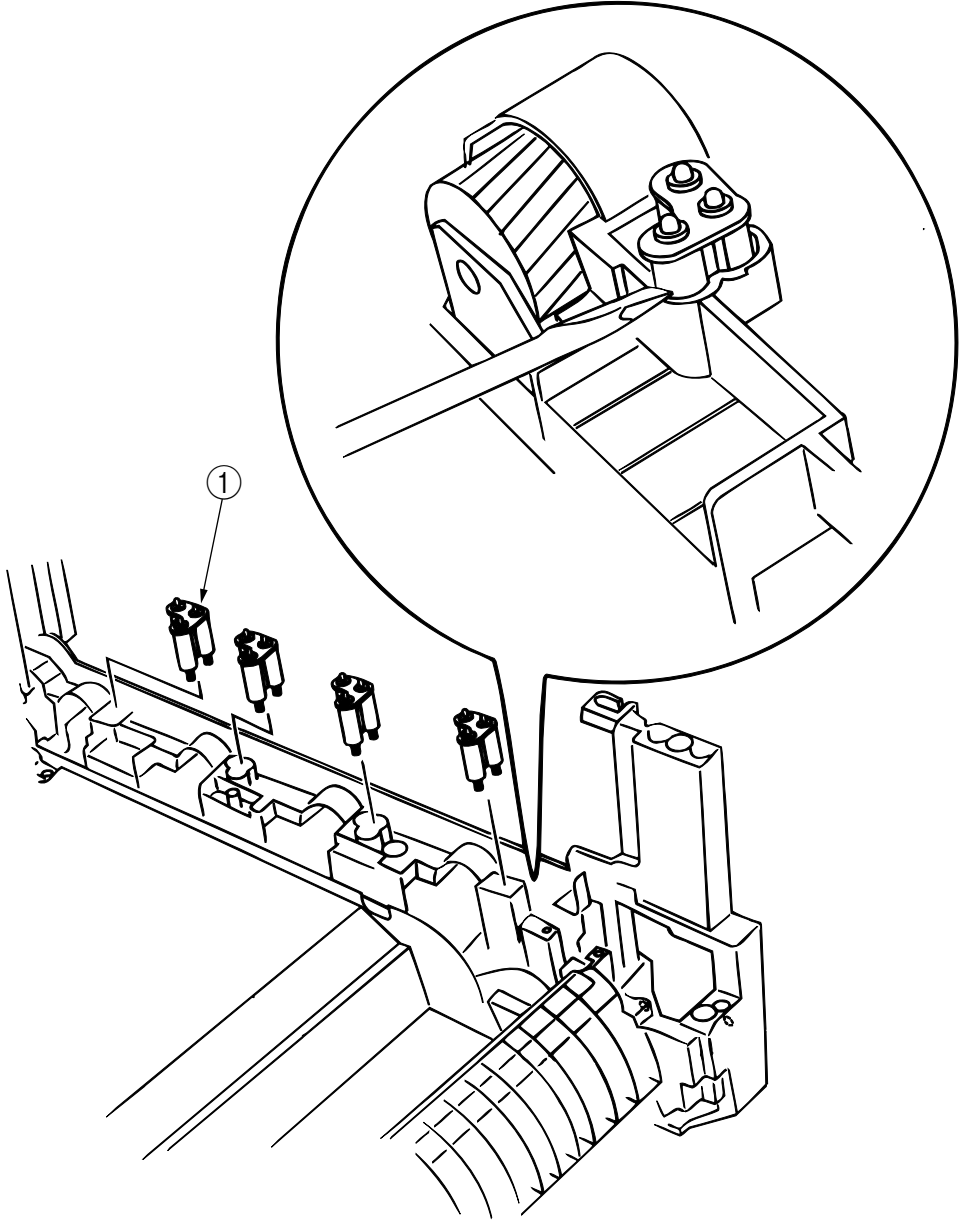

3.3.15 Registration roller Assy (A)/ Registration drive gear (A)

- (1) Remove the front cover (see section 3.3.11).
- (2) Remove the rear cover (see section 3.3.12).
- (3) Remove the multipurpose tray (see section 3.3.13).
- (4) Unscrew the four screws ① to demount the registration roller Assy (A) ②.
- (5) Remove the E ring ③ to detach the registration gear (A) ④.

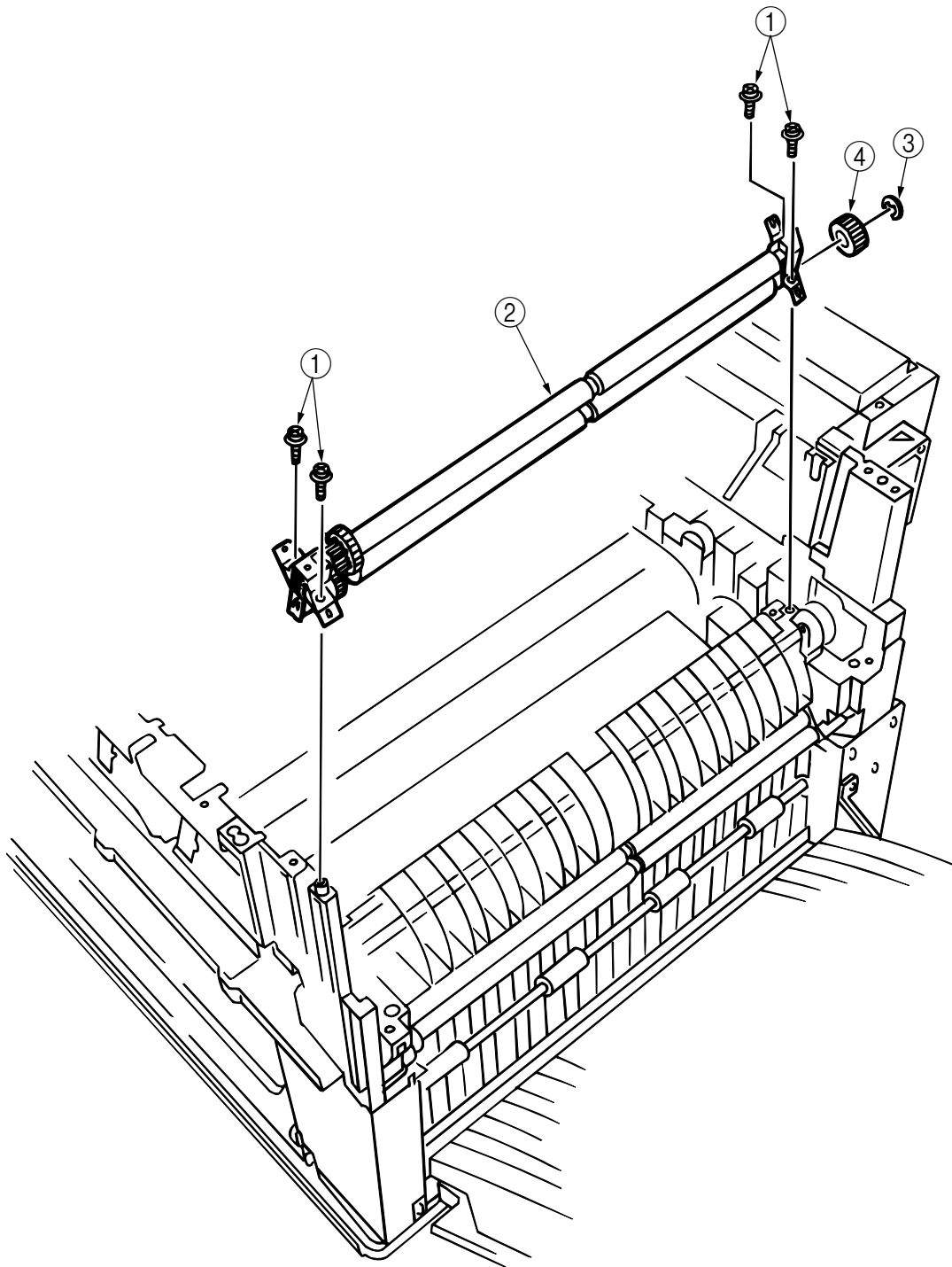

3.3.16 Registration roller Assy (B)

- (1) Remove the cassette Assy.
- (2) Remove the front cover (see section 3.3.11).
- (3) Remove the rear cover (see section 3.3.12).
- (4) Remove the electrical chassis (see section 3.3.21).
- (5) Remove the registration clutch (see section 3.3.17).
- (6) Remove the printer chassis (see section 3.3.23).
- (7) Unscrew the four screws and pull out the registration Assy (B) ② in the arrow direction.

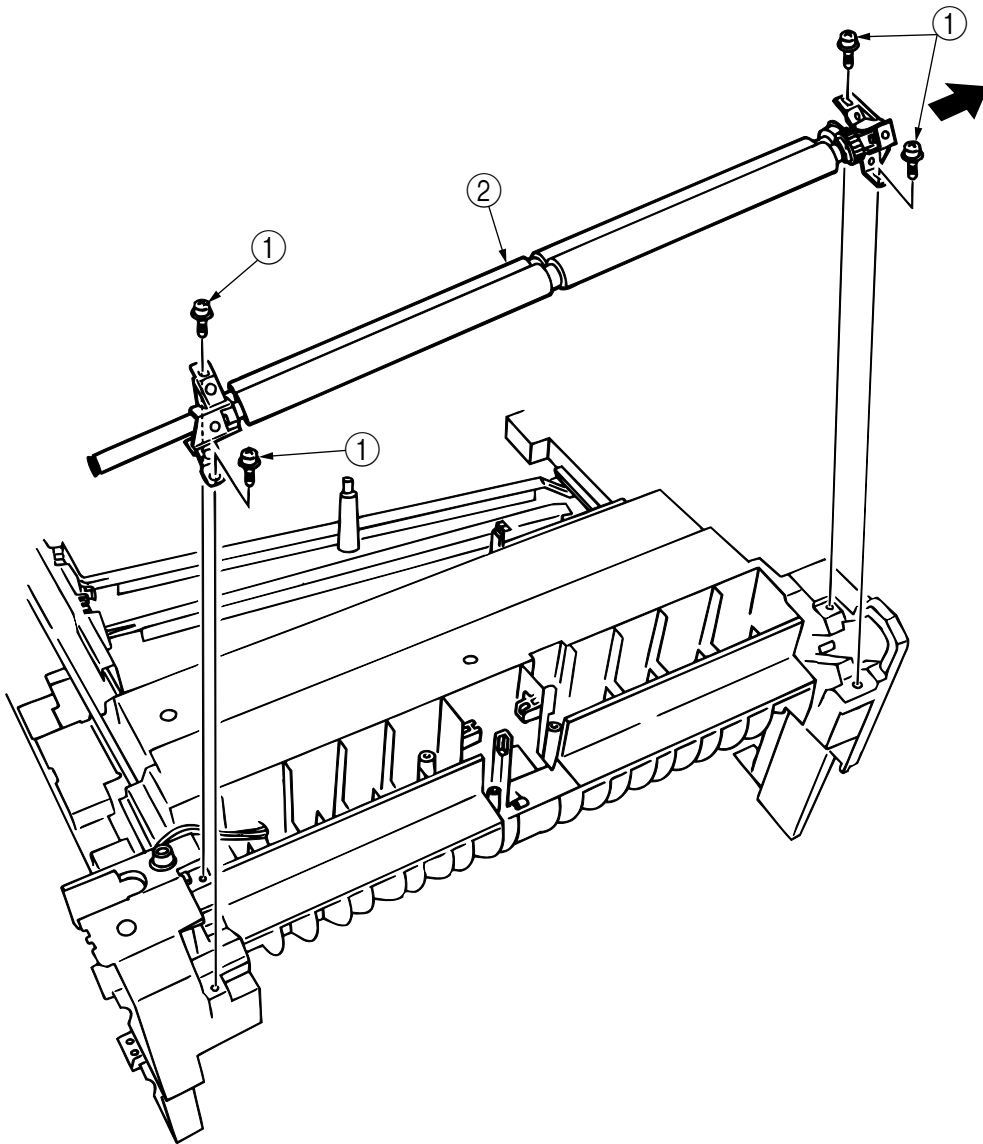

3.3.17 Registration clutch, Registration motor Assy

- (1) Remove the left side cover (see section 3.3.9).
- (2) Remove the electrical chassis (see section 3.3.21).
- (3) Remove the connector and the E ring ①, then screws ③ and ④, and then the earth plate ⑤.
- (4) Remove the connector and unscrew the two screws ⑥ to demount the registration motor Assy ⑦.

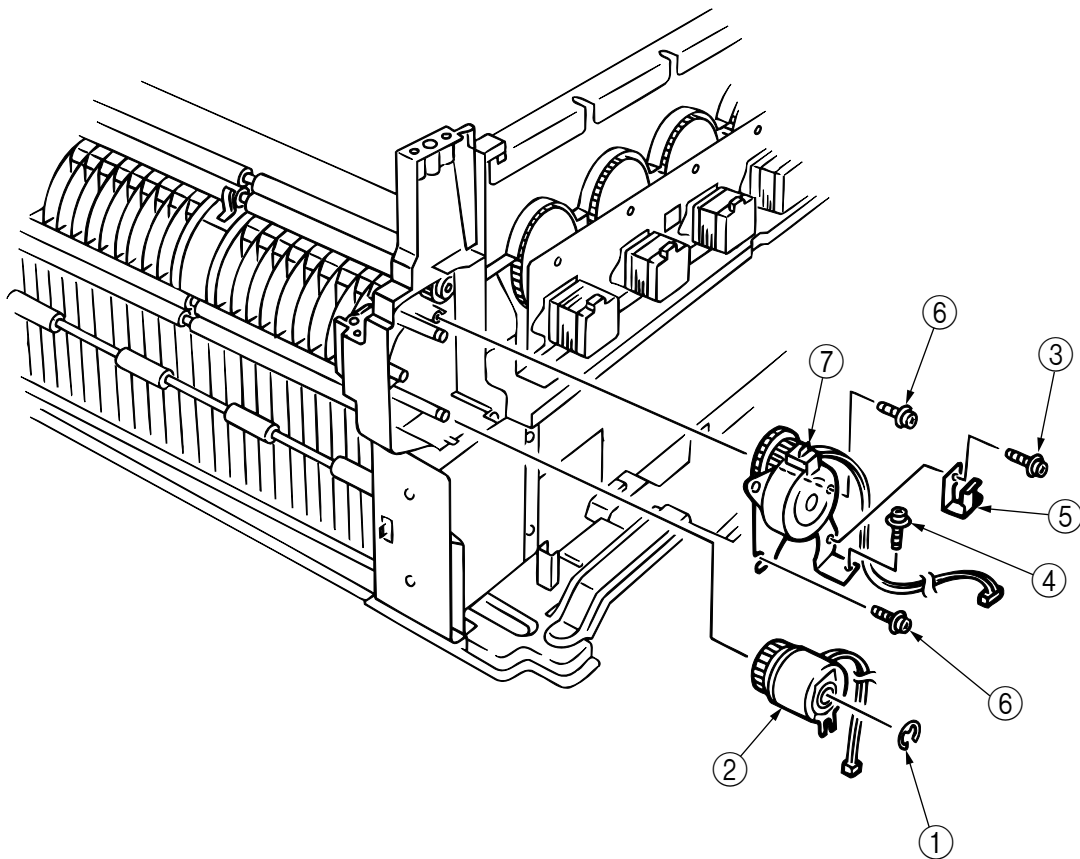

3.3.18 Cooling fan

- (1) Unhook the connector ①, and remove the screws ② and the cooling fan ③.

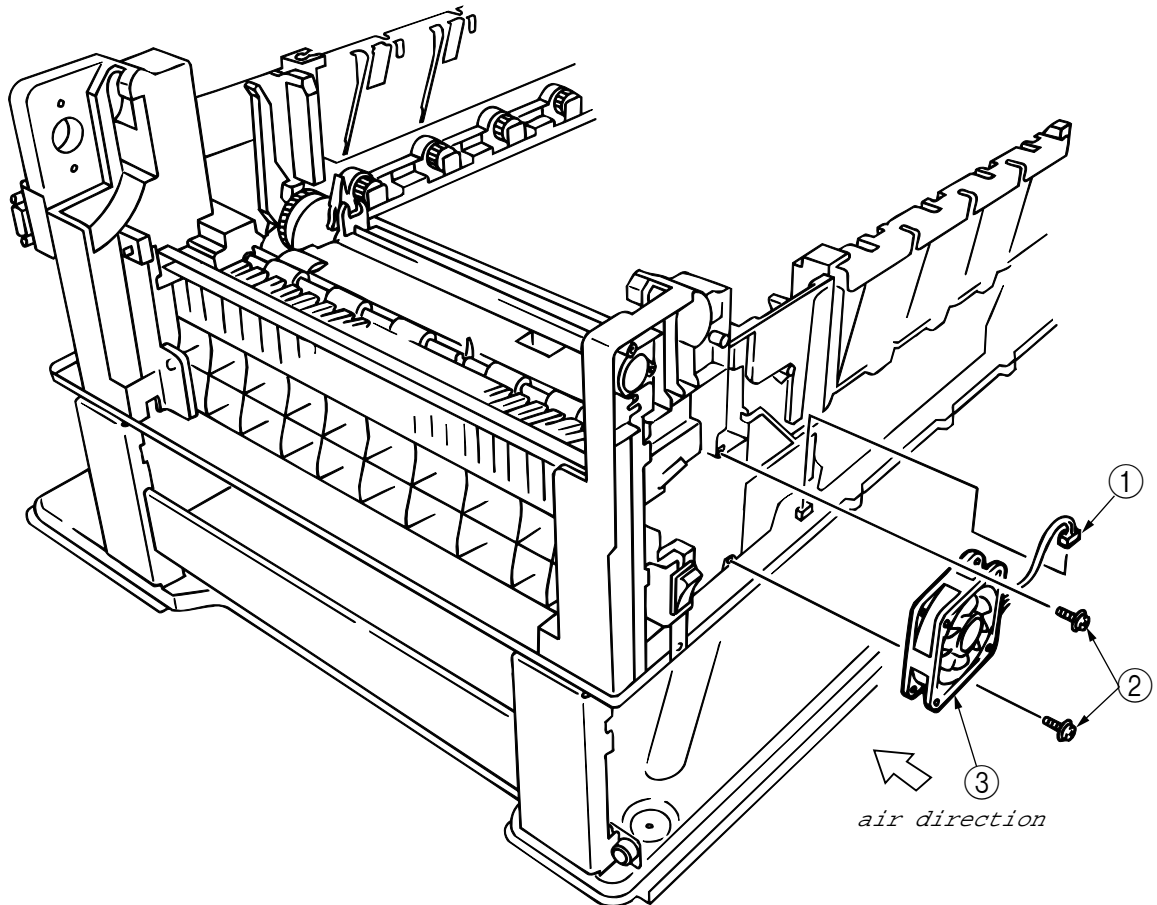

3.3.19 Color registration sensor Assy

- (1) Remove the two screws ① and the three connectors to demount the color registration sensor Assy ②.
- (2) Remove the earth plate B ③.

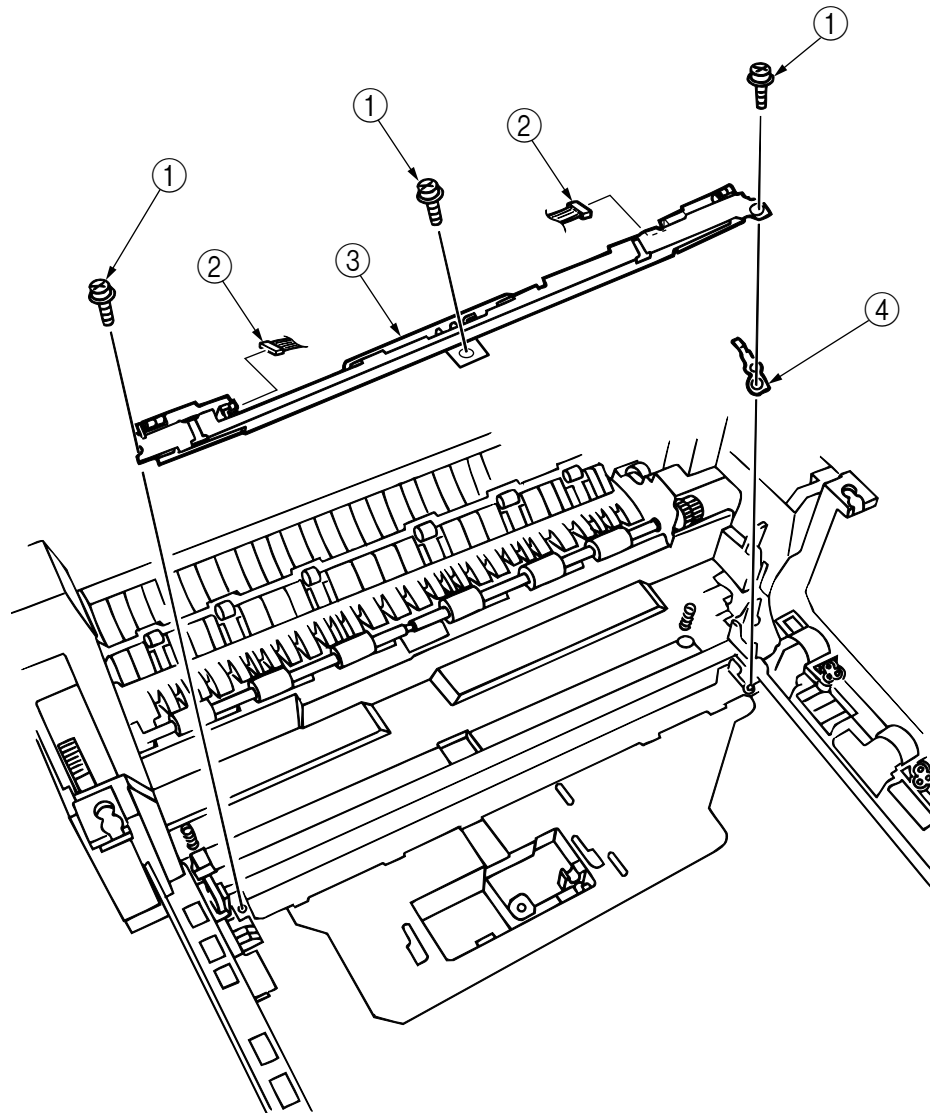

3.3.20 Duplex guide Assy

- (1) Unlatch and demount the duplex guide Assy ①.
- (2) Remove the springs ②.

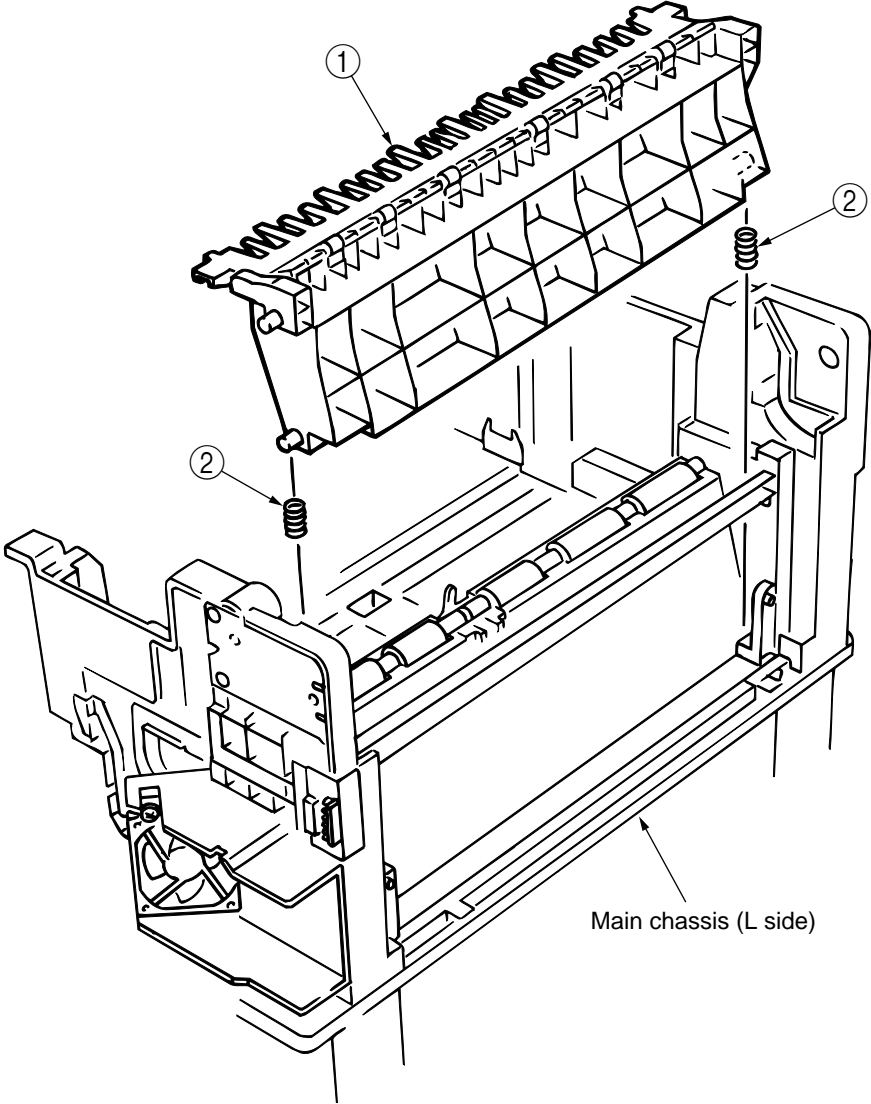

3.3.21 Electrical chassis/ Electrical chassis cooling fan

- (1) Unscrew the five screws ① and two screws ② to remove the plate A ③.
- (2) Unscrew the thirty-one screws ④ to remove the shield plate B ⑤.
- (3) Remove the printer engine controller PWB (see section 3.3.22).
- (4) Unscrew the eleven screws ⑥ to detach the electrical chassis ⑦.
- (5) Unscrew the two screws ⑧ to demount the electrical chassis cooling fan ⑨.

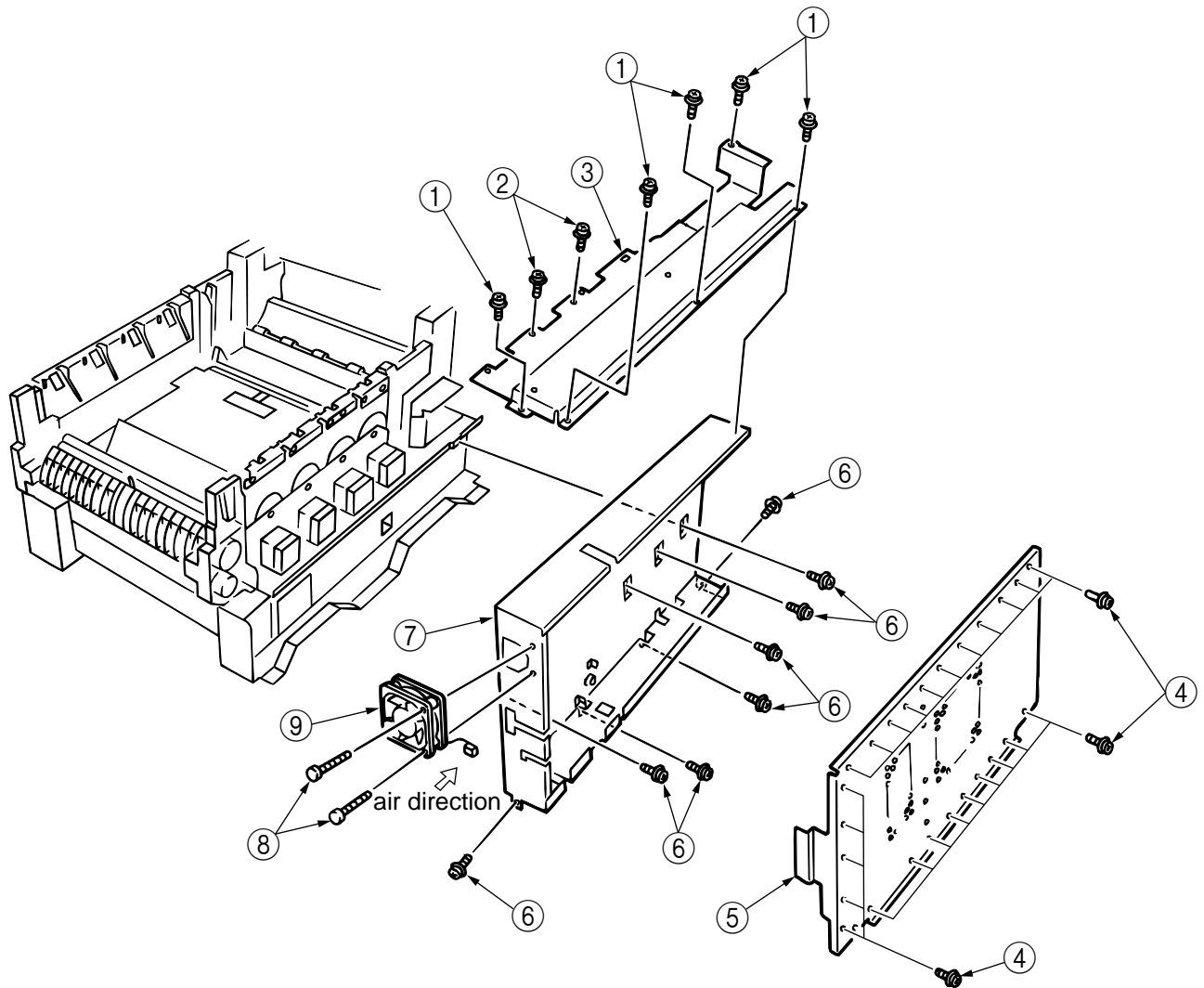

3.3.22 Printer engine controller PWB

- (1) Remove the rear cover (see section 3.3.12).
- (2) Remove the electrical chassis and the electrical cooling fan (see section 3.3.21).
- (3) Remove the five screws ① and all the connectors to demount the printer engine controller PWB ②.

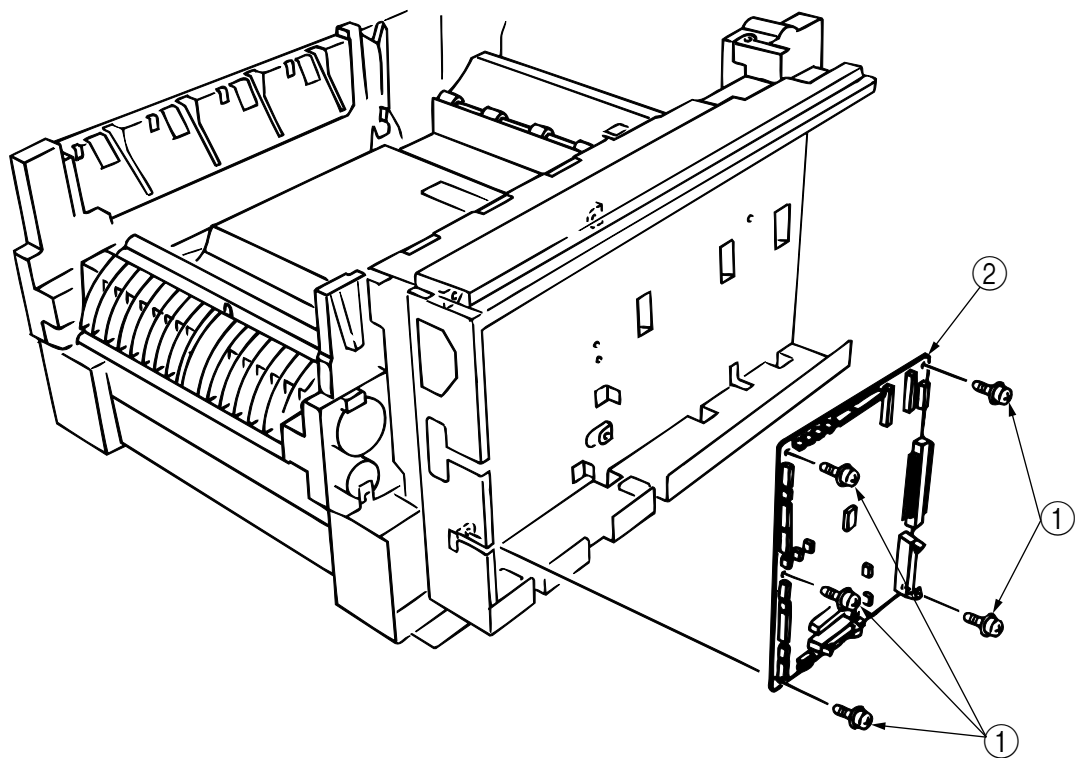

3.3.23 Printer unit chassis

- (1) Unscrew the screw ① and remove the AC switch Assy ②.
- (2) Remove the four black screws ③ and six screws ④ to detach the printer unit chassis ⑤.

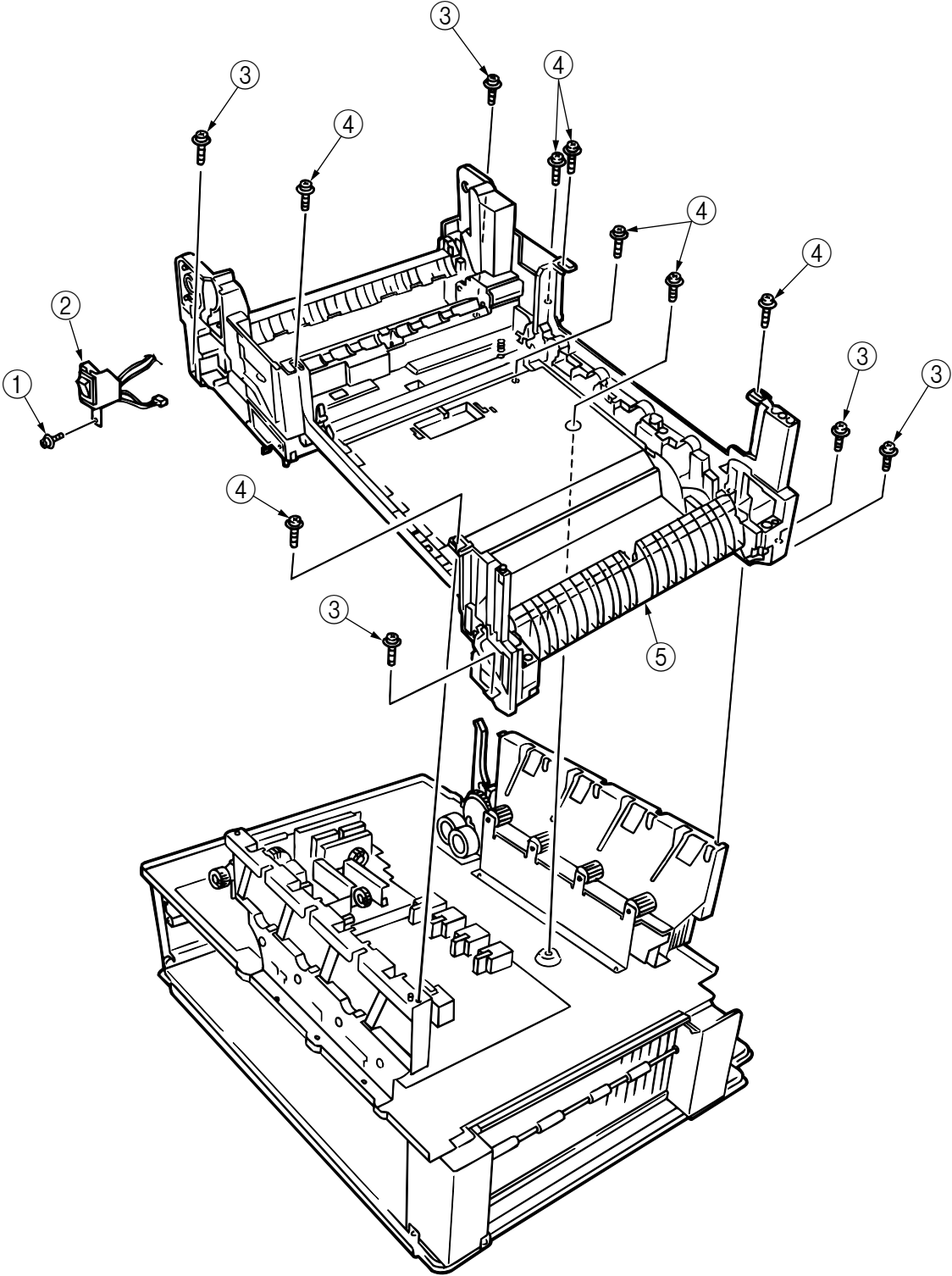

3.3.24 Entrance cassette sensor actuator

- (1) Remove the printer unit chassis (see section 3.3.23).
- (2) Turn over the main chassis.
- (3) Remove the two clamps with tweezers to demount the entrance cassette sensor actuator ①.

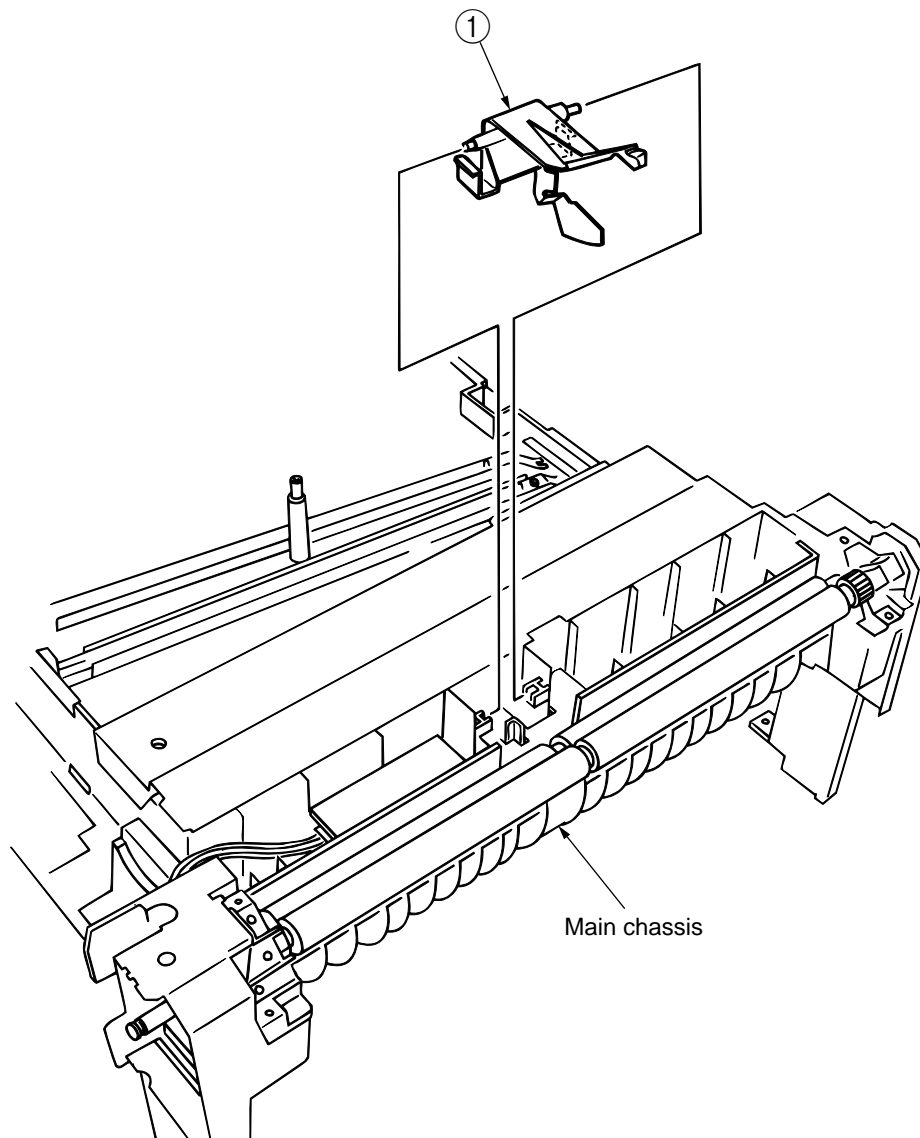

3.3.25 Entrance sensor PWB

- (1) Remove the registration roller Assy (B) (see section 3.3.16).
- (2) Remove the two screws ① to demount the entrance sensor PWB ②.

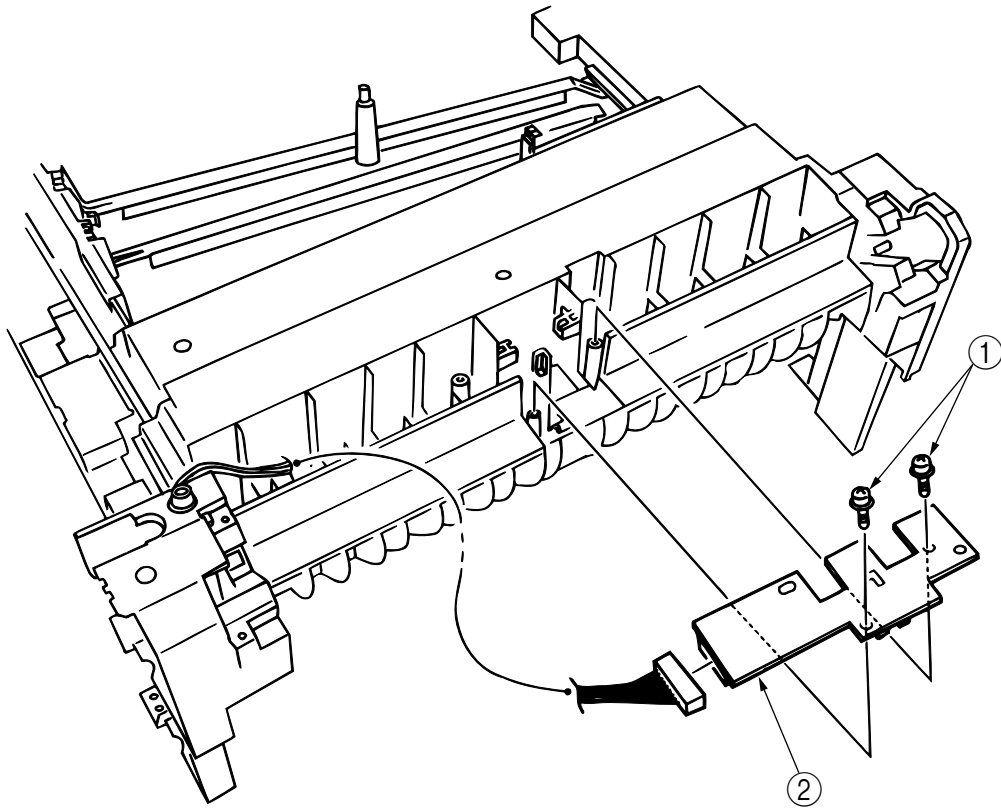

3.3.26 Entrance MT sensor actuator and Entrance belt sensor actuator

- (1) Remove the entrance sensor PWB (R71) (see section 3.3.25).
- (2) Unlatch and detach the entrance MT sensor actuator ①.
- (3) Unlatch and detach the entrance belt actuator ②.

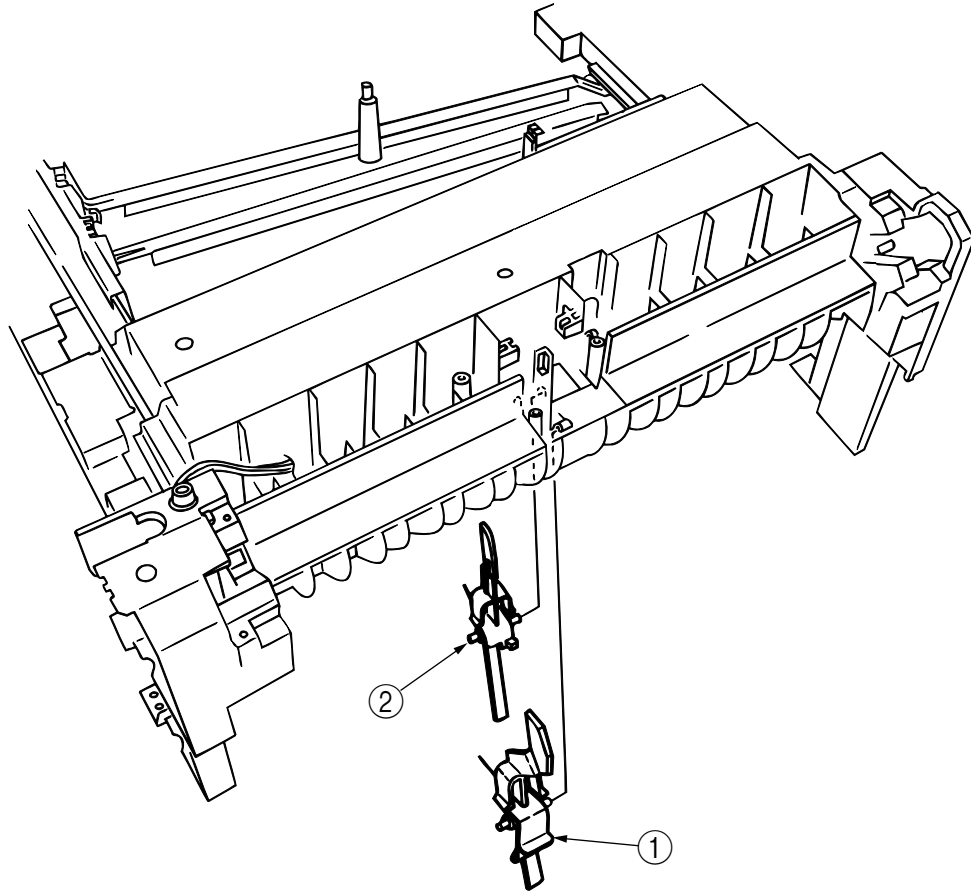

3.3.27 Main motor fan/ Fuser eject roller

- (1) Unscrew the two screws ① to remove the fan Assy ②.
- (2) Unscrew the fuser eject roller contact ④.
- (3) Remove the fuser drive gear ⑤.
- (4) Unscrew the fuser drive gear Assy ⑧.
- (5) Remove the screws and washers ⑩ to demount the fan ⑪.
- (6) Unlatch and detach the fuser eject roller bearing (L) ⑫ and fuser eject roller ⑬.

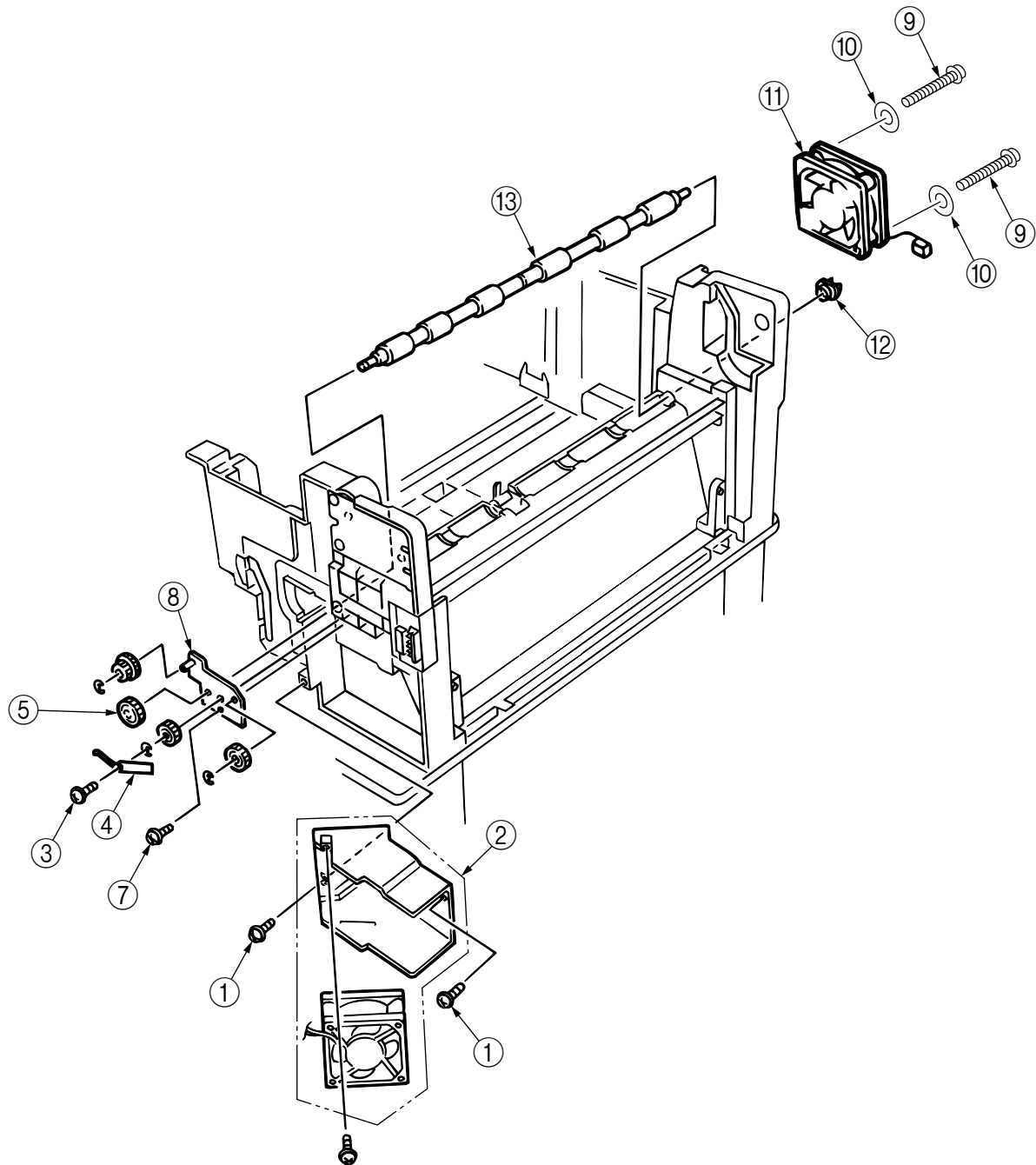

3.3.28 Eject sensor Assy

- (1) Remove the fuser eject roller (see section 3.3.27).
- (2) Remove the screw ① and connector ② to demount the (red/blue) eject sensor Assy ②.

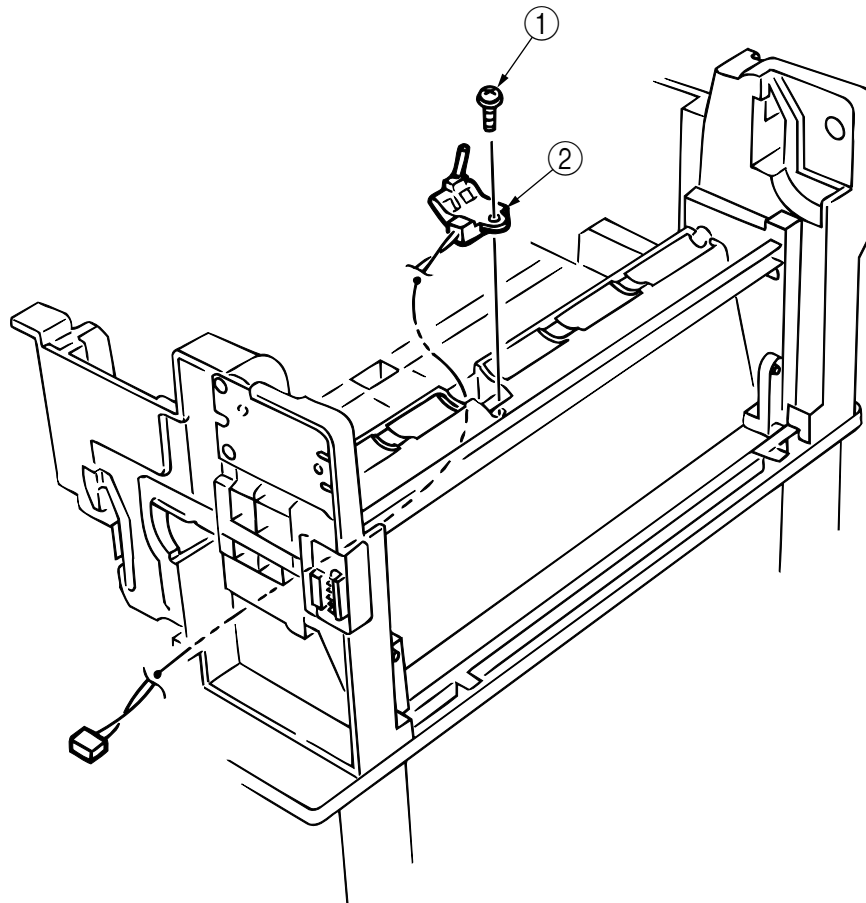

3.3.29 Fuser latching handle (L)

- (1) Remove the latching handle spring ①.
- (2) Unscrew the fuser latching handle (L) ③.

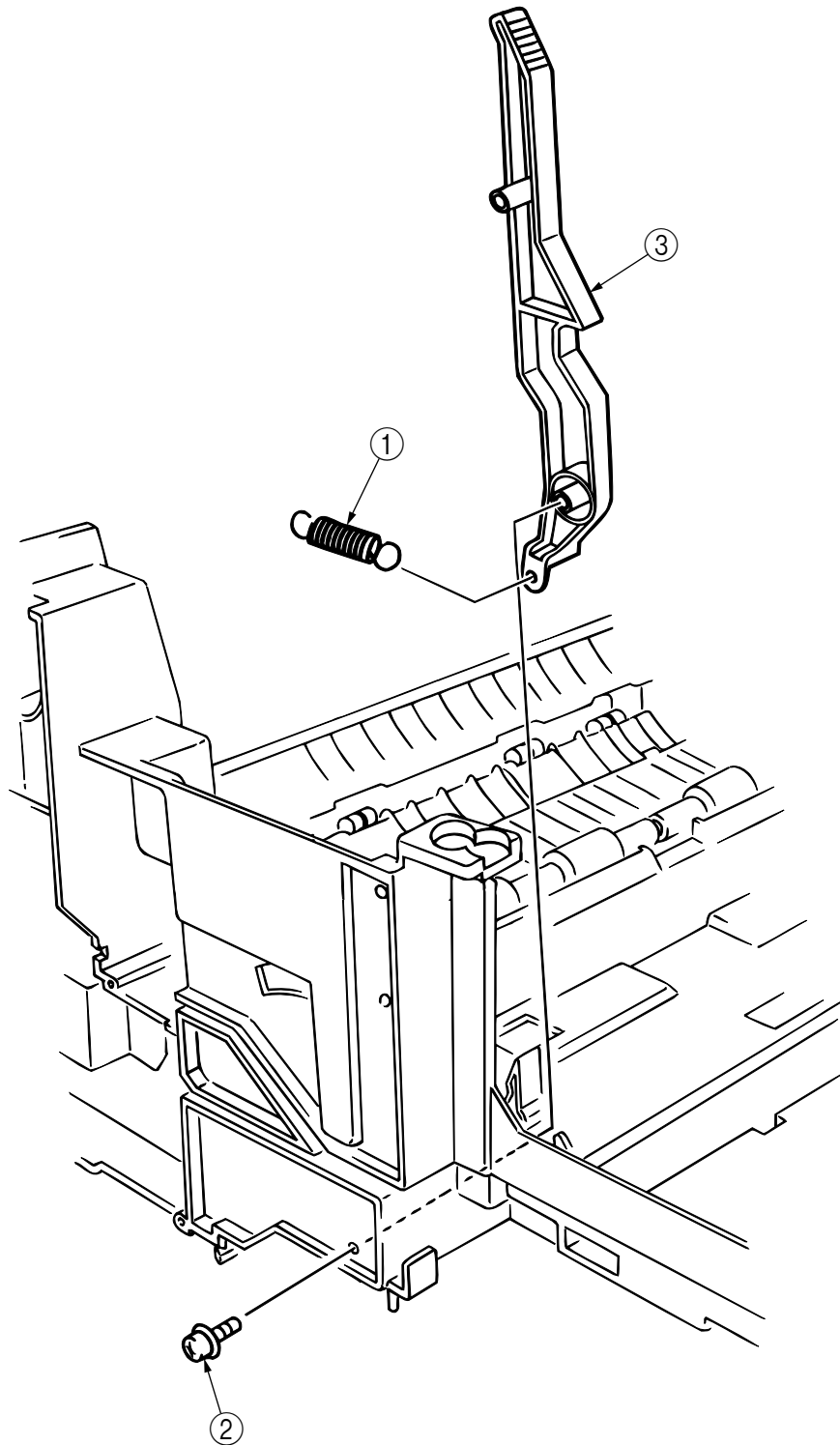

3.3.30 Belt motor Assy

- (1) Remove the fuser latching handle (R) (see section 3.3.32).
- (2) Unscrew the two screws ① to detach the two connector ②.
- (3) Demount the belt motor Assy ③.

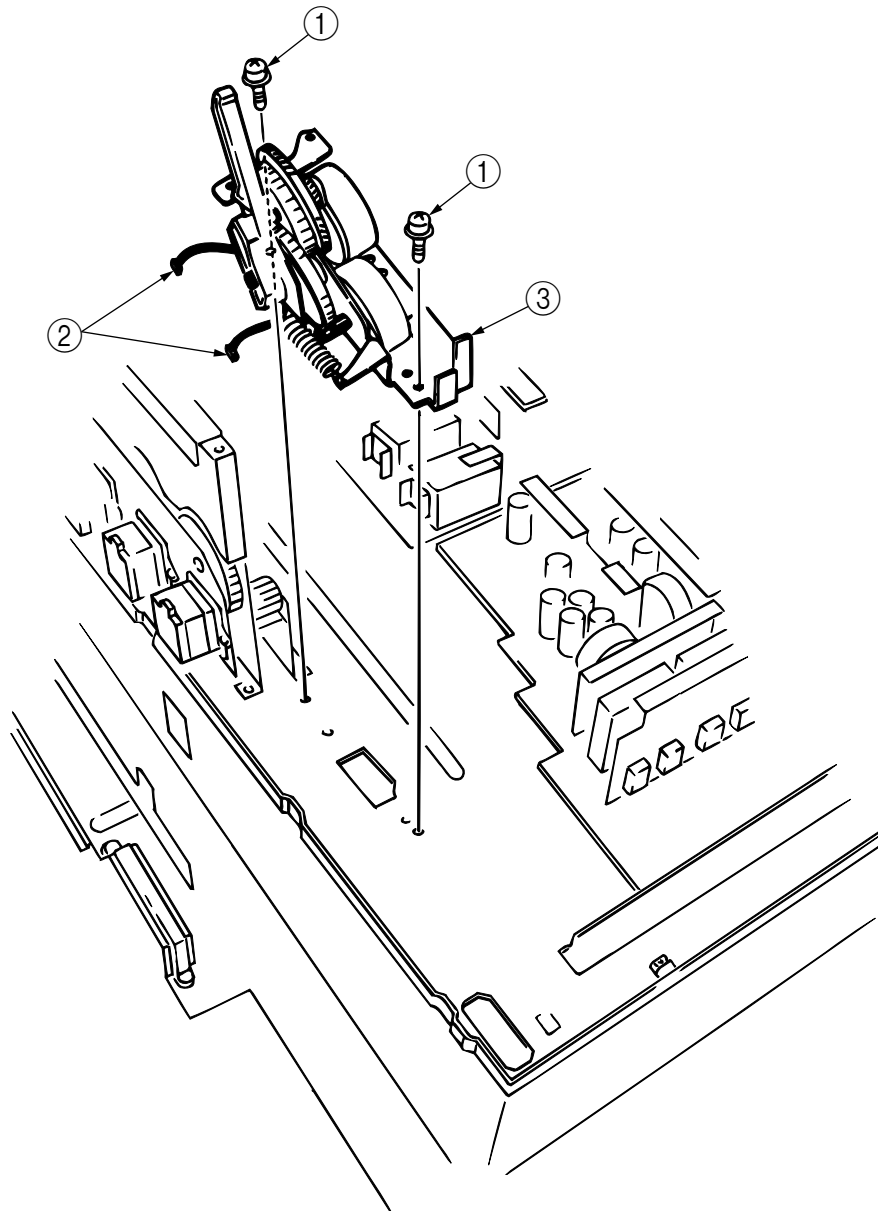

3.3.31 Fuser latching handle (R)

- (1) Remove the printer unit chassis (see section 3.3.23).
- (2) Remove the E ring ①.
- (3) Remove the fuser latching handle spring ② to detach the fuser latching handle (R) ③.

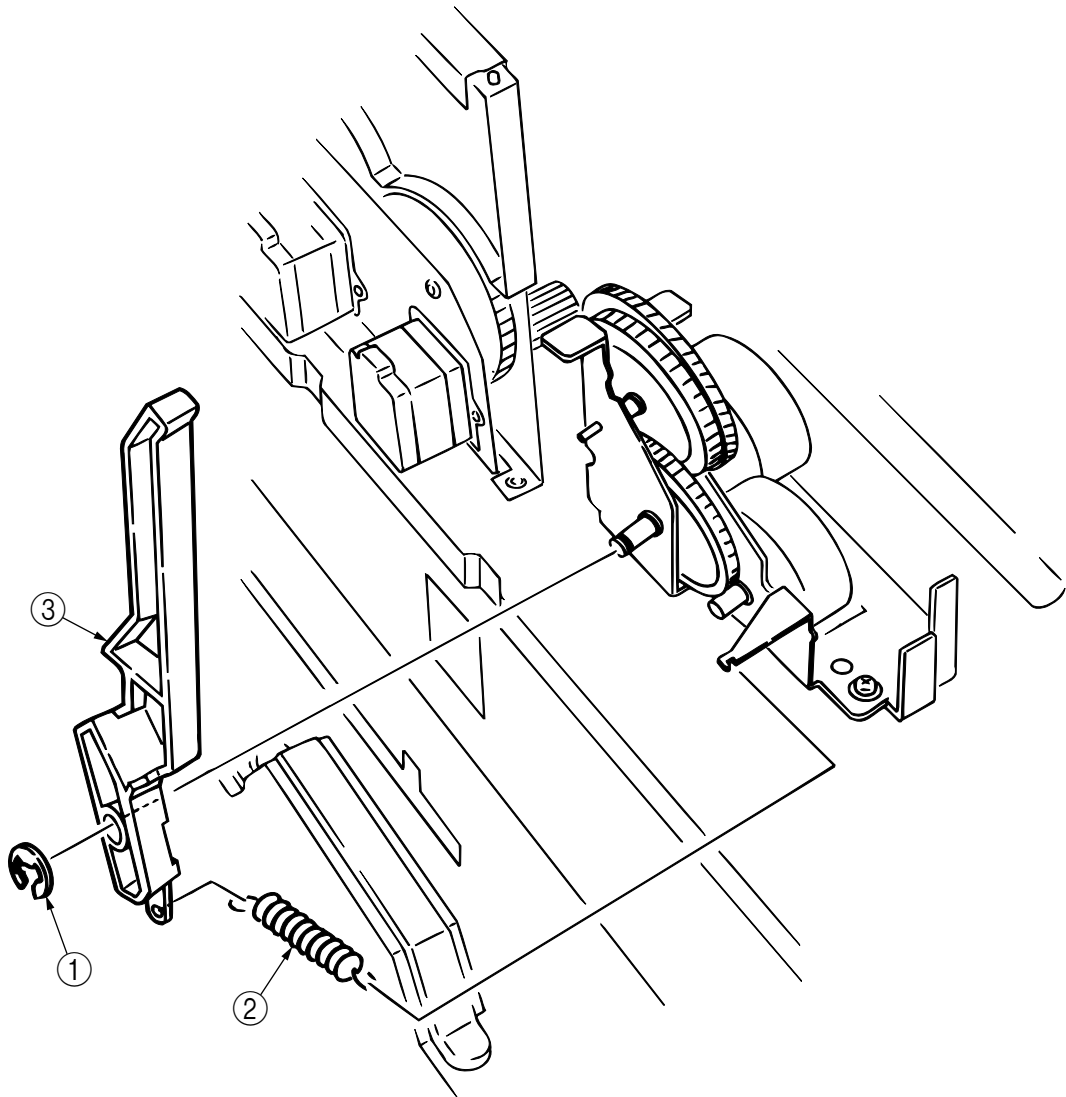

3.3.32 Main motor Assy

- (1) Remove the belt motor Assy (see section 3.3.30).
- (2) Remove all the connectors.
- (3) Remove the two screws ① to demount the main motor Assy ②.

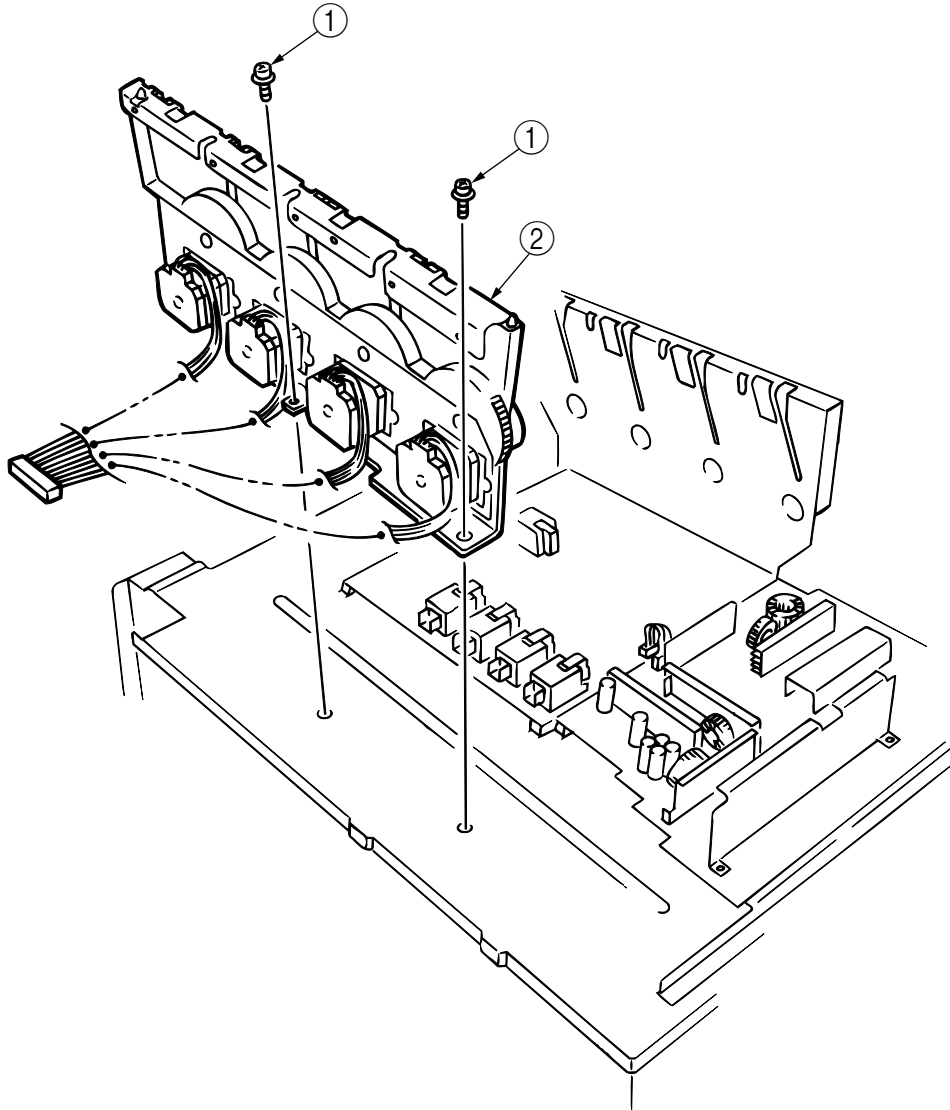

3.3.33 Contact Assy/ Side plate Assy

- (1) Remove the printer unit chassis (see section 3.3.23).
- (2) Remove the four screws ① to detach the side plate Assy ②.
- (3) Remove the three screws ③ to detach the contact Assy ④.

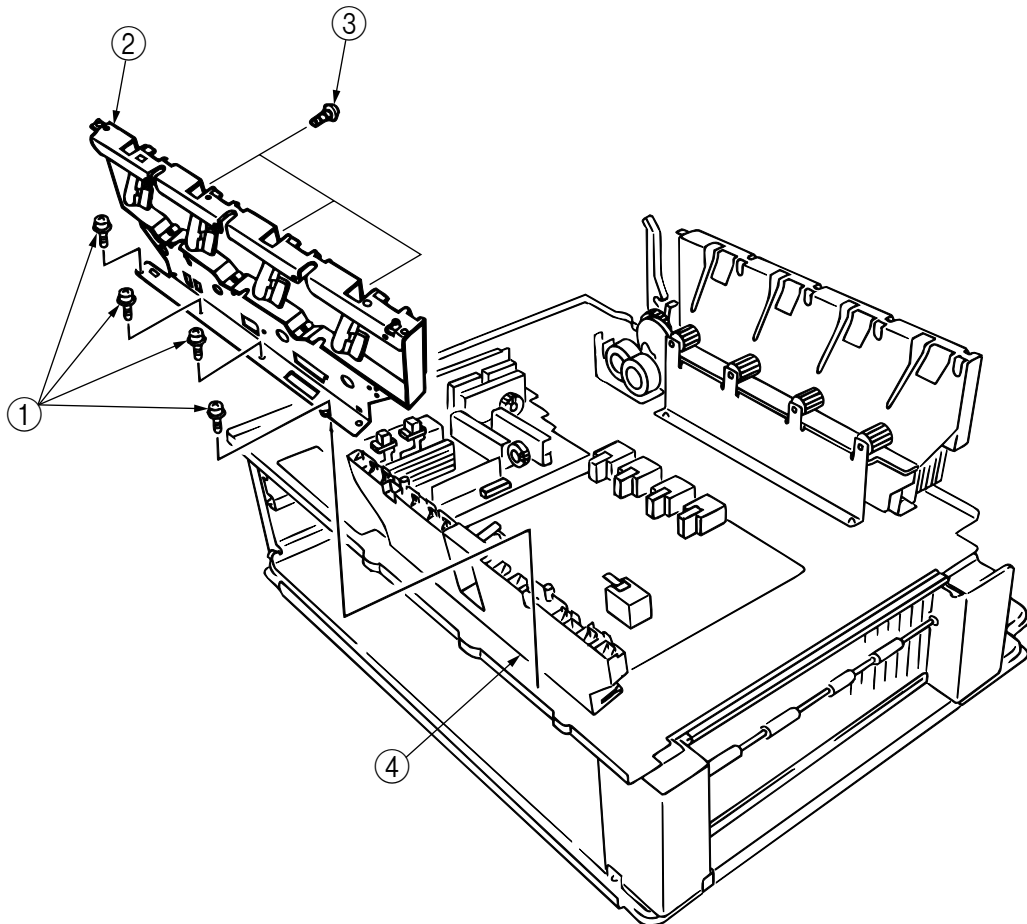

3.3.34 Low voltage power supply

- (1) Remove the printer unit chassis (see section 3.3.23).
- (2) Unhook the connector ①.
- (3) Remove the eight screws ② to demount the low voltage power supply ⑤.

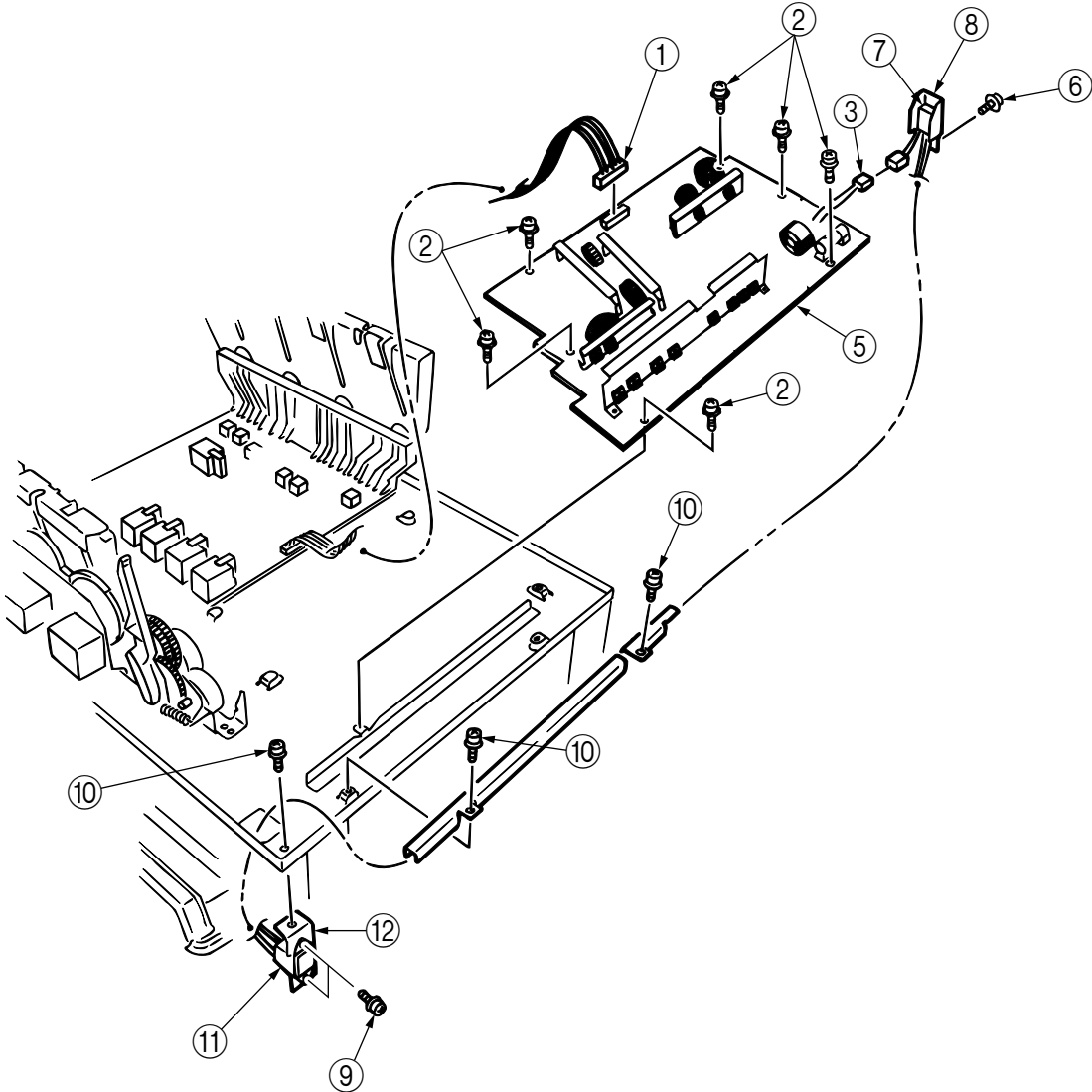

3.3.35 High voltage power supply

- (1) Remove the contact Assy (see section 3.3.33).
- (2) Unhook the connector of the high voltage power supply ②.
- (3) Remove the two screws ① to detach the high voltage power supply ② and the tape harness ③.

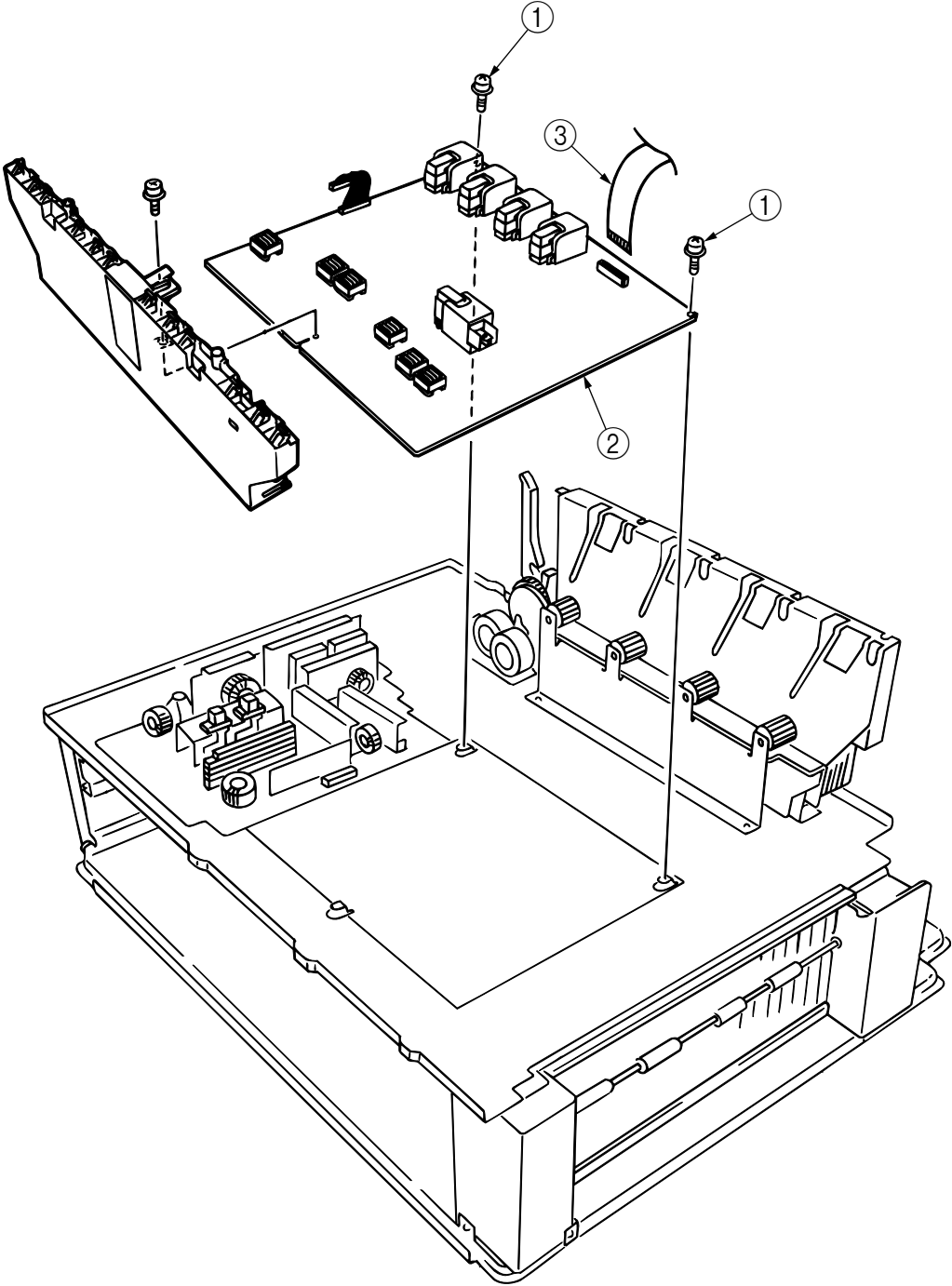

3.3.36 Main feed Assy

- (1) Remove the printer unit chassis (see section 3.3.23).
- (2) Remove the low voltage power supply and high voltage power supply (see sections 3.3.34 and 3.3.35).
- (3) Unscrew the five screws ① to remove the lower plate ②.
- (4) Unscrew the six screws ③ to demount the main feed Assy ④.
- (5) Unscrew the screws ⑤ to detach the cable and then the PCB size board ⑥.
- (6) Unscrew the screw ⑦ to detach the duplex connector ⑧.
- (7) Unscrew the screws ⑨ to detach the second tray connector ⑩.

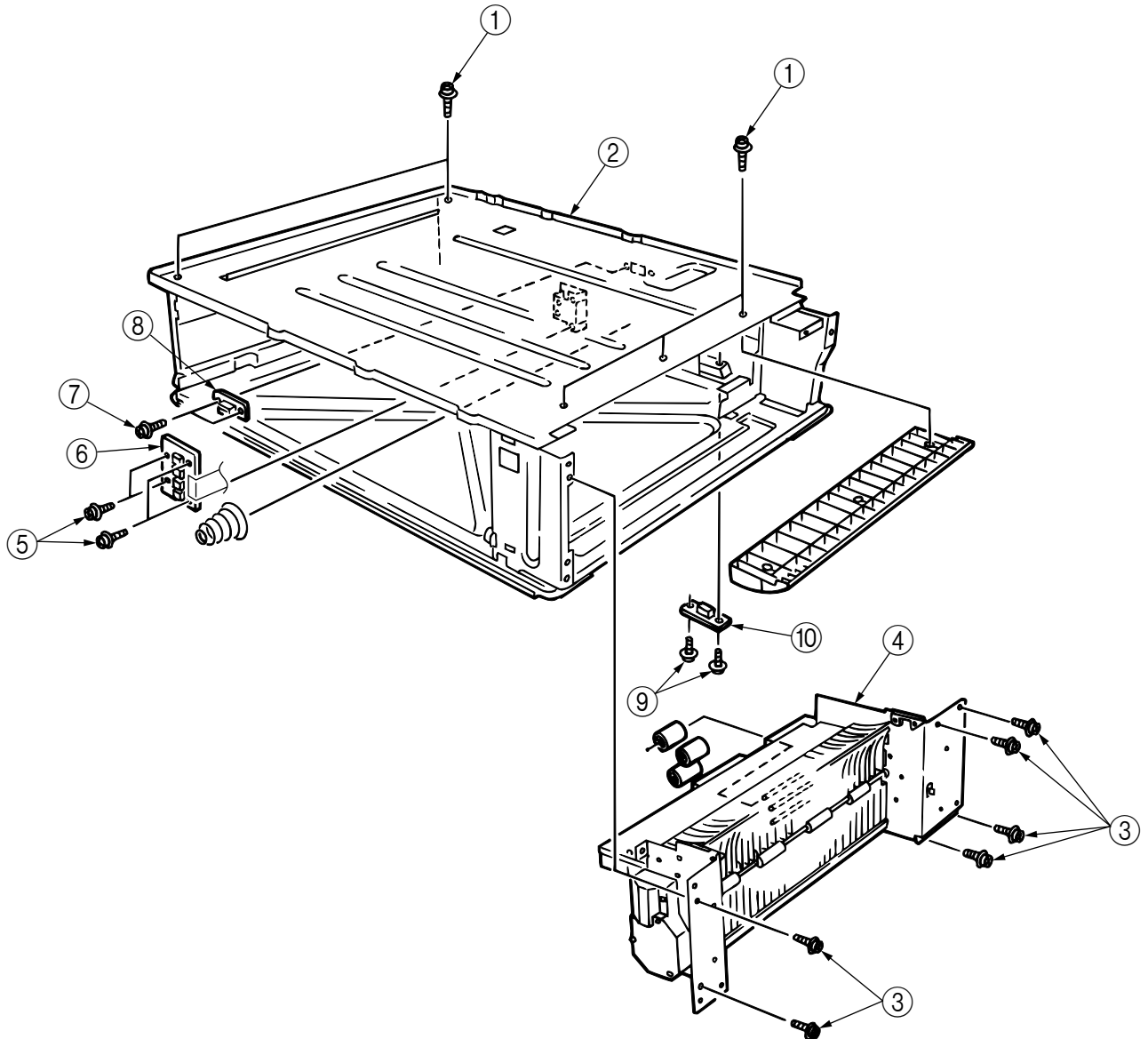

3.3.37 Fuser unit

- (1) Open the top cover ①.
- (2) Push the right and left fuser levers (blue) ② in the arrow direction to detach the fuser unit ③.

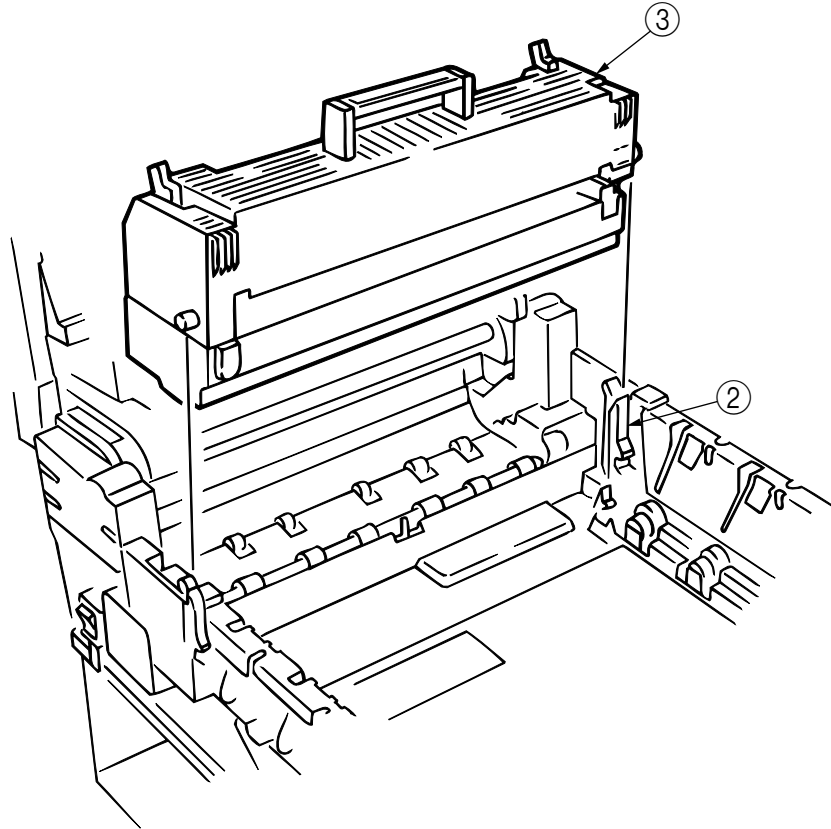

3.3.38 Belt unit

- (1) Open the top cover ①.
- (2) Remove the I/D unit.
- (3) Push the lever (blue) ② in the arrow direction, raise the handle (blue) and detach the belt unit ③.

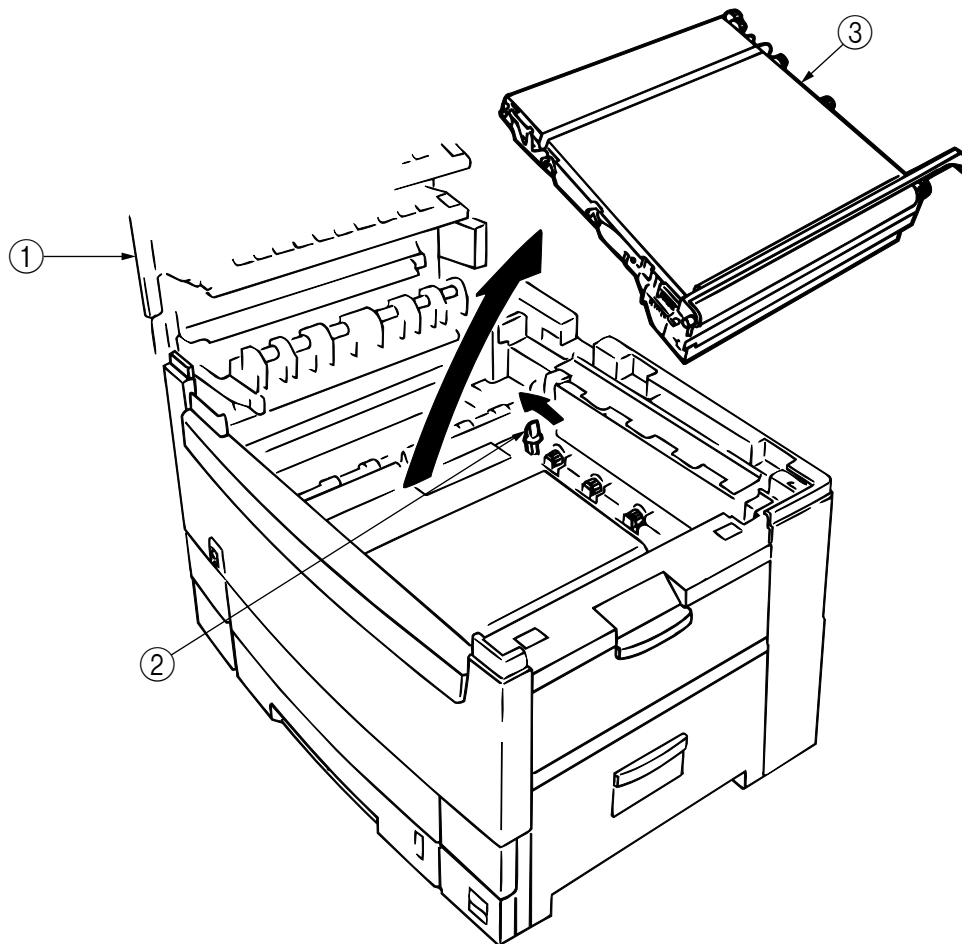

3.3.39 Duplex unit

- (1) Remove the cassette Assy, the front cover and the front cover inner buffle.
- (2) Unlatch the rear at the right and left and pull the duplex unit ① toward the front.

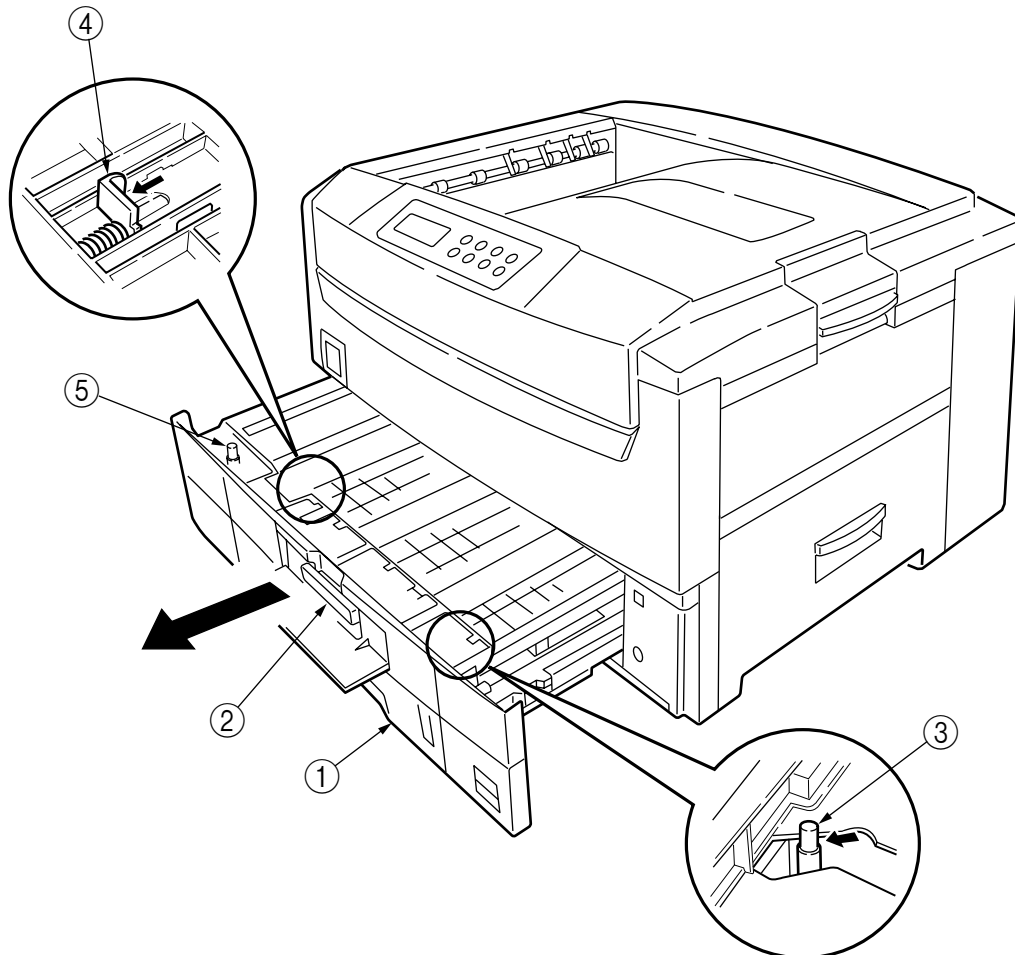

3.3.40 CU Assy

(1) Pulling out Control Board

1. Loosen the two screws ①.
2. Pull the control board ② out.
3. Place the control board ② on a flat table.

(2) Detaching Fan

1. Remove the connector ③.
2. Remove the two screws ④.
3. Detach the fan ⑤.

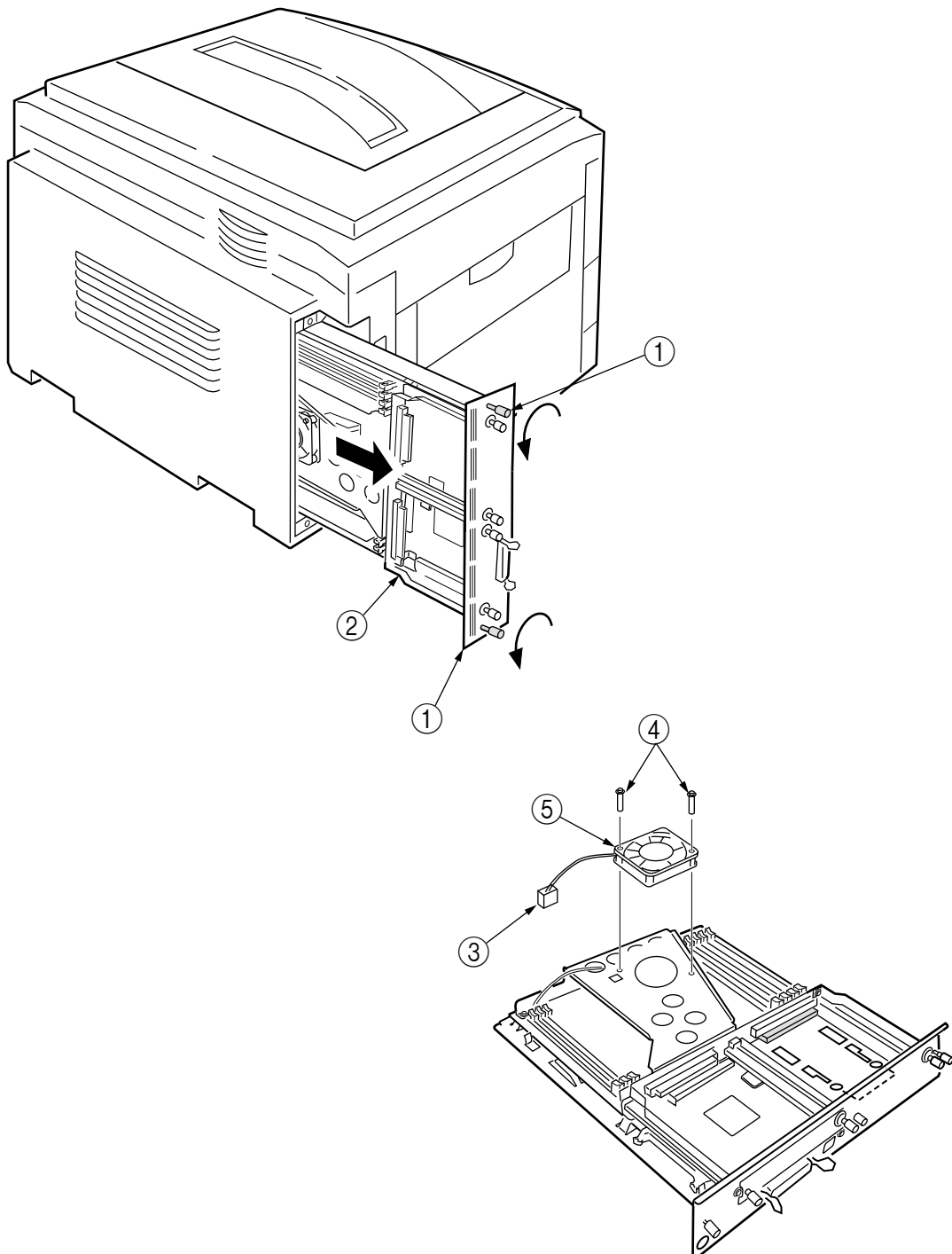

(3) Demounting CRM Board

1. Remove the three screws ⑥ to detach the fan bracket ⑦.
2. Remove the four screws ⑧ to detach the plate support ⑨ and the guide rail ⑩.
3. Remove the two screws ⑪ to detach the guide rail ⑫.
4. Remove the two screws ⑬ and three screws ⑭, then demount the CRM board ⑮.

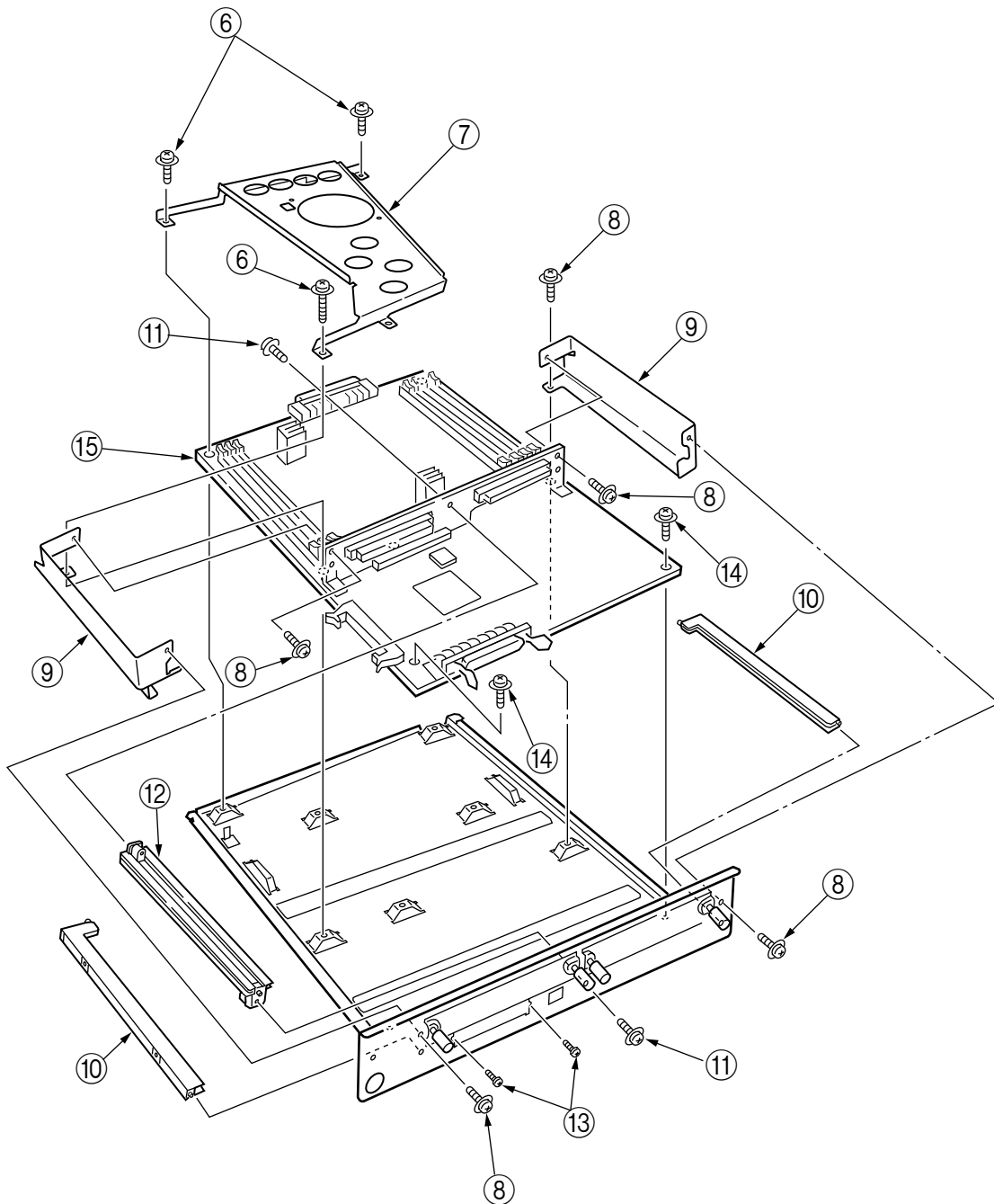

4. ADJUSTMENT

Adjustments are carried out by key operations on the operator panel.

The maintenance menu is included in the general menu of this printer. Choose the maintenance menu for adjustment.

4.1 Maintenance Menu and Its Functions

The general menu has the category, MAINTENANCE MENU.

The items adjustable in this menu are shown below.

Maintenance Menu

Category	Item(1st Line)	Value(2nd Line)	DF	Functions
MAINTENANCE MENU	Power Save Mode	Enabled Disabled	*	Sets the Power Save Mode enabled/disabled. The shift time to enable the Power Save mode can be changed according to the POWER SAVE SHIFT TIME item of SYSTEM CONFIG MENU.
	Normal Paper Black Setting	0 +1 +2 -2 -1	*	Implements fine adjustment of BLACK printing on normal paper when unclear characters or spots are often found on print results. With dispersed or snowed printing in the part at high-density, decrease the value. With unclear printing, increase the value.
	Normal Paper Color Setting	0 +1 +2 -2 -1	*	Implements fine adjustment of COLOR printing on normal paper when unclear characters or spots are often found on the print result. With dispersed or snowed printing in the part at high-density, decrease the value. With unclear printing, increase the value.
	Transparency Black Setting	0 +1 +2 -2 -1	*	Implements fine adjustment of BLACK printing on Transparency when unclear characters or spots are often found on the print result. With dispersed or snowed printing in the part at high-density, decrease the value. With unclear printing, increase the value.
	Transparency Color Setting	0 +1 +2 -2 -1	*	Implements fine adjustment of COLOR printing on Transparency when unclear characters or spots are often found on the print result. With dispersed or snowed printing in the part at high-density, decrease the value. With unclear printing, increase the value.

4.2 Short Plug Settings

The CRM board has five short plugs that can be set as follows:

Short Plug (WE1,3, 5 and 7)

Sets flash ROM DIMM to connect WE signals.

(1-2 Short: Disconnects WE signals; 2-3 Short: Connects WE signals.)

The factory-shipped short plug is set to the 2-3 short: Re-programmable the Flash ROM DIMM.

Short Plug (DIMM2)

Sets the banks of ROM DIMM Slot B.

(1-2 Short: For 1-Bank DIMM; 2-3 Short: For 2-Bank DIMM)

1-bank DIMM (dual-sided 1 bank) is only a prototype and does not exist in production-run printers.

4.3 Printing Singly Using Controller-Equipped Printer

Menu Map Printing

Prints the program versions, controller block, and other printer configuration and settings.

Operation: (Press of Switch)

Without HDD: "0" → "3" → "3"

With HDD: "0" → "0" → "3" → "3"

File List Printing

Prints a list of files stored on a HDD or in ROM.

Operation: (Press of Switch)

Without HDD: "0" → "3" → "1" → "3"

With HDD: "0" → "0" → "3" → "1" → "3"

Font List Printing (PCL)

Prints a list of PCL fonts.

Operation: (Press of Switch)

Without HDD: "0" → "3" → "1" → "1" → "3"

With HDD: "0" → "0" → "3" → "1" → "1" → "3"

Font List Printing (PS)

Prints a list of PS fonts.

Operation: (Press of Switch)

Without HDD: "0" → "3" → "1" → "1" → "1" → "3"

With HDD: "0" → "0" → "3" → "1" → "1" → "1" → "3"

Demo Printing

Prints the demo patterns for destinations.

Operation: (Press of Switch)

Without HDD: "0" → "3" → "1" → "1" → "1" → "1" → "3"

With HDD: "0" → "0" → "3" → "1" → "1" → "1" → "1" → "3"

Ethernet Board Self-Diagnostic Printing

When equipped with an Ethernet board, the printer runs diagnostic checks on itself by holding the SW on the Ethernet board down for two seconds or more, and prints the results.

4.4 Adjustment after Part Replacement

Adjustment to be implemented after each part replacement is described below.
Adjustment and correction of color registration are always required for each part replacement.

Replaced Part	<i>Adjustment</i>
LED Head	Color balance adjustment
Drum Cartridge (Y, M, C, K)	Not required.
Fuser Unit	Not required.
Belt Cassette Assy	Not required.
PU (K73 Board)	Re-mounting the EEPROM used prior to the replacement *Note

*Note: When the EEPROM of the PU (K73 Board) is replaced to a new one, color balance must be adjusted.

4.5 Color Balance Adjustment

Color balance has been adjusted appropriately when a printer is shipped from the plant. However, it may be out of the appropriate balance during use. In such a case, color balance should be modified.

Note: Density of each color depends on each other. Therefore, adjustment must be repeated several times to reach the correct color balance.

- (1) Set letter paper in the tray specified on the operator panel.
- (2) Press **③** several times to display [COLOR MENU].
- (3) Press **①** or **⑤** to display [COLOR BALANCE CORRECTION/PATTERN PRINT].
- (4) Press **③** to start test printing.
- (5) Press **①** to display [COLOR BALANCE CORRECTION/RESET].
- (6) Choose the number of the color closest to the [(] part on the test pattern.
If the selected color is [00], the color balance is correct and no adjustment is required.
If it is not [00], the color balance should be adjusted in the procedures below.
- (7) Press **②** or **⑥** several times to display the value selected in Step (6).
- (8) Press **③** to start test printing.
- (9) Repeat the steps (6)~(8) to approximate the color at the [(] part on the test pattern to [00] as much as possible.
- (10) Press **④** to display [ON LINE].

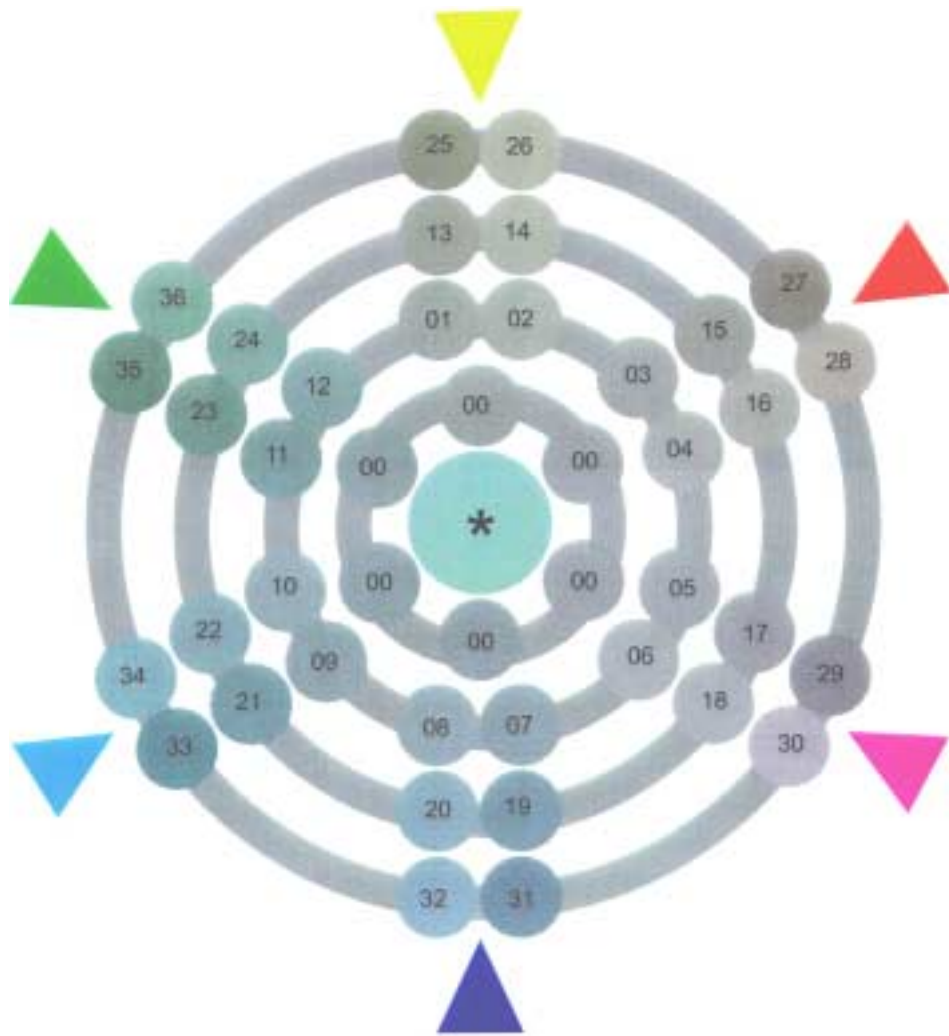

4.6 EEPROM Replacement after CRM Board and K73 Board Replacement

When replacing the CRM Board or K73 Board, the EEPROM must be removed and re-mounted on the new board (to deliver the user setting and font installation information to the new board).

If the EEPROM used by the user is broken and not suitable for further use, the EEPROM on the new board may be used.

5. REGULAR MAINTENANCE

5.1 Consumables to be Regularly Replaced

It is recommended that a user should replace the consumables below according to the replacement standard. (If not replaced, print quality is not assured or it may result in a failure.)

Part Name	Time for Replacement	Replacement Condition	Adjustment after Replacement
Large-capacity Toner Cartridge	When the message "Toner Low" is displayed.	After 15,000 copies have been printed.	Replace the Toner cartridge.
ID Cartridge	When the message "Drum Life" is displayed.	After 26,000 copies have been printed. (at 3P/J)	Reset the drum counter after drum replacement.
Fuser Unit	When the message "Fuser Life" is displayed.	After 80,000 copies have been printed.	Reset the fuser counter.
Belt Unit	When the message "Belt Life" is displayed.	After 80,000 copies have been printed. (at 3P/J)	Reset the belt counter.

The above consumables replacement may be performed by a user.

5.2 Cleaning

The inside and outside of this printer should be cleaned with a hand vacuum cleaner, if necessary.

Note: Do not touch the Image drum terminal, LED lens array and LED head connectors.

5.3 Cleaning of LED Lens Array

When a longitudinal white band or stripes (that is, void or light printing) appear on a printed paper surface, the LED lens array should be cleaned.

Note: The LED head cleaner must be used to clean the LED lens array. (The LED head cleaner is included in the Toner cartridge box.)

White band, white stripes
(Void or light printing)

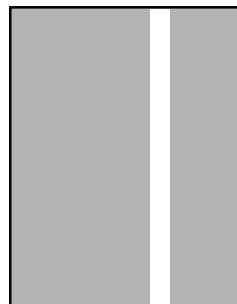

5.4 Cleaning of Pick-up Roller

When papers are not fed normally, the Pick-up roller should be cleaned.

Note: Clean it with a soft cloth and alcohol. Be cautious not to damage the roller surface.

6. TROUBLESHOOTING PROCEDURES

6.1 Tips for Troubleshooting

- (1) Check the basic check points covered in the user's manual.
- (2) Gather as much information on the problem from the customer as possible.
- (3) Perform inspections in conditions close to those in which the problem had occurred.

6.2 Check Points before Correcting Image Problems

- (1) Is the printer being run in proper ambient conditions?
- (2) Have the consumables toner and image drum cartridges been replaced properly?
- (3) Is the paper normal? See paper specifications section.
- (4) Has the image drum cartridge been loaded properly?

6.3 Tips for Correcting Image Problems

- (1) Do not touch, or bring foreign matter into contact with the image drum surface.
- (2) Do not expose the image drum to direct sunlight.
- (3) Keep hands off the fuser unit as it is heated during operation.
- (4) Do not expose the image drum to light for longer than 3 minutes at room temperature.

6.4 Preparation for Troubleshooting

(1) Operator panel display

The failure status of this printer is indicated on the LCD (liquid crystal display) of the Operator panel.

Take the proper corrective action according to the message displayed on the LCD.

6.5 Troubleshooting Flow

If a problem should develop in this printer, troubleshoot in the following procedure.

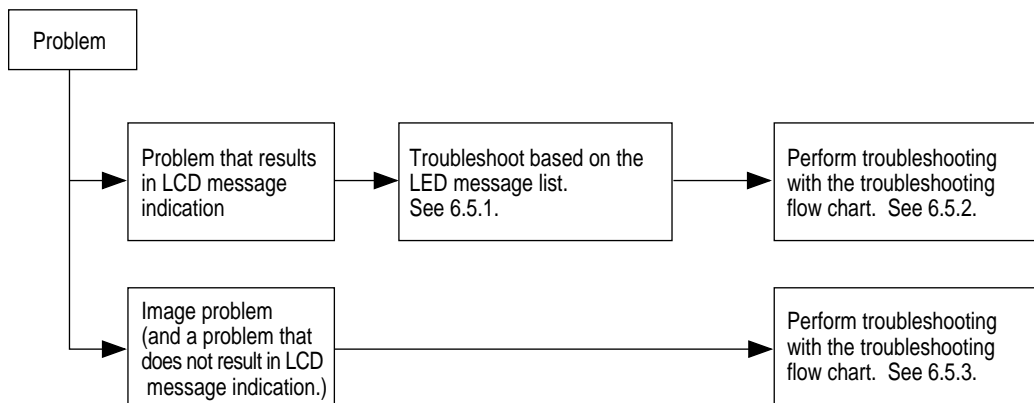

6.5.1 LCD Message List

The printer indicates a Service Call Error message on the LCD as shown below, detecting an unrecoverable error.

Service Call
nnn : Error

Note: nnn is an error code.

When the Service Call message is displayed, the error information corresponding to the error code appears on the lower line of the LCD. The meaning and solutions of each error code are listed in the Table 6-1-1.

Table 6-1-1 Operator Alarms (1/5)

Message	Cause	Error Description		Solutions
Service Call 001: Error ~ 011: Error	CPU Exception	Is the error message displayed again? Is the error message displayed again?	Yes Yes	Turn the printer off/on. Replace the CRM board. (The EEPROM needs replacement.)
Service Call 020: Error	CU ROM Hash Check Error 1	Is the program ROM DIMM installed properly? Can the printer recover from the error by replacing the program ROM DIMM?	No Yes No	Re-install the program ROM DIMM. Replace the program ROM DIMM. Replace the CRM board. (The EEPROM needs replacement.)
Service Call 030: Error	CU Slot1 DIMM RAM Check Error	Is the concerned RAM DIMM installed properly? Can the printer recover from the error by replacing the RAM DIMM?	No Yes No	Re-install the concerned RAM DIMM. Replace the RAM DIMM. Replace the CRM board. (The EEPROM needs replacement.)
Service Call 031: Error	CU Slot2 DIMM RAM Check Error	Is the concerned RAM DIMM installed properly? Can the printer recover from the error by replacing the RAM DIMM?	No Yes No	Re-install the concerned RAM DIMM. Replace the RAM DIMM. Replace the CRM board. (The EEPROM needs replacement.)
Service Call 032: Error	CU Slot3 DIMM RAM Check Error	Is the concerned RAM DIMM installed properly? Can the printer recover from the error by replacing the RAM DIMM?	No Yes No	Re-install the concerned RAM DIMM. Replace the RAM DIMM. Replace the CRM board. (The EEPROM needs replacement.)
Service Call 033: Error	CU Slot4 DIMM RAM Check Error	Is the concerned RAM DIMM installed properly? Can the printer recover from the error by replacing the RAM DIMM?	No Yes No	Re-install the concerned RAM DIMM. Replace the RAM DIMM. Replace the CRM board. (The EEPROM needs replacement.)
Service Call 034: Error	RAM Configuration Error. The CU RAM installation or derwas not followed.	Is the installation order followed? Can the printer recover from the error by replacing the RAM DIMMs?	No Yes No	Correct the installation order. Replace the RAM DIMMs. Replace the CRM board. (The EEPROM needs replacement.)
Service Call 035: Error	Slot1 RAM Spec Error. The CU RAM Slot1 DIMM specification is not supported.	Is the RAM DIMM a genuine part? Is the concerned RAM DIMM installed properly? Can the printer recover from the error by replacing the RAM DIMM?	No No Yes No	Use a genuine RAM DIMM. Re-install the concerned RAM DIMM. Replace the RAM DIMM. Replace the CRM board. (The EEPROM needs replacement.)
Service Call 036: Error	Slot2 RAM Spec Error. The CU RAM Slot2 DIMM specification is not supported.	Is the RAM DIMM a genuine part? Is the concerned RAM DIMM installed properly? Can the printer recover from the error by replacing the RAM DIMM?	No No Yes No	Use a genuine RAM DIMM. Re-install the concerned RAM DIMM. Replace the RAM DIMM. Replace the CRM board. (The EEPROM needs replacement.)
Service Call 037: Error	Slot3 RAM Spec Error. The CU RAM Slot3 DIMM specification is not supported.	Is the RAM DIMM a genuine part? Is the concerned RAM DIMM installed properly? Can the printer recover from the error by replacing the RAM DIMM?	No No Yes No	Use a genuine RAM DIMM. Re-install the concerned RAM DIMM. Replace the RAM DIMM. Replace the CRM board. (The EEPROM needs replacement.)
Service Call 038: Error	Slot4 RAM Spec Error. The CU RAM Slot4 DIMM specification is not supported.	Is the RAM DIMM a genuine part? Is the concerned RAM DIMM installed properly? Can the printer recover from the error by replacing the RAM DIMM?	No No Yes No	Use a genuine RAM DIMM. Re-install the concerned RAM DIMM. Replace the RAM DIMM. Replace the CRM board. (The EEPROM needs replacement.)

Table 6-1-1 Operator Alarms (2/5)

Message	Cause	Error Description		Solutions
Service Call 040: Error	CU EEPROM Error	Can the printer recover from the error by replacing the EEPROM on the CU board?	Yes No	Replace the EEPROM. (Settings of the user must be restored on the new.) Replace the CRM board. (The EEPROM needs replacement.)
Service Call 041: Error	U Flash Error. On-CU-board Flash ROM Error	Does the error message appear again?	Yes	Replace the CRM board. (The EEPROM needs replacement.)
Service Call 050: Error	Operator Panel Error	Does the error message appear again?	Yes	See the flowchart for the problems with no LCD message displayed.
Service Call 051: Error	CU Fan Error. On-CU-board CPU Cooling Fan Problem	Is the on-CU-board connector connected properly? Can the printer recover from the error by replacing the fan?	No Yes No	Connect the connector properly. Replace the fan. Replace the CRM board. (The EEPROM needs replacement.)
Service Call 063: Error	Network Comm.Error. CU ~ NIC H/W I/F Problem	Is the network board installed properly? Can the printer recover from the error by replacing the network board?	No Yes No	Install the network board properly. Replace the network board. Replace the CRM board. (The EEPROM needs replacement.)
Service Call 070: Error	CANT_HAPPEN. PS F/W Problem Detection	Is it recovered by turning the printer off/on.	No	Replace the CRM board. (The EEPROM needs replacement.)
Service Call 072: Error	Engine Communication Error PU ~ CU I/F Error	Is the CU Assy installed properly? Can the printer recover from the error by replacing the CRM board?	No Yes No	Install the CU Assy properly. Replace the CRM board. (The EEPROM needs replacement.) Replace the PU board.
Service Call 073: Error ~ 075: Error	Video Overrun Detect	Is the CU Assy installed properly? Can the printer recover from the error by replacing the CRM board?	No Yes	Install the CU Assy properly. Replace the CRM board. (The EEPROM needs replacement.)
Service Call 100/100:Error	Error detected at Engine ROM Checksum when turned on.	Does the error repeat?	No Yes	Replace the PU board. Replace the engine control board (K73).
Service Call 102: Error	Error detected at Engine RAM Read/Write when turned on.	Does the error repeat?	Yes	Replace the engine control board (K73).
Service Call 103: Error	Error detected at Engine SRAM Read/Write when turned on.	Does the error repeat?	Yes	Replace the engine control board (K73).
Service Call 104: Error	Error detected at Engine EEPROM Checksum when turned on.	Does the error repeat?	Yes	Replace the engine control board (K73).
Service Call 105: Error	EEPROM not detected when turned on.	No EEPROM? Does the error repeat?	Yes Yes	Confirm the existence of EEPROM. Without it, mount an EEPROM. Replace the engine control board (K73).
Service Call 106: Error	Error detected at Engine Control Logic.	Does the error repeat?	Yes	Replace the engine control board (K73).
Service Call 120: Error ~ 122: Error	Error detected at the Power unit cooling fan in the Controller cavity.	1) Is the error message displayed? 2) Does the error repeat?	Yes Yes	Turn off/on the printer. Replace the Fan motor.
Service Call 123: Error	Inappropriate ambient RH detected by a sensor.	1) Is the error message displayed? 2) Does the error repeat?	Yes Yes	Turn off/on the printer. Replace the RH sensor.
Service Call 124: Error	Inappropriate ambient temp. detected by a sensor.	1) Is the error message displayed? 2) Does the error repeat?	Yes Yes	Turn off/on the printer. Replace the temperature sensor.

Table 6-1-1 Operator Alarms (3/5)

Message	Cause	Error Description		Solutions
Service Call 125: Error	Error detected at the MT home position.	1) Is the error message displayed? 2) Does the error repeat?	Yes Yes	Turn off/on the printer. Replace the MT.
Service Call 130: Error	Temperature rise at the LED head detected.	1) Is the error message displayed? 2) Does the error repeat?	Yes Yes	Turn off the printer, leave it for 30 min and then turn it on again. Replace the LED head unit.
Service Call 131: Error ~ 134: Error	No LED head unit detected when turning on the printer or closing the cover.	1) Is the error message displayed? 2) Is the LED head mounted properly? 3) Does the error repeat?	Yes Yes Yes	Verify the installation of the LED head. Turn off/on the printer. Replace the LED head Assy.
Service Call 140: Error ~ 142: Error	Error detected with the D located at appropriate position.	1) Is the error message displayed? 2) Does the error repeat?	Yes Yes	Turn off/on the printer. Replace the Drum Assy.
Service Call 150: Error ~ 153: Error	Fuse in the ID unit has not been blown.	Is the ID unit mounted properly?	Yes	Confirm the cable connection, or replace the Engine board.
Service Call 154: Error	Fuse in the Belt unit has not been blown.	Is the Belt unit mounted properly?	Yes	Confirm the cable connection, or replace the Engine board.
Service Call 155: Error	Fuse in the Fuser unit has not been blown.	Is the Fuser unit mounted properly?	Yes	Confirm the cable connection, or replace the Engine board.
Service Call 160: Error ~ 163: Error	Error detected by Toner sensor.	1) Is the error message displayed? 2) Does the error repeat?	Yes Yes	Replace Toner sensor or Assy (Y71-PWB). Same as the above.
Service Call 170: Error 171: Error 174: Error 175: Error	Short or open circuit detected at the Fuser thermistor. (H or L temperature error)	1) Is the error message displayed? 2) Does the error repeat?	Yes Yes	Turn off/on the printer. Replace the Thermistor and turn off the printer. Leave it for 30 min.
Service Call 172: Error 176: Error	High temperature error detected at Thermistor.	1) Is the error message displayed? 2) Does the error repeat?	Yes Yes	Turn off/on the printer. Replace the Thermistor and turn off the printer. Leave it for 30 min.
Service Call 173: Error 177: Error	Low temperature error detected at Thermistor.	1) Is the error message displayed? 2) Does the error repeat?	Yes Yes	Turn off/on the printer. Replace the Thermistor or heater and turn off the printer.
Service Call 181: Error ~ 186: Error	Communication failure with an option unit detected by Engine	1) Is the error message displayed? 2) Does the error repeat?	Yes Yes	Turn off/on the printer. Replace the option unit.
Close Cover 310: CCCC CoverOpen (* = A4, B4 etc.)	Printer engine cover is open.	1) Is the Top cover open? 2) Does the Cover switch operatenormally?	Yes Yes No	Close the Top cover. Close the Side cover. Replace the Cover switch.
Check Fuser 320: Fuser Error	No Fuser unit detected when turning on the printer or closing the cover.	1) Is the error message displayed? 2) Is the Fuser unit mounted properly? 3) Does the error repeat?	Yes No Yes	Confirm the existence of the unit. Re-install the Fuser unit and turn off/on the printer. Replace the Fuser unit Assy.
Check Belt 330: Belt Error	No Belt unit detected when turning on the printer or closing the cover.	1) Is the error message displayed? 2) Is the Belt unit mounted properly? 3) Does the error repeat?	Yes No Yes	Confirm the existence of the unit. Re-install the Belt unit and turn off/on the printer. Replace the Belt unit Assy.
Check Drum 340~343: Drum Error	No ID unit detected when turning on the printer or closing the cover.	1) Is the error message displayed? 2) Is the ID unit mounted properly? 3) Does the error repeat?	Yes No Yes	Confirm the existence of the unit. Re-install the ID unit and turn off/on the printer. Replace the ID unit Assy.

Table 6-1-1 Operator Alarms (4/5)

Message	Cause	Error Description		Solutions
Install New Drum 350: Y Drum Life 351: M Drum Life 352: C Drum Life 353: K Drum Life	End of the ID unit life. 26,000 or more copies printed.	Is it displayed soon after the ID unit replacement?	Yes No	Confirm the life of the ID unit. Replace the ID unit.
Install Duplex Unit 360: No Duplex unit	The Duplex unit is removed from the printer.	Recovered if the Duplex unit is inserted again?	Yes No	Normal Replace the Duplex unit or Engine board.
Check DUPLEX 370: Paper Jam	Paper jam detected after paper reverse in the Duplex unit.	1) Is a paper jammed in the Duplex unit?	Yes No	Remove the jammed paper. Check the Duplex unit, or replace it.
Check DUPLEX 371: Paper Jam	Paper jam detected at the Duplex unit	1) Is a paper jammed in the Duplex unit?	Yes No	Remove the jammed paper. Check the Duplex unit, or replace it.
Check DUPLEX 372: Paper Jam	Paper jam detected during paper feed from the Duplex unit.	1) Does misfeed occur in the Duplex unit?	Yes No	Remove the misfed paper and close the cover. Check the Duplex unit, or replace it.
Open Side Cover 380: Paper Jam	Paper jam during paper feed from the Cassette 1, 2, 3, 4 or 5.	1) Does misfeed occur in the specified cassette?	Yes No	Remove the jammed paper and install the cassette. Check the Cassette 1, 2, 3, 4 or 5, or replace it.
Open Stacker Cover 381: Paper Jam	Paper jam detected btwn the B ID and Fuser.	1) Is a paper jammed between the Y ID and Fuser? 2) Is the load on the Fuser unit normal?	Yes No	Remove the jammed paper. Replace the Fuser unit.
Open Stacker Cover 382: Paper Jam	Paper jam detected in the Fuser unit or btwn the Fuser and paper ejection.	1) Is a paper jammed in the Fuser unit or between the Y ID and Fuser unit? 2) Is the Paper eject switch work normally?	Yes No	Remove the jammed paper. Replace the Fuser unit.
Open Stacker Cover 383: Paper Jam	Paper jam detected on paper entering the Duplex unit.	1) Is a paper jammed at the entrance of the Duplex unit or in the unit?	Yes No	Remove the jammed paper and close. Check the Duplex unit, or replace it.
Check MP Tray 390: Paper Jam	Paper jam during paper feed from the MP Tray.	1) Does misfeed occur around the MP Tray?	Yes No	Remove the misfed paper and close the cover. Check the MP Tray, or replace it.
Check Tray * 391~395: Paper Jam	Paper jam detected btwn a cassette and the B ID.	1) Is a paper jammed around the cassette or between the B ID and cassette. 2) Does the Paper entry switch operate normal?	Yes No	Remove the jammed paper. Replace the Paper entry switch.
Open Stacker Cover 400: Paper Size Error	Paper in a size different (45 mm or more) from the specification detected at the Printer engine.	1) Is the paper in a custom size? 2) Is the paper in the standard size?	Yes Yes No	No action required. Adjust the Paper size guide of the cassette. Replace the Paper size board (B73 PWB).
Toner Low 410: Yellow 411: Magenta 412: Cyan 413: Black	Toner in one of the four colors is running short.	1) Is the specified toner cartridge almost empty? 2) Does the Toner sensor of the specified cartridge operate normally?	Yes No	Replace it with a new toner kit. Replace the Toner sensor for the specified color.
Remove Printed Papers 480: Stacker Full	The stacker for ejected papers is full.	1) Is the stacker full? 2) Does the Stacker full sensor operate normally?	Yes No	Remove papers from the stacker. Replace the Stacker full sensor.

Table 6-1-1 Operator Alarms (5/5)

Message	Cause	Error Description		Solutions
Load *** Papers 490: No paper in the MP Tray (** = A4, B5 etc.)	The specified cassette has no paper or is removed. Or, the cassette be ingused for printing has no more paper.	1) No paper in MT?	Yes	Load papers in MT.
		2) Does the Paper out sensor operate normally?	No	Replace the Paper out sensor.
Load *** Papers 491~495: No paper in the Tray * (** = A4, B5 etc.)	No paper in the Cassette 1, 2, 3, 4 or 5 detected.	1) No paper in the specified cassette?	Yes	Load papers in the specified cassette.
		2) Does the Paper out sensor operate normally?	No	Replace the Paper out sensor of the specified cassette.
Replace Belt	The belt counter has reached the life value.	1) Is the error message displayed?	Yes	Check the belt life.
		2) Does the error occur soon after Belt unit replacement?	No	Replace the Belt unit immediately or at the next maintenance.
Replace Fuser	The fuser counter has reached the lifevalue	1) Is the error message displayed?	Yes	Check the fuser life.
		2) Does the error occur soon after Fuser unit replacement?	No	Replace the Fuser unit immediately or at the next maintenance.
Job Offset Home Error	The Job offset assy does not operate or cannot detect the home position.	Does the Job offset assy operate normally?	Yes	Replace the Job offset sensor.
			No	Replace the Job offset motor or Engine board.
Running Short of Paper in Tray *	Running short of paper detected	Does only small mount of papers (approx. 30 sheets or less) remain?	Yes	Load papers.
			No	Check the Paper near end sensor.
Disc Operation Error	HDD cannot be written.	Is the operating procedure correct?	No	Confirm the procedure in the manual.
			Yes	Replace the HDD as it is broken.

6.5.2 LCD message troubleshooting

(1) LCD Message

The message on the LCD (liquid crystal display) tells the problem situation of the printer. Implement the appropriate troubleshooting base on the message.

No.	Problem	Flowchart Number
1	The printer does not work normally after being turned on.	①
2	JAM Error Paper Input Jam (1st Tray) Paper Input Jam (MT) Paper Feed Jam Paper Eject Jam DUPLEX Jam	②-1 ②-2 ②-3 ②-4 ②-5
3	Paper Size Error	③
4	I/D Unit Up/Down Error	④
5	Fuser Unit Error	⑤
6	Fan Motor Error	⑥

Note: When replacing the engine board (L73 PWB), demount the EEPROM chip from the old board and remount it on the new one.

① The printer does not work normally after turned on.

- Turn off the printer, wait a few seconds, then turn it on again.
- Is  displayed on the LCD (for about 1 second)?

• No Is the AC cable connected correctly?

No Connect the AC cable correctly.

• Yes Is +5V supplied to the PANEL connector pins on the PU board (K73 PWB)?
+5V: Pin 5 0V: Pin 2

Yes Is the operator panel cable connected correctly?

No Connect the cable correctly.

Yes Replace the operator panel cable. Recovered?

No Replace the cover assembly of the operator panel.

Yes End

• No Is +5V supplied on the POWER connector of the engine board (K73 PWB)?
Pin 11,12, 13, 14: +5V Pin 3, 4, 5, 6, 23, 24, 25, 26, 27, 28, 29, 30: 0V

No Check the connection of the POWER connector, or replace the low-voltage power supply unit.

• Yes Replace the engine board.

• Yes Are the following voltages supplied to the PU connector of the main board?
Pin 137-147, 187-197: +5V Pin 125-136, 175-186: +3.3V
Pin 148, 198: +12V Pin 101-124, 149-174, 199, 200: 0V

Yes Is the main board assy inserted correctly?

No Insert it correctly.

Yes Replace the main board.

• No Are the following voltages supplied on the POWER connector of the engine board?
Pin 11, 12, 13, 14: +5V Pin 15, 16, 17, 18: +3.3V
Pin 1: +12V Pin 2: -12V Pin 7, 8, 9, 10: +32V
Pin 3, 4, 5, 6, 25, 26, 27, 28: 0V

Yes Replace the engine board.

• No Replace the low-voltage power supply unit.

②-1 Paper Input Jam (1st Tray)

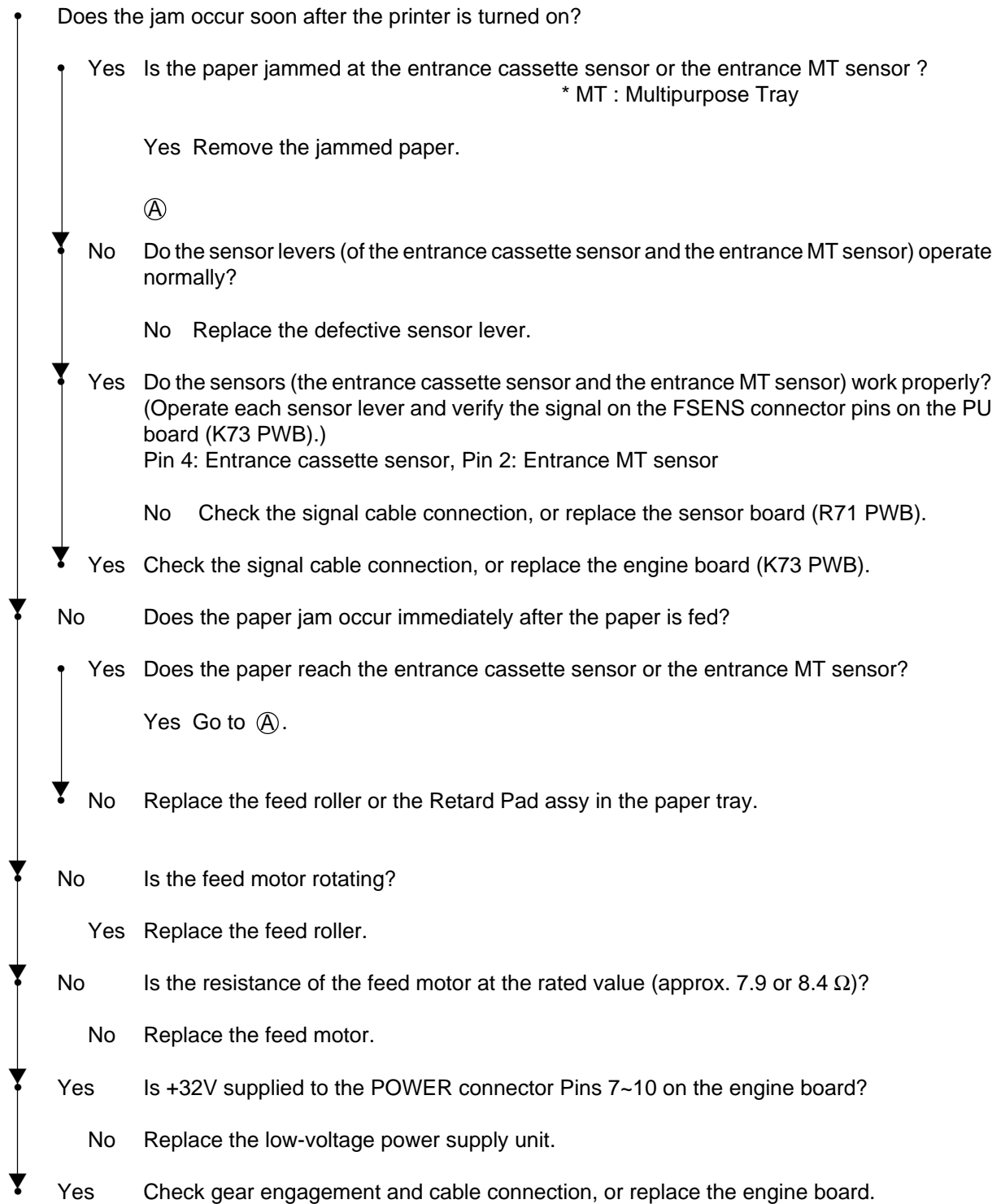

②-2 Paper Input Jam (Multipurpose Tray (MT))

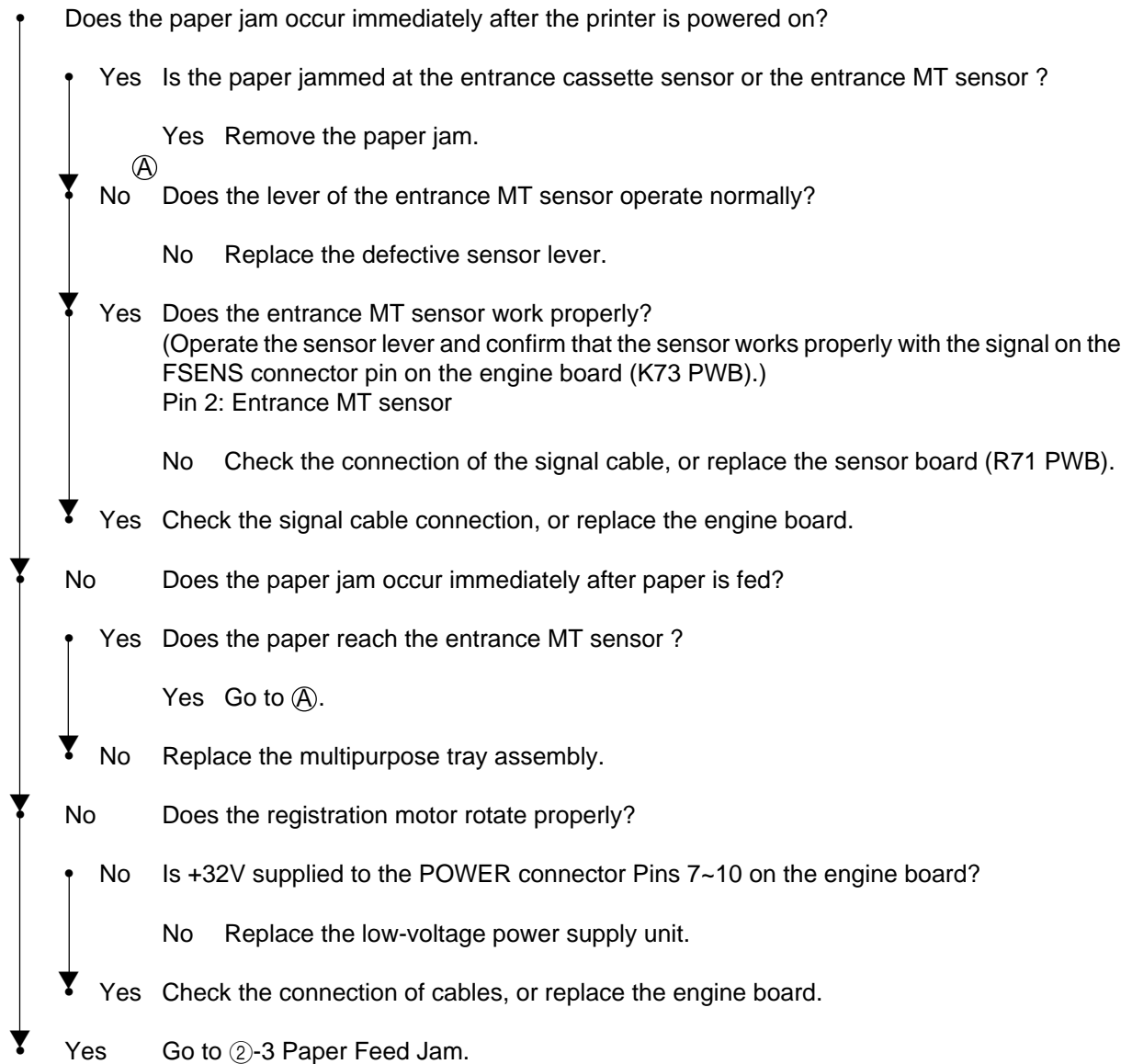

②-3 Paper Feed Jam

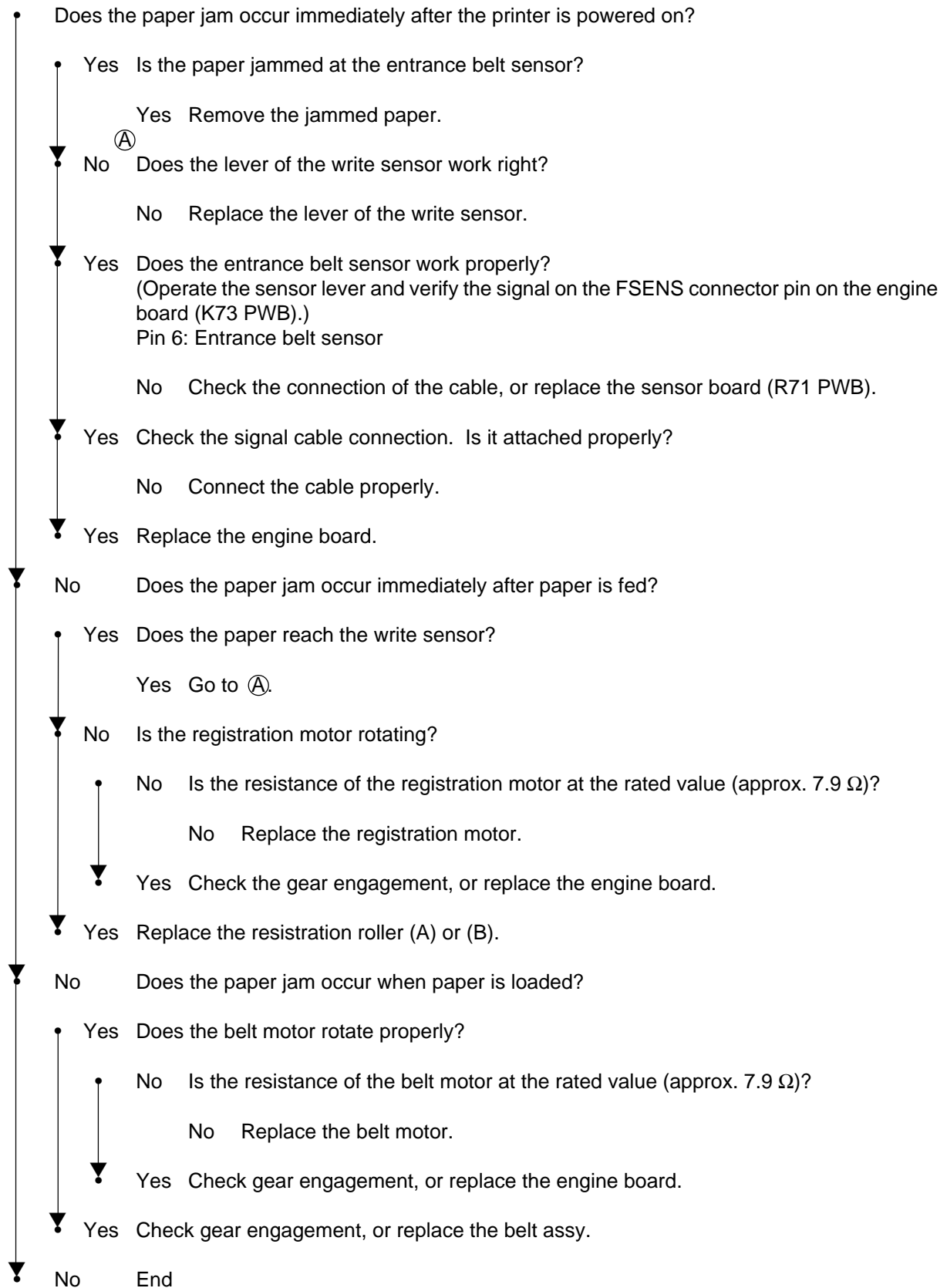

②-4 Paper Eject Jam

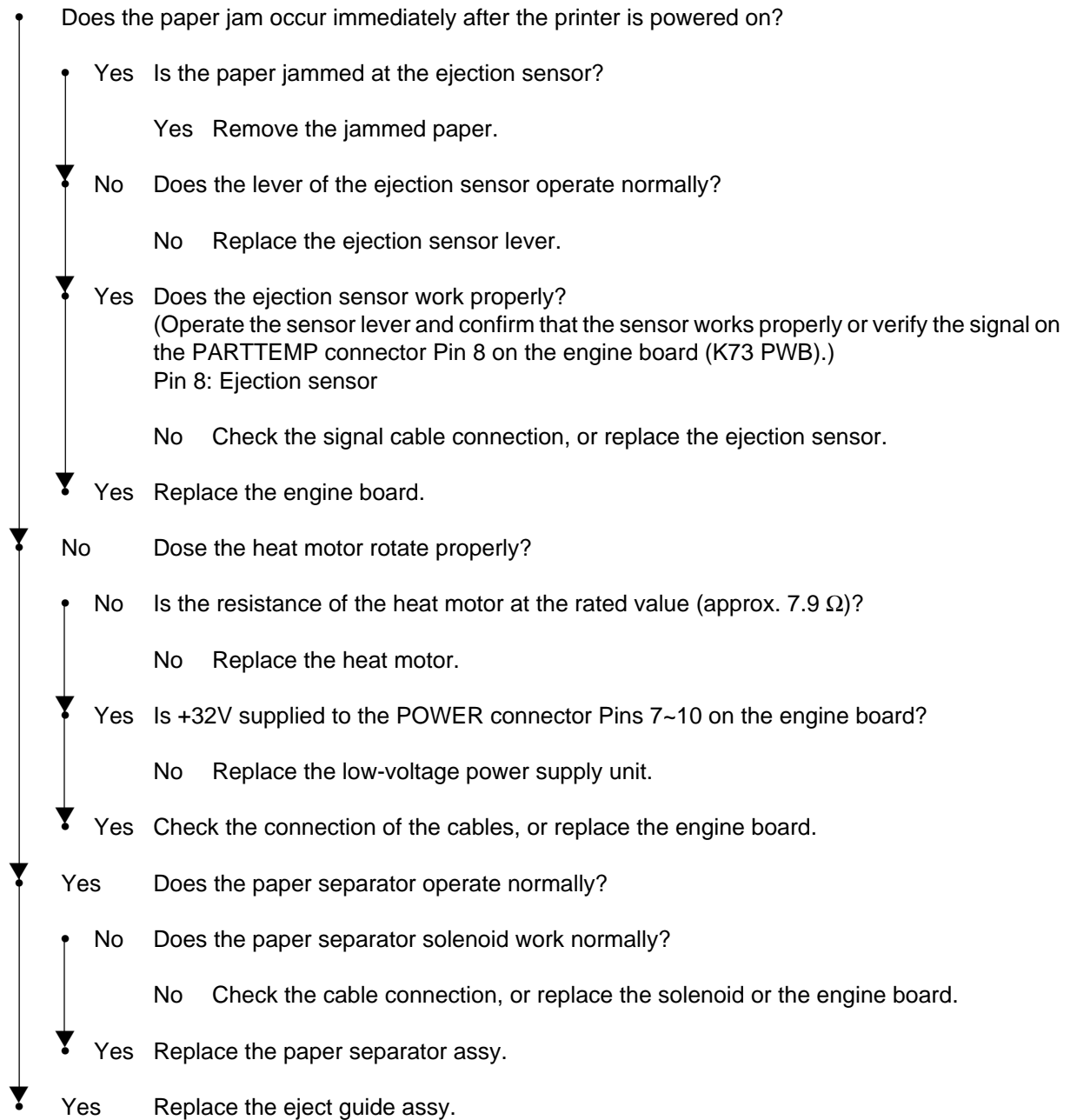

②-5 DUPLEX jam

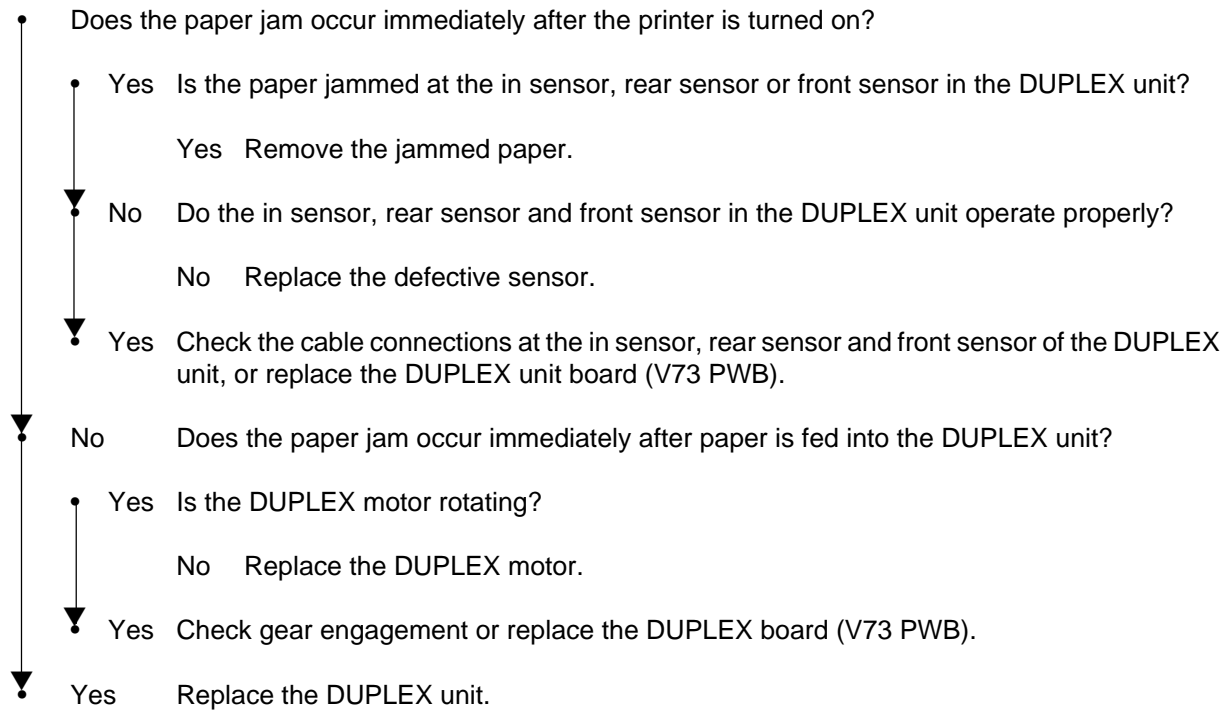

③ Paper Size Error

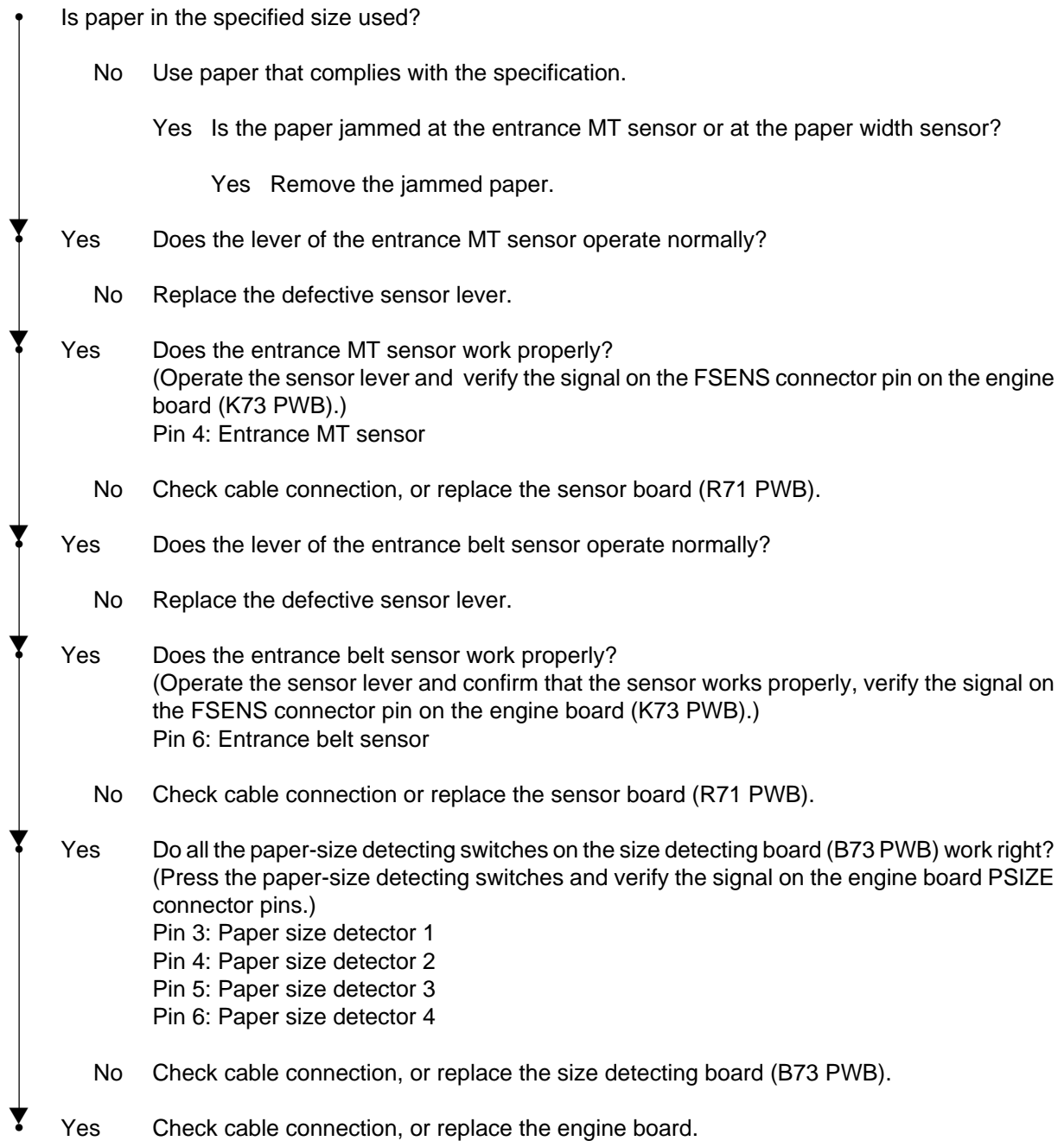

④ Image Drum Unit (IDU) Up/Down Error

- Turn off the printer, wait a few seconds, then turn it on again.
- Does each drum unit rotate properly while printing?
 - No Is the resistance of the IDU motor at the rated value (approx. 4.0 Ω)?
 - No Replace the defective IDU motor.
 - Yes Is +32V supplied to the POWER connector Pins 7~10 on the engine board?
 - No Replace the low-voltage power unit.
 - Yes Check cable connection, or replace the engine board.
- Yes Does the IDU sensor lever work adequately?
 - No Check gear engagement and the sensor lever operation, or replace the defective gear or sensor lever.
- Yes Does the IDU sensor operate properly?
Verify the signal on the JODEN connector pins on the driver board (K73 PWB).
Pin 4: IDU sensor cyan
Pin 14: IDU sensor black
Pin 2: IDU sensor magenta
Pin 12: IDU sensor yellow
 - No Replace the junction board (N73 PWB).
- Yes Check the cable connection between the junction board (N73 PWB) and engine board (K73 PWB), or replace the engine board.

⑤ Fuser Unit Error

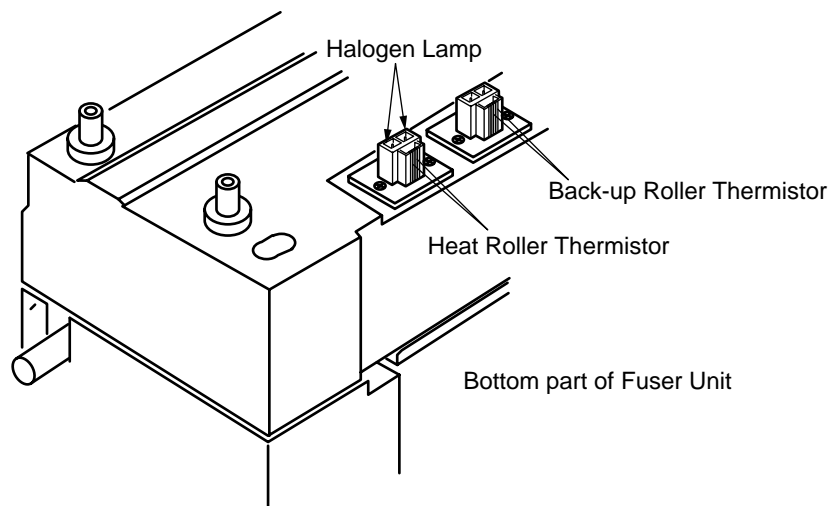
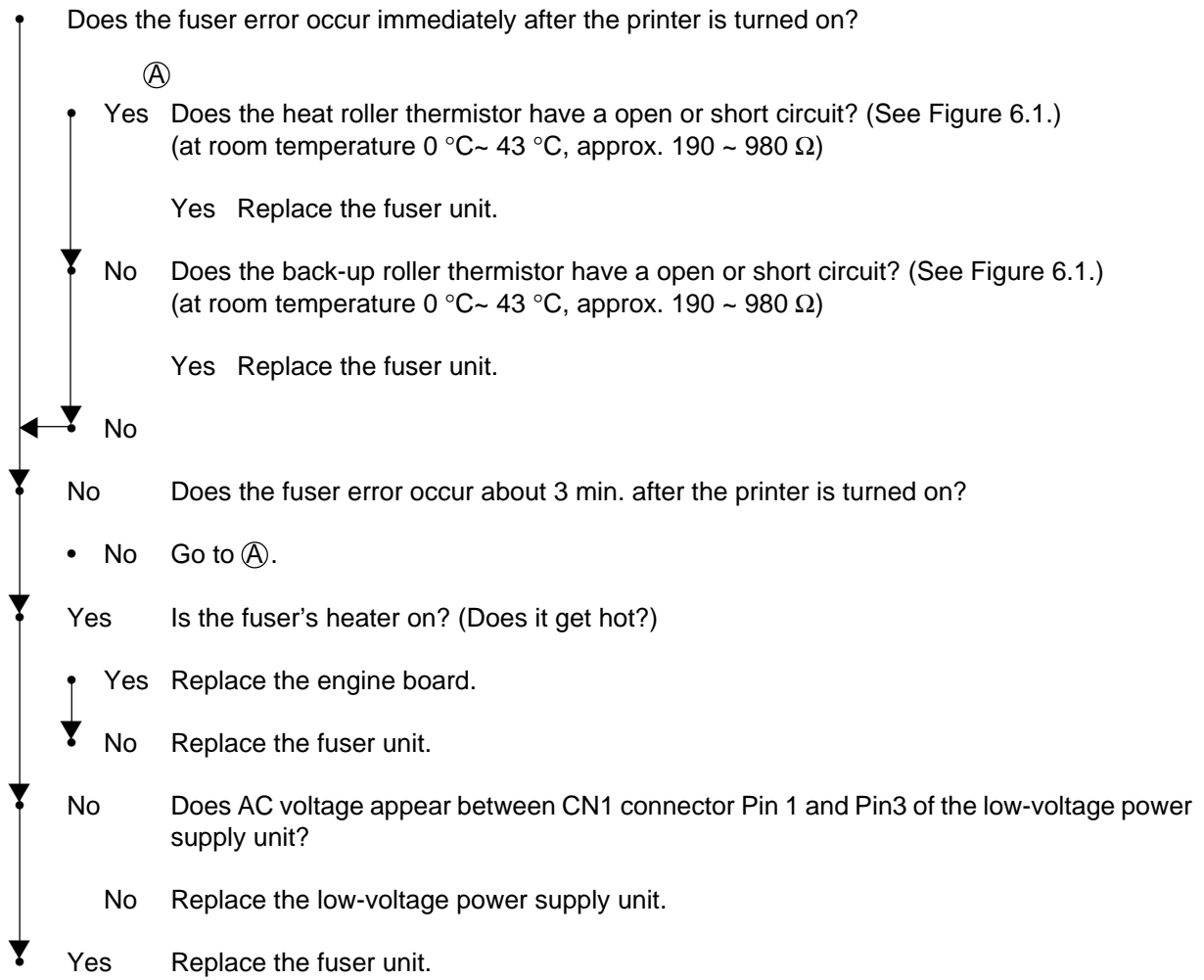
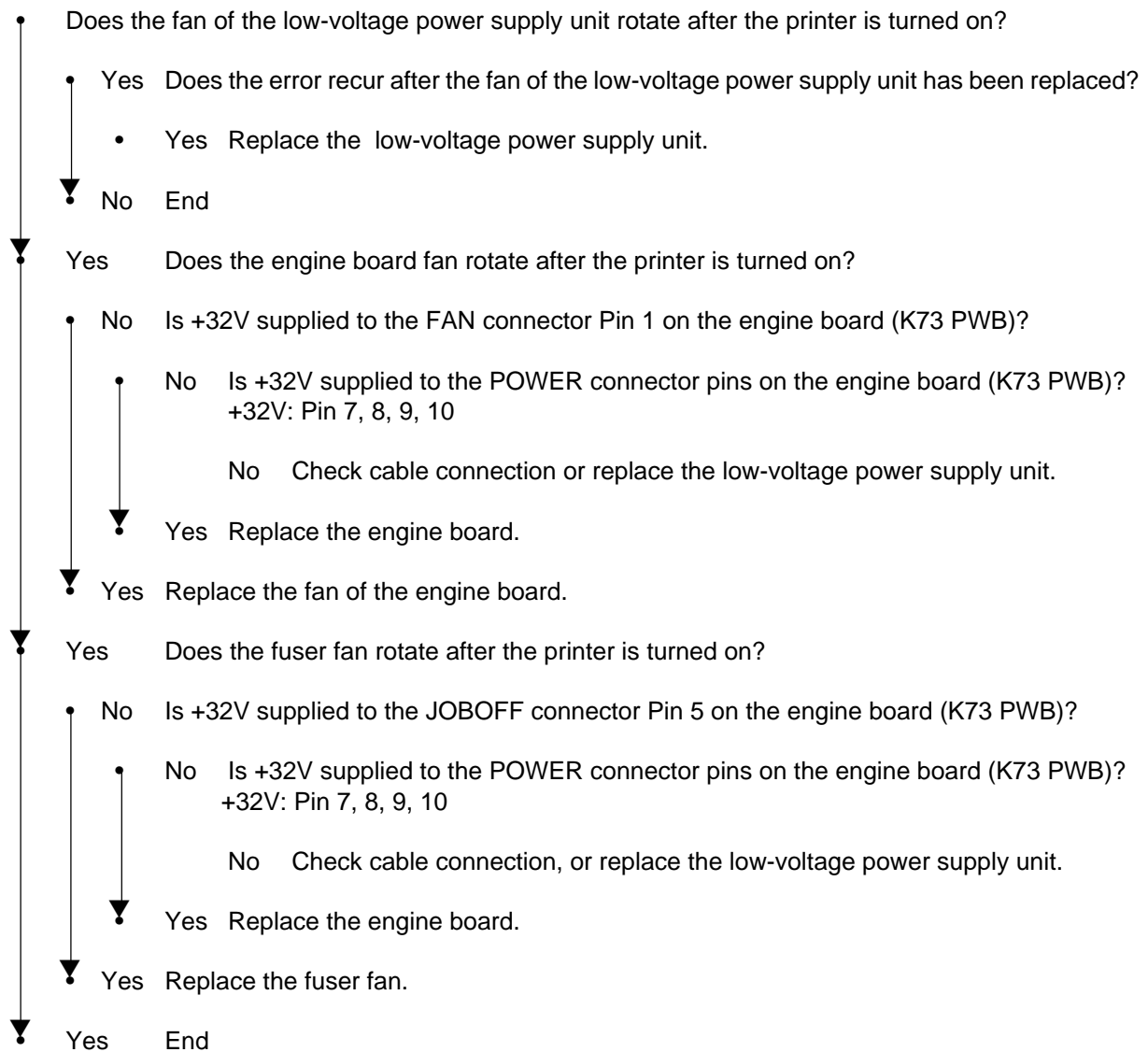

Figure 6.1

⑥ Fan Motor Error



6.5.3 Image troubleshooting

When the printout images are not satisfactory as shown below, follow the troubleshooting procedures given in this section.

Printout problem	Flowchart No.
Light or blurred images, or images in inappropriate color tone (Figure 6.2-(A))	①
Dark background (Figure 6.2-(B))	②
No images on print output (Figure 6.2-(C))	③
Band/stripes in black or color in the longitudinal direction (Figure 6.2-(D))	④
Band/stripes in white or irregular color in the longitudinal direction (Figure 6.2-(E))	⑤
Poor fusing (Images are blurred or peeled off when touched with a hand.)	⑥
Cyclical printout defects (Figure 6.2-(E))	⑦
Missing characters	⑧
Color misalignment	⑨
Printout colors different from the original	⑩

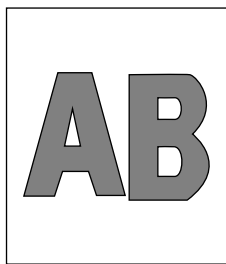

(A) Light or blurred images as a whole

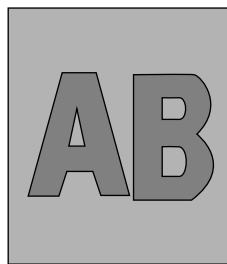

(B) Dark background density

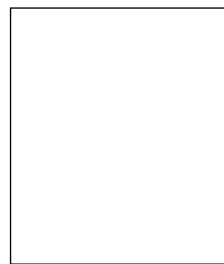

(C) Blank paper

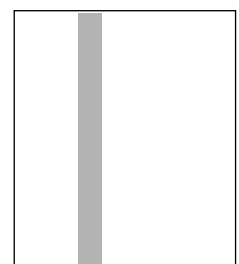

(D) Black stripes in the vertical direction

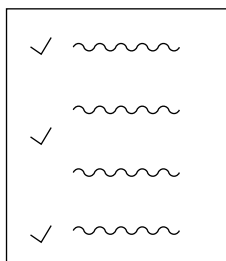

(E) Cyclical defect

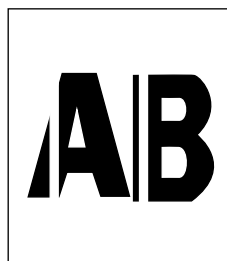

(F) White belts or streaks in the vertical direction

Figure 6.2

① Light or blurred images or images in inappropriate color tone on the whole printout area
(Figure 6.2-Ⓐ)

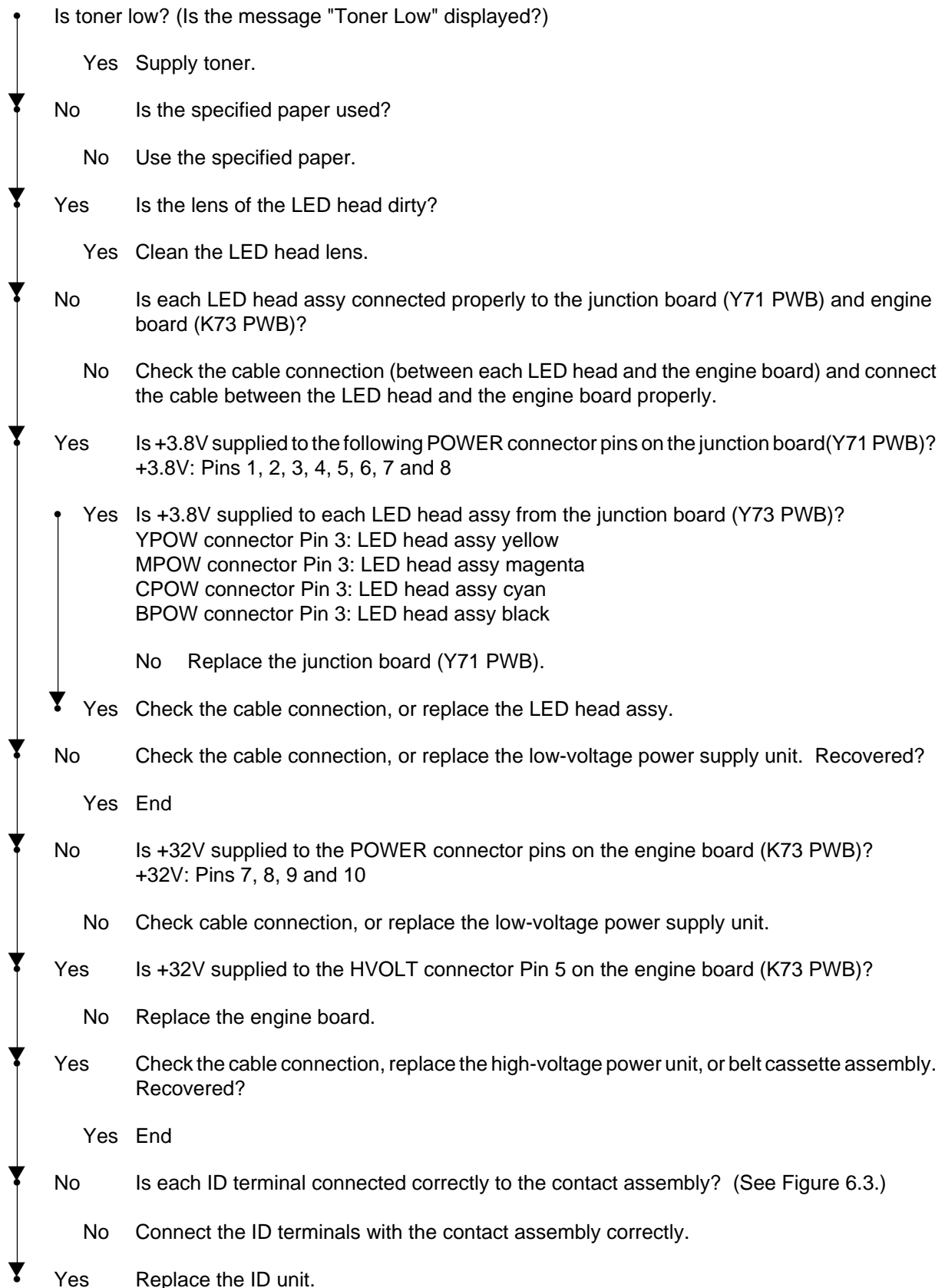

Notes: 1. When replacing the engine board (K73 PWB), demount the EEPROM chip from the old engine board and remount it on the new one.
2. In case the EEPROM chip is not replaced, see Item (2) in Sec. 6.5.2.

② Dark background (Figure 6.2-Ⓑ)

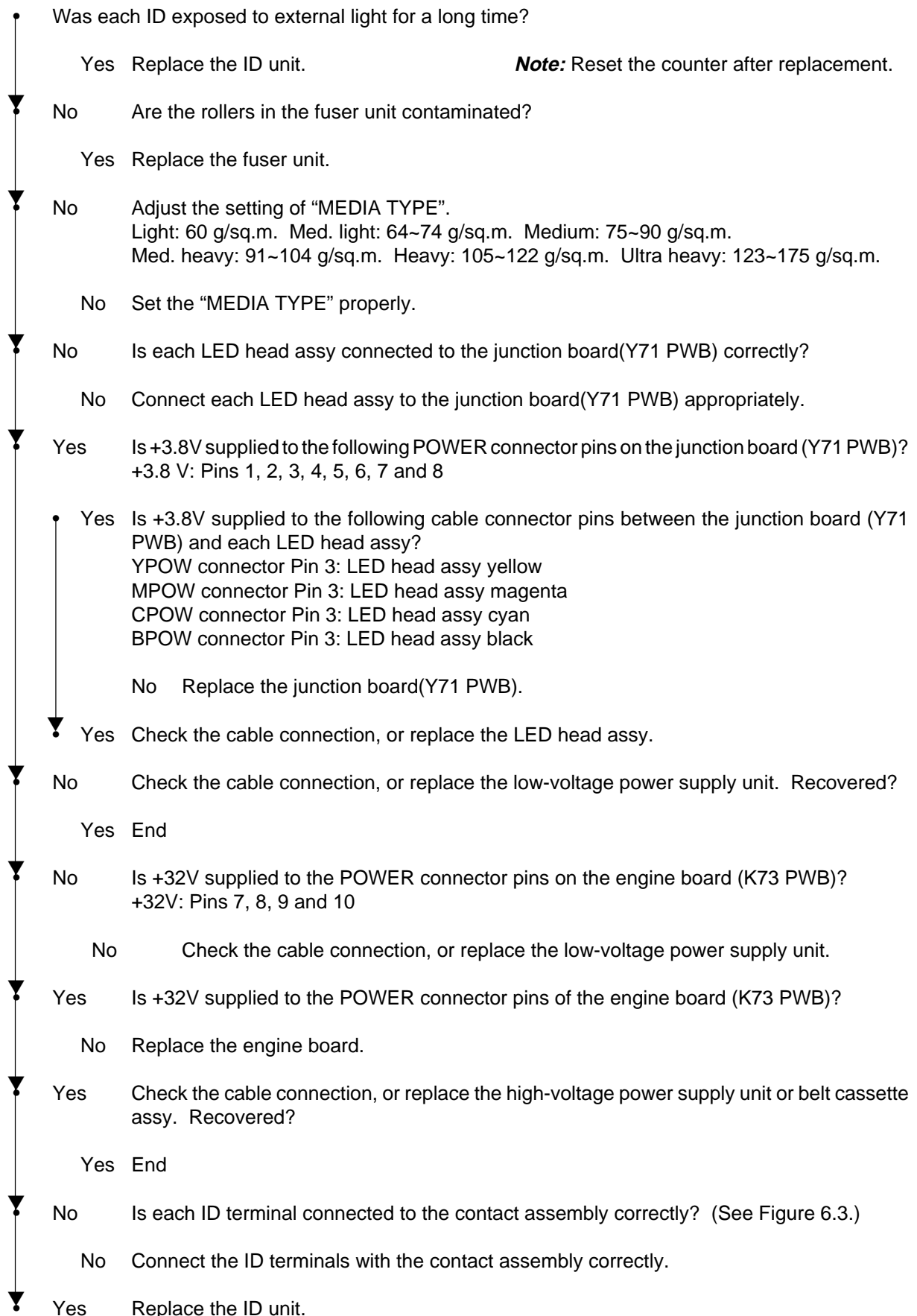

Notes: When replacing the engine board (K73 PWB), demount the EEPROM chip from the old engine board and remount it on the new one.

③ Blank paper (Figure 6.2-©)

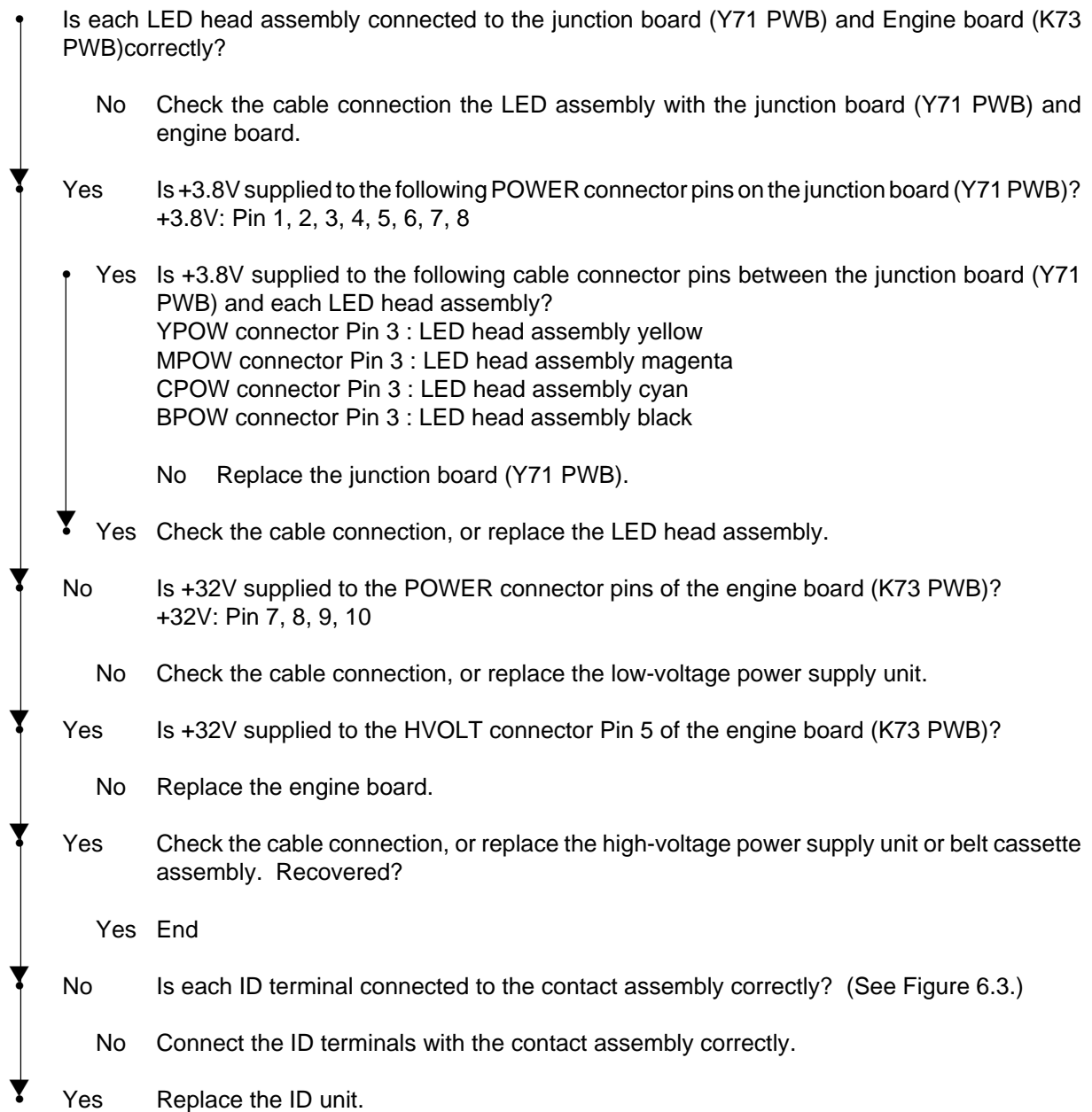

- Notes: 1. When replacing the engine board (K73 PWB), demount the EEPROM chip from the old engine board and remount it on the new one.
2. In case the EEPROM chip is not replaced, see Item (2) in Sec. 6.5.2.

④ Band/stripes in black or color in the longitudinal direction (Figure 6.2-④)

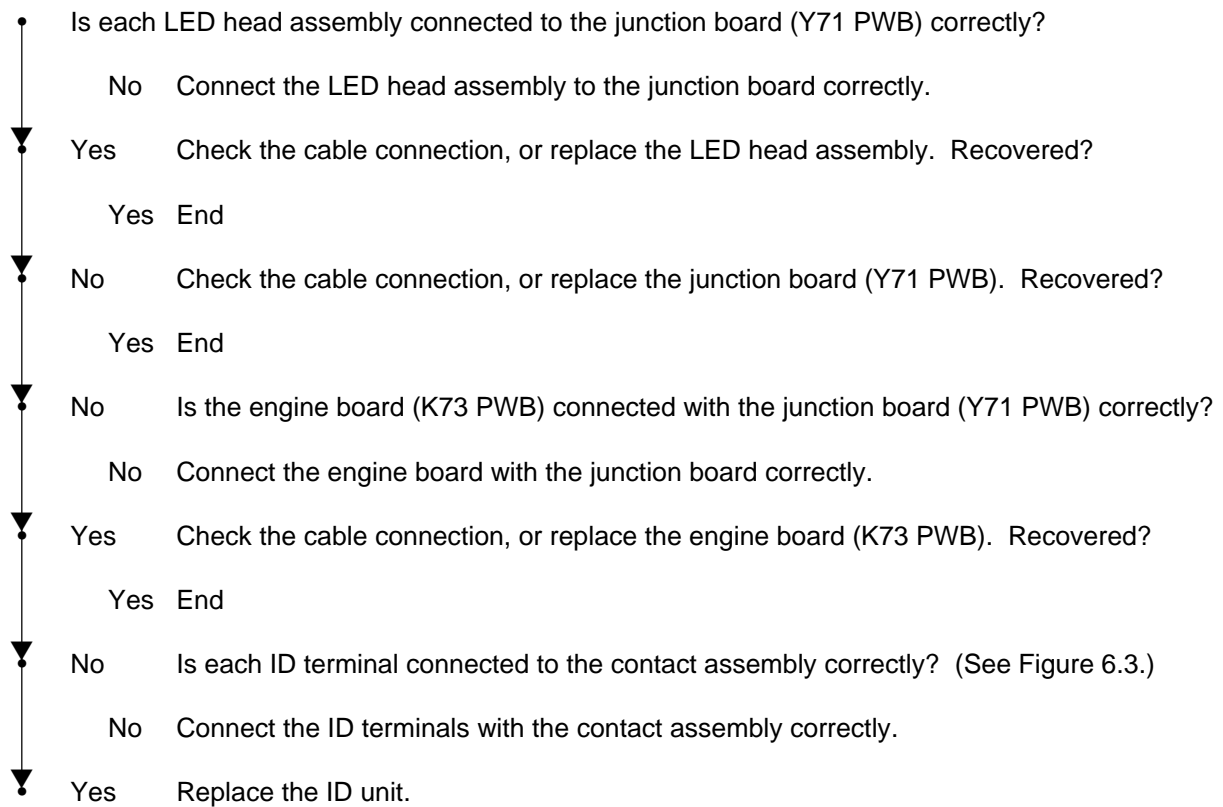

- Notes: 1. When replacing the engine board (K73 PWB), demount the EEPROM chip from the old engine board and remount it on the new one.
2. In case the EEPROM chip is not replaced, see Item (2) in Sec. 6.5.2.

⑤ Band/stripes in white or irregular color in the longitudinal direction (Figure 6.2-Ⓔ)

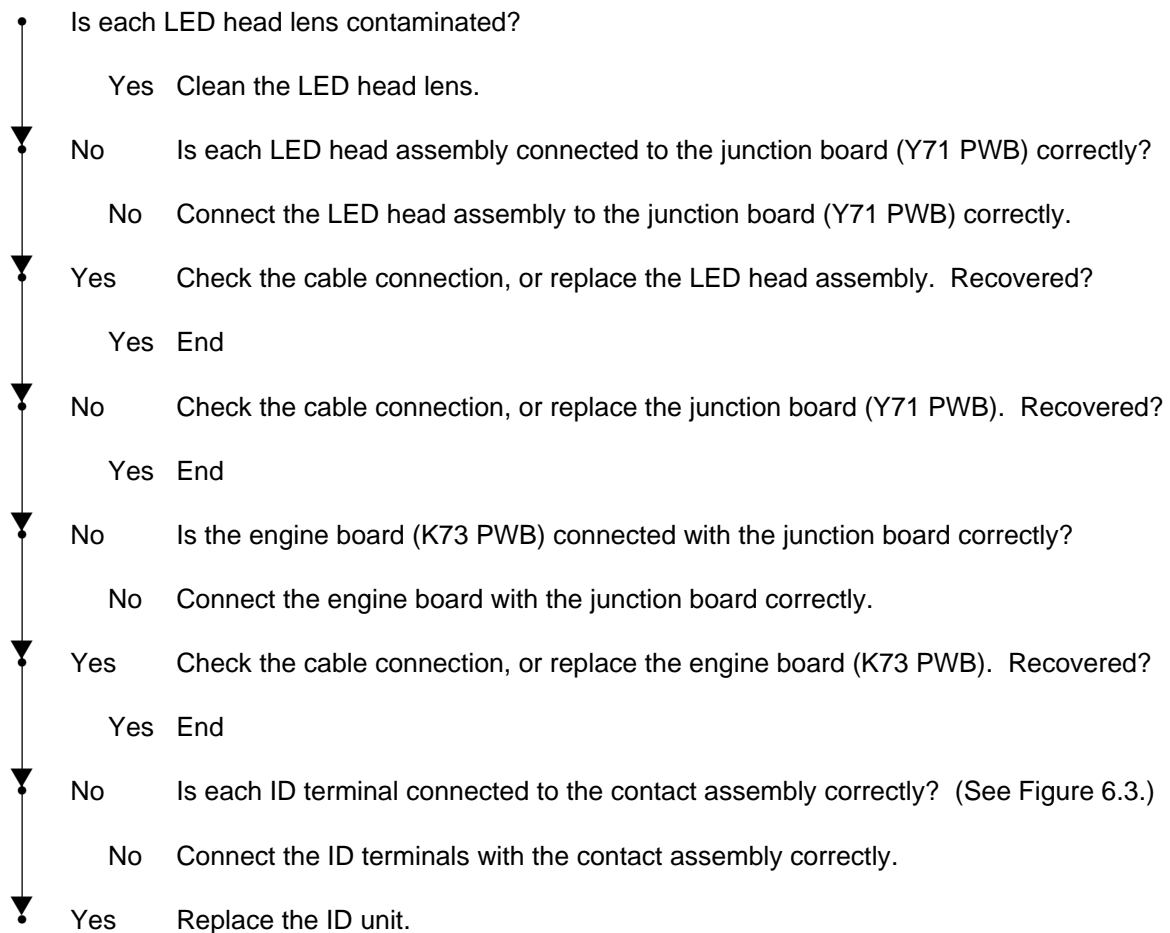

- Notes: 1. When replacing the engine board (K73 PWB), demount the EEPROM chip from the old engine board and remount it on the new one.
2. In case the EEPROM chip is not replaced, see Item (2) in Sec. 6.5.2.

⑥ Poor fusing (Images are blurred or peeled off when touched with a hand.)

- Is the specified paper used?
 - No Use the proper paper.
- ▼
- Yes Is the contact of the fuser unit connected correctly?
 - No Connect the contact of the fuser unit properly.
- ▼
- Yes Are the rollers in the fuser unit contaminated?
 - Yes Replace the fuser unit.
- ▼
- No Is the "MEDIA TYPE" (MENU 1) set correctly?
Light: 60 g/sq.m. Med. light: 64~74 g/sq.m. Medium: 75~90 g/sq.m.
Med. heavy: 91~104 g/sq.m. Heavy: 105~122 g/sq.m. Ultra heavy: 123~175 g/sq.m.
 - No Set the proper "MEDIA TYPE".
- ▼
- Yes Does AC voltage appear between the CN connector Pin 1 and Pin 3 of the low-voltage power supply unit?
 - No Replace the low-voltage power supply unit.
- ▼
- Yes Is the resistance of the heat roller thermistor within the rated value? (See the Figure 6.1.)
(at room temperature 0 °C~ 43 °C, approx. 190 ~ 980 Ω)
 - No Replace the fuser unit.
- ▼
- Yes Is the resistance of the back-up roller thermistor within the rated value? (See the Figure 6.1.)
(at room temperature 0 °C~ 43 °C, approx. 190 ~ 980 Ω)
 - No Replace the fuser unit.
- ▼
- Yes Is the THERM1 signal on the THERM connector Pin 6 on the engine board (K73 PWB) within the range below?
 - No Replace the fuser unit assy.
- ▼
- Yes Replace the fuser unit assy.

Notes: 1. When replacing the engine board (K73 PWB), demount the EEPROM chip from the old engine board and remount it on the new one.
2. In case the EEPROM chip is not replaced, see Item (2) in Sec. 6.5.2.

⑦ Cyclical printout defects (Figure 6.2-⑤)

Cycle	Defective Part	Solution
3.71 in.	Image Drum	Replace the ID unit.
1.95 in.	Developing Roller	Replace the ID unit.
2.66in.	Toner Supply Roller	Replace the ID unit
1.73 in.	Charge Roller	Replace the ID unit.
4.45 in.	Fuser Roller	Replace the fuser unit.
2.28 in.	Transfer Roller	Replace the belt cassette assembly.

Note: After replacement of the ID unit, fuser unit or belt cassette unit, the corresponding counter will be reset.

⑧ Missing characters

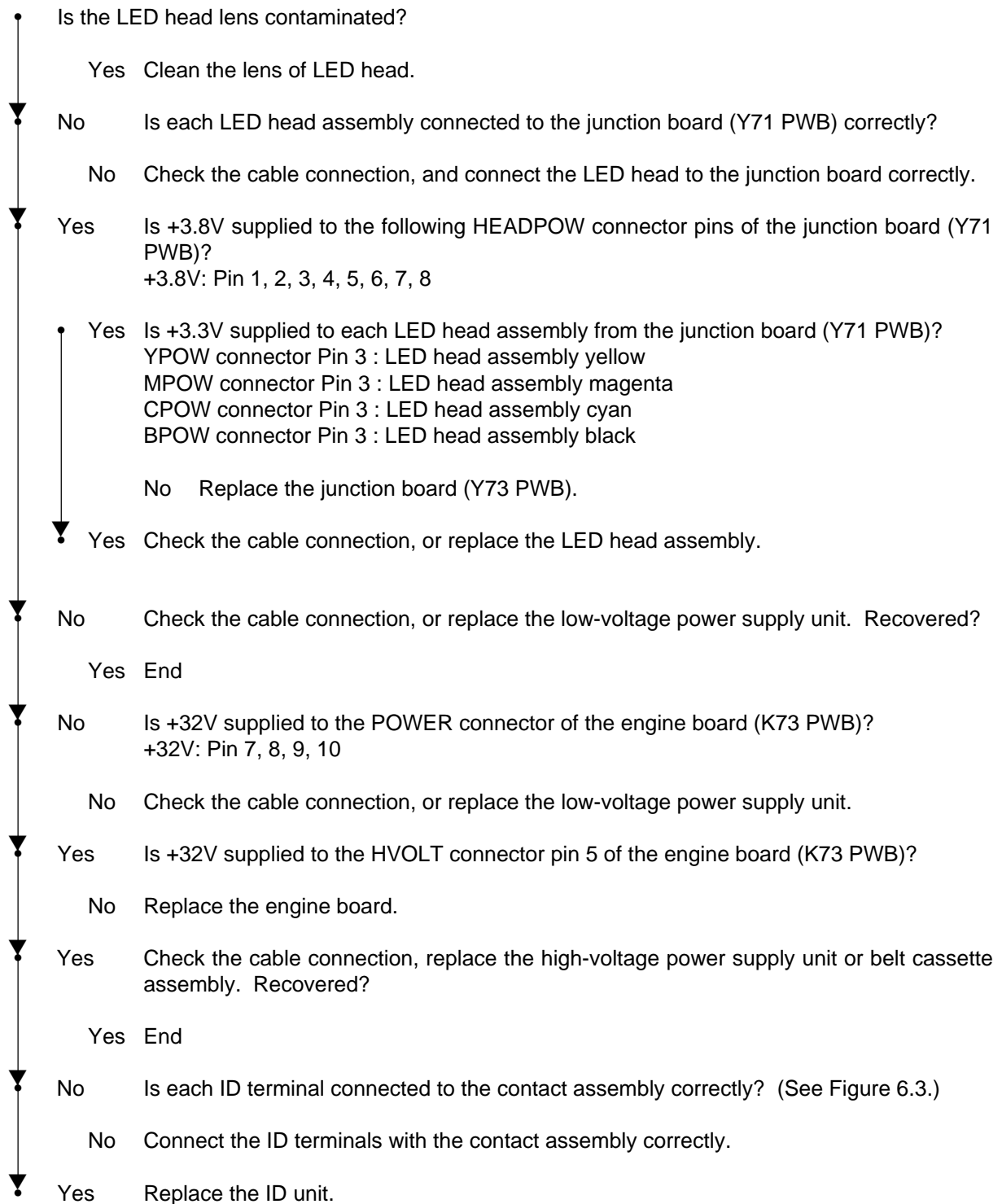

- Notes: 1. When replacing the engine board (K73 PWB), demount the EEPROM chip from the old engine board and remount it on the new one.
2. In case the EEPROM chip is not replaced, see Item (2) in Sec. 6.5.2.

⑨ Color Misalignment

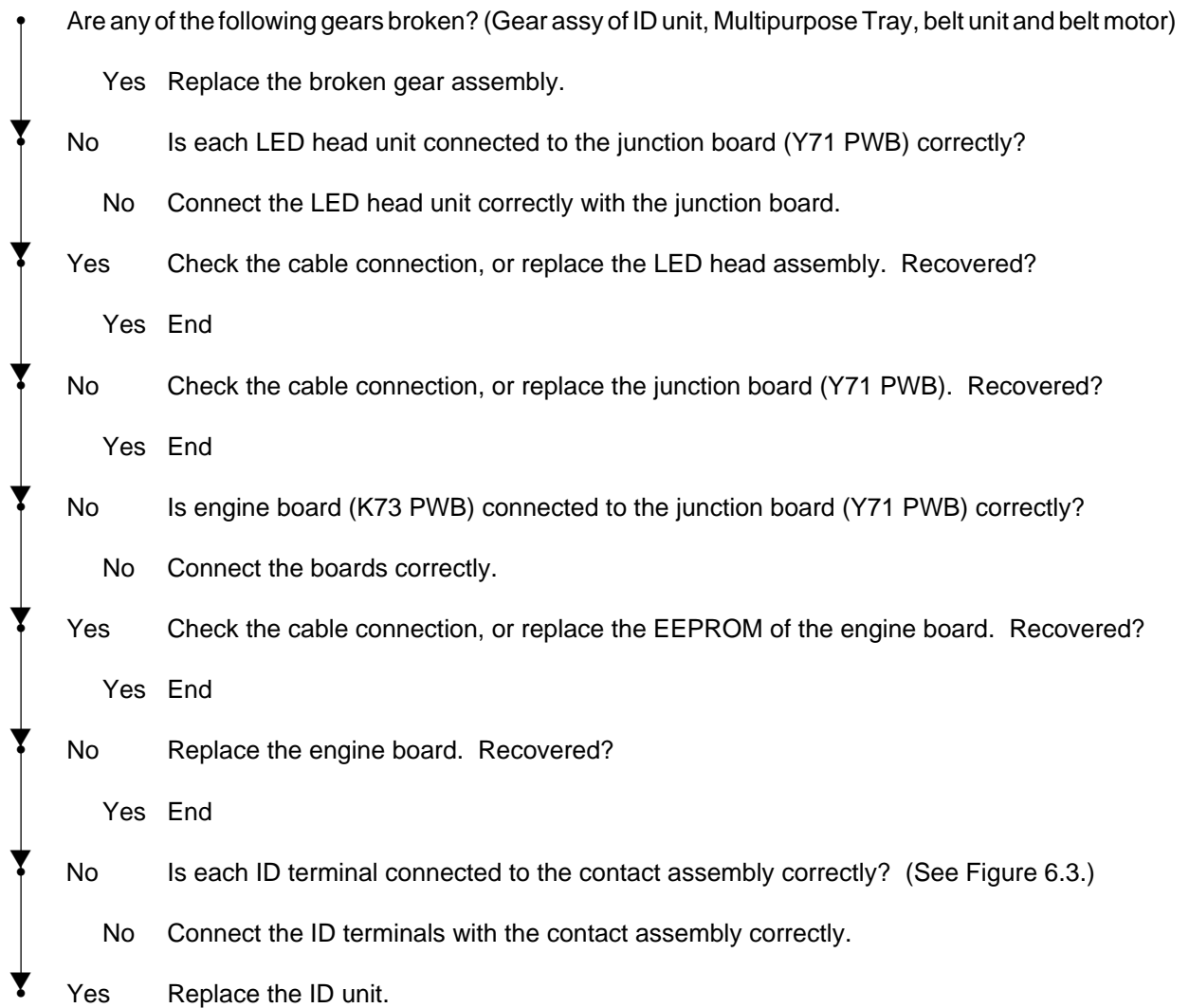

- Notes: 1. When replacing the engine board (K73 PWB), demount the EEPROM chip from the old engine board and remount it on the new one.
2. In case the EEPROM chip is not replaced, see Item (2) in Sec. 6.5.2.

⑩ Printout colors different from the original

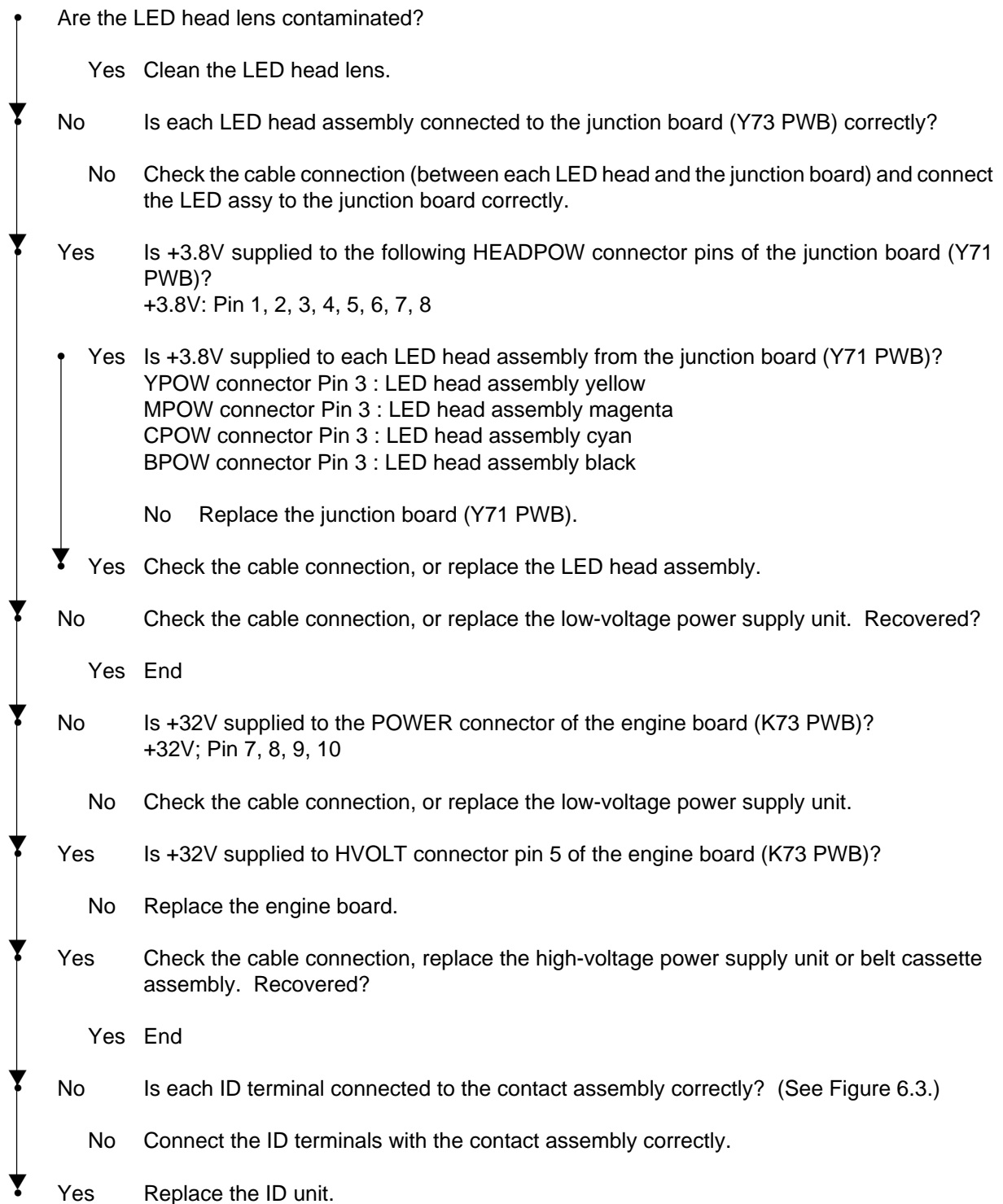

- Notes: 1. When replacing the engine board (K73 PWB), demount the EEPROM chip from the old engine board and remount it on the new one.
2. In case the EEPROM chip is not replaced, see Item (2) in Sec. 6.5.2.

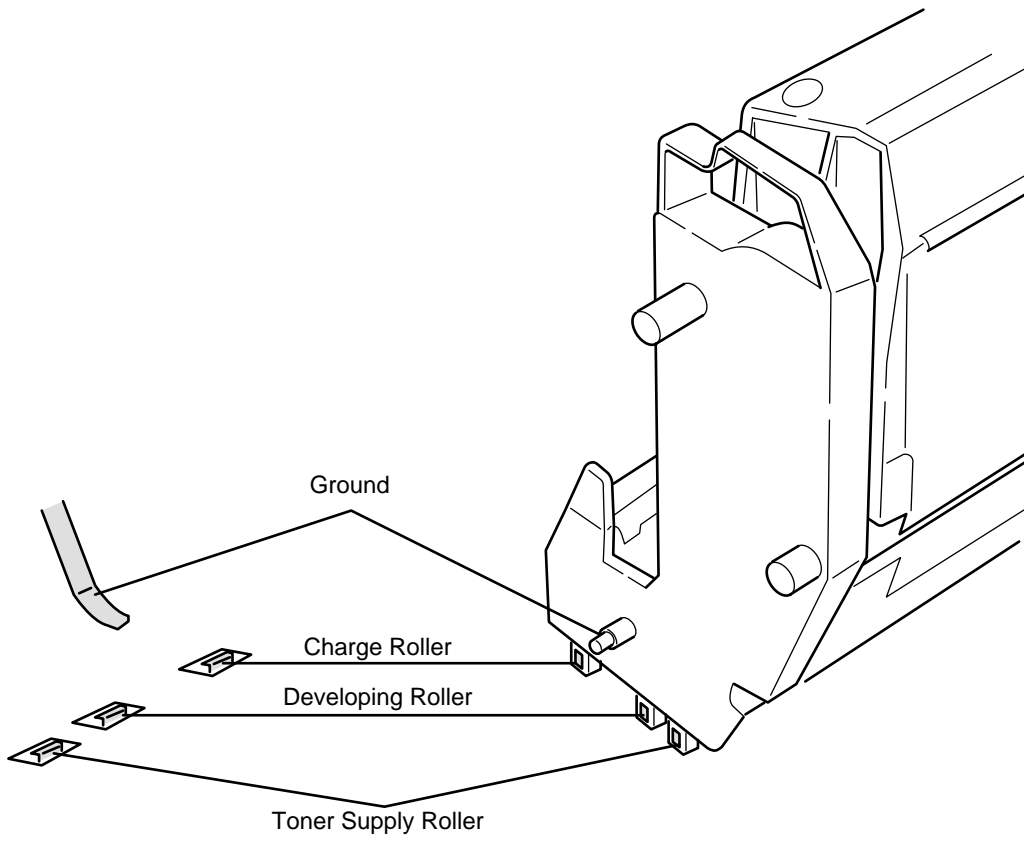
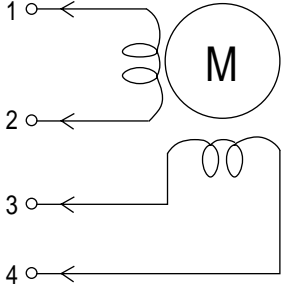
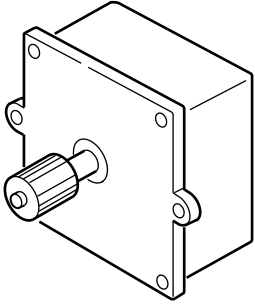
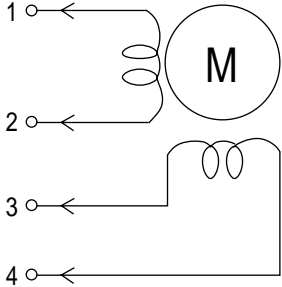
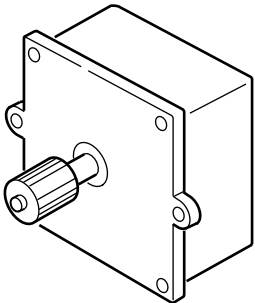
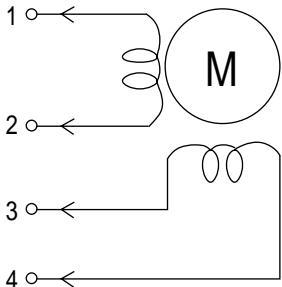
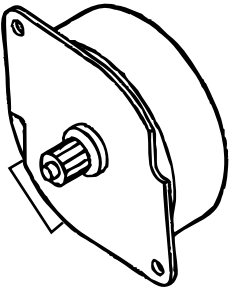

Figure 6.3

7. WIRING DIAGRAM

7.1 Resistance Check

Unit	Circuit Diagram	Illustration	Resistance
Transfer Belt Motor			<p>Between pins 1 and 2: 7.9Ω Between pins 3 and 4: 7.9Ω</p>
Main Motor (Y)			<p>Between pins 1 and 2: 2.4Ω Between pins 3 and 4: 2.4Ω</p>
Main Motor (M)			<p>Between pins 1 and 2: 2.4Ω Between pins 3 and 4: 2.4Ω</p>

Unit	Circuit Diagram	Illustration	Resistance
Main Motor (C)			<p>Between pins 1 and 2: 2.4Ω Between pins 3 and 4: 2.4Ω</p>
Main Motor (B)			<p>Between pins 1 and 2: 2.4Ω Between pins 3 and 4: 2.4Ω</p>
MT Resistration Motor			<p>Between pins 1 and 2: 7.9Ω Between pins 3 and 4: 7.9Ω</p>

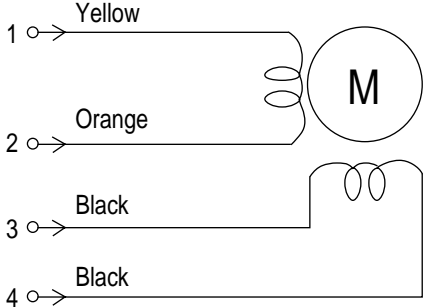
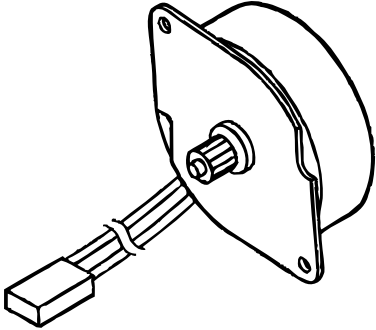
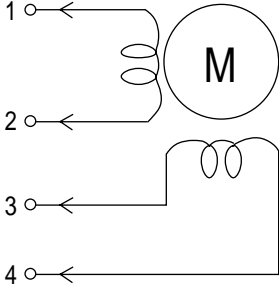
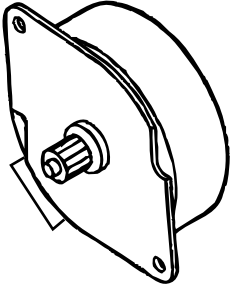
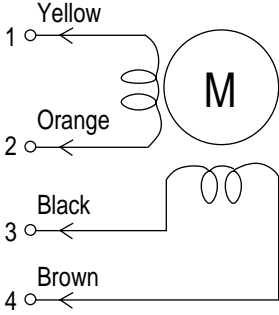
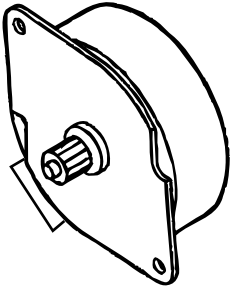
Unit	Circuit Diagram	Illustration	Resistance
Fuser Motor			<p>Between pins 1 and 2: 7.9Ω Between pins 3 and 4: 7.9Ω</p>
Feeder Motor			<p>Between pins 1 and 2: 7.9Ω or 8.4Ω Between pins 3 and 4: 7.9Ω or 8.4Ω</p>
Offset Motor			<p>Between pins 1 and 2: 23Ω Between pins 3 and 4: 23Ω</p>

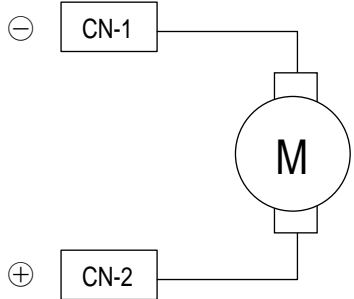
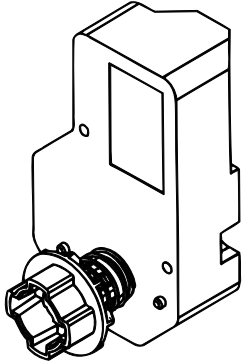
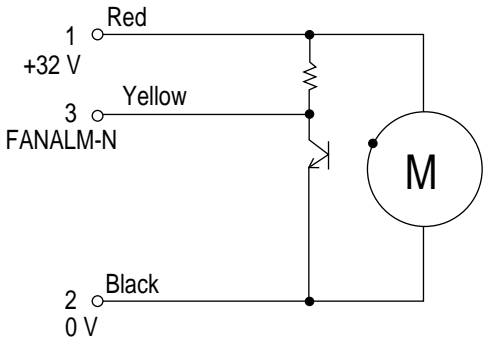
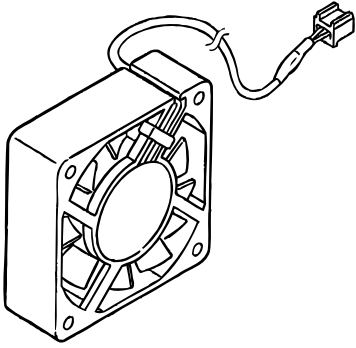
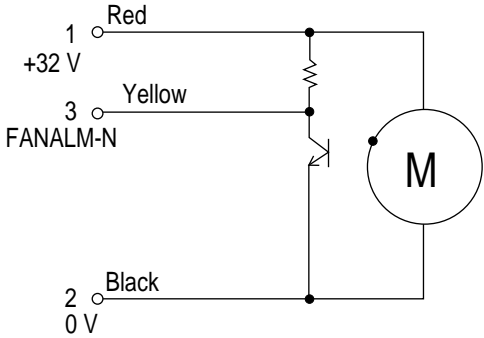
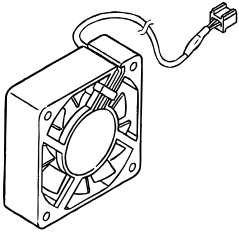
Unit	Circuit Diagram	Illustration	Resistance
Geared Motor			
CU Low-voltage Ejection Fuser Fan			
Low-voltage Absorption			

Unit	Circuit Diagram	Illustration	Resistance
CU Board			
ID and Fuser			
Fuser Unit			<p>① Between pins a and b: Between pins c and d: 231.4kΩ Between pins e and f: 231.4kΩ (at 25°C)</p> <p>② Between pins a and b: Between pins c and d: 0Ω or open Between pins e and f: 231.4kΩ (at 25°C)</p>

7.2 Parts Layout on Boards

(1) Print Engine Controller PWB (K73)

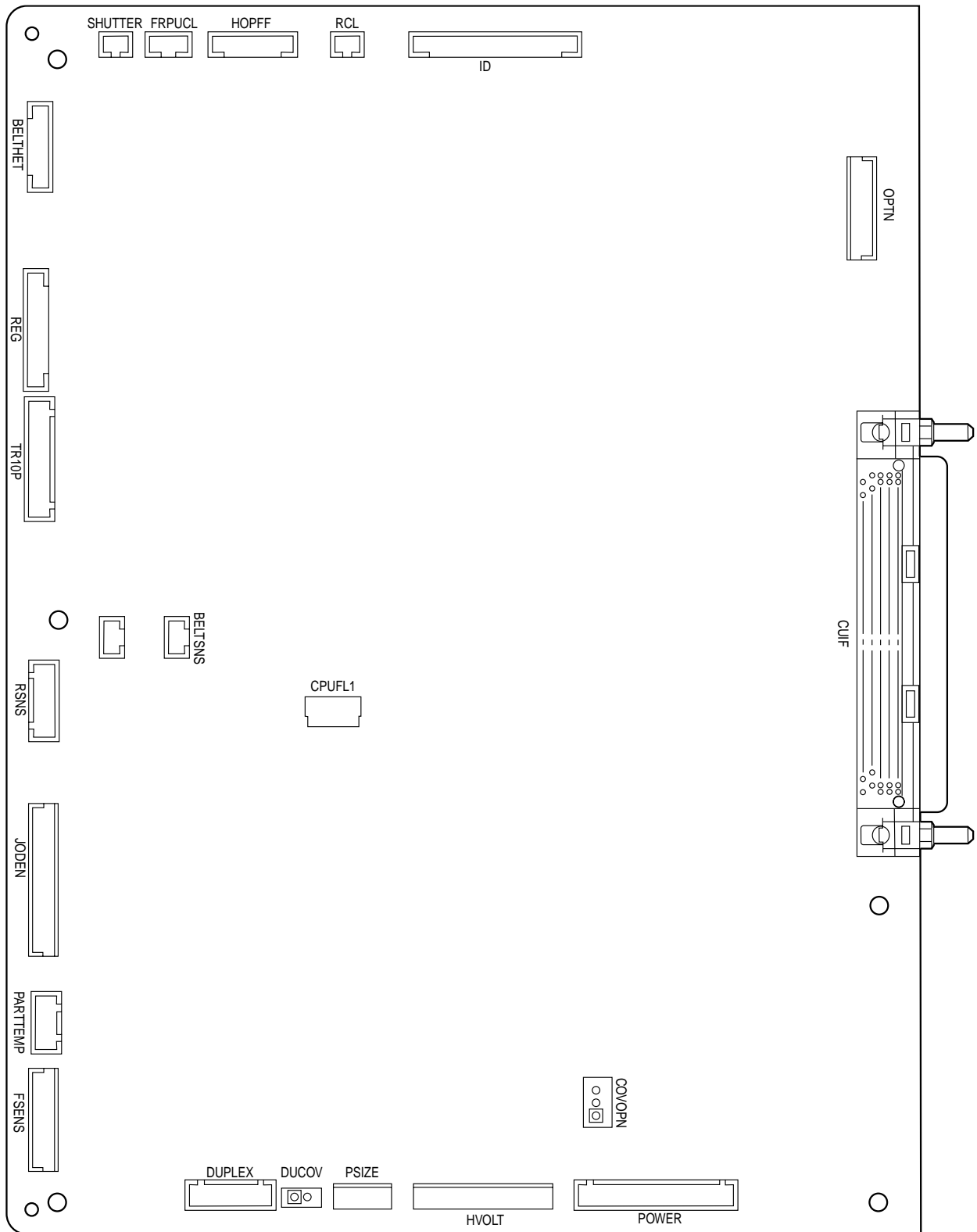

(2) Main Controller PWB: CRM

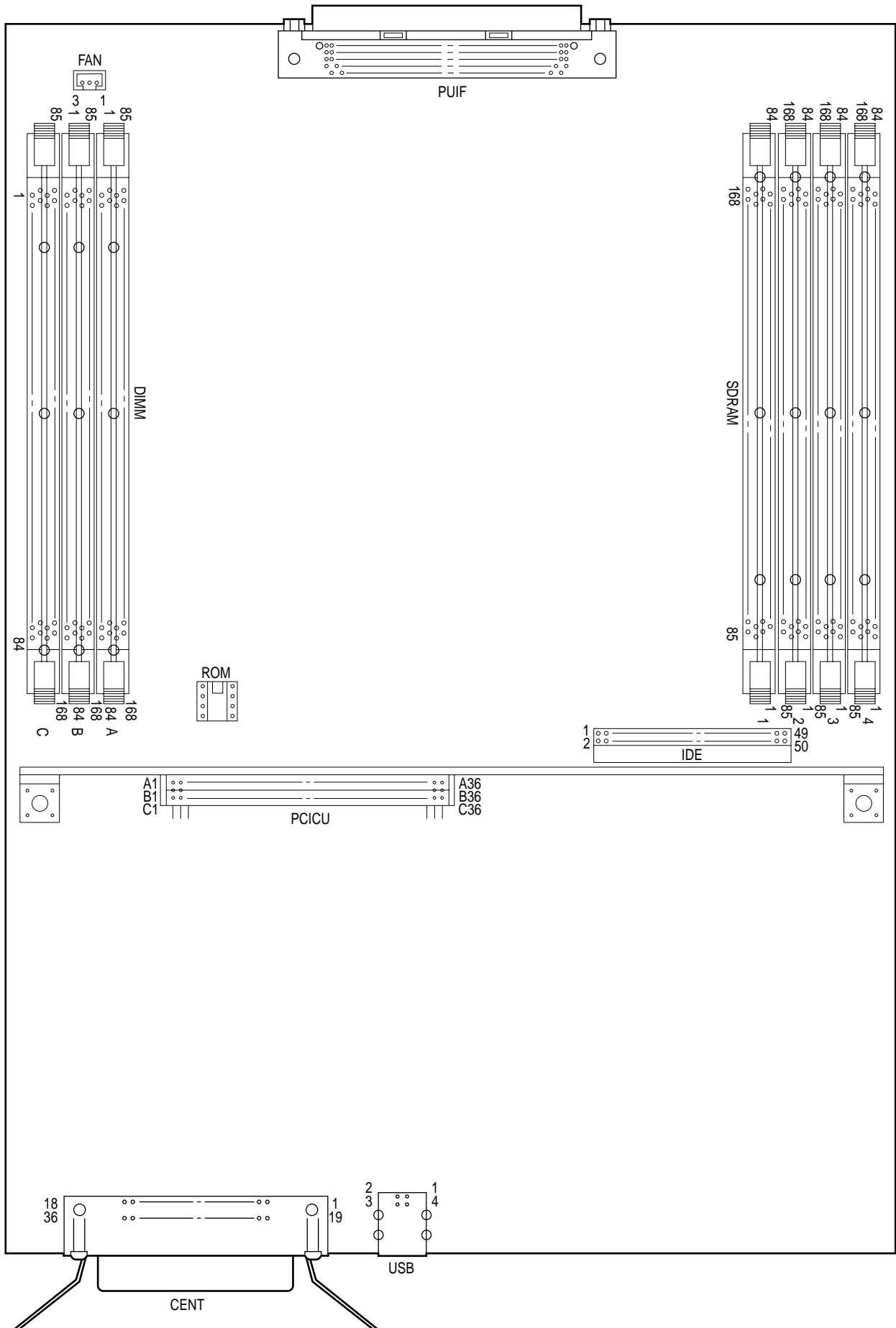

(3) LED Control PWB (Y71-2 PWB)

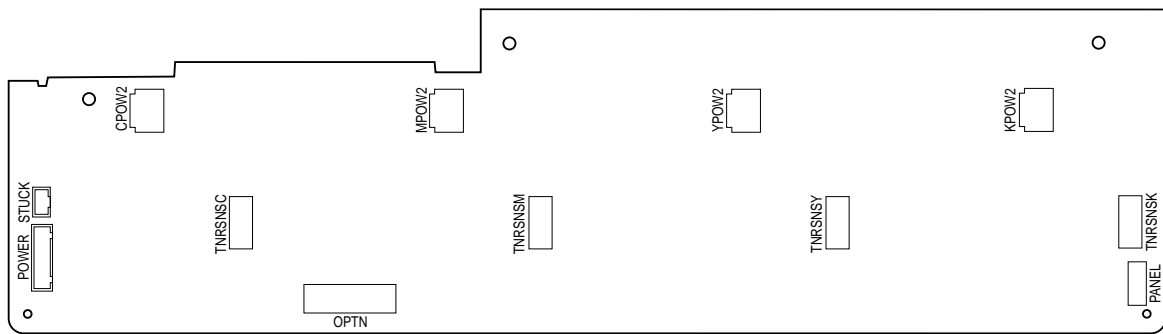

(4) Duplex Control PWB (V73- PWB)

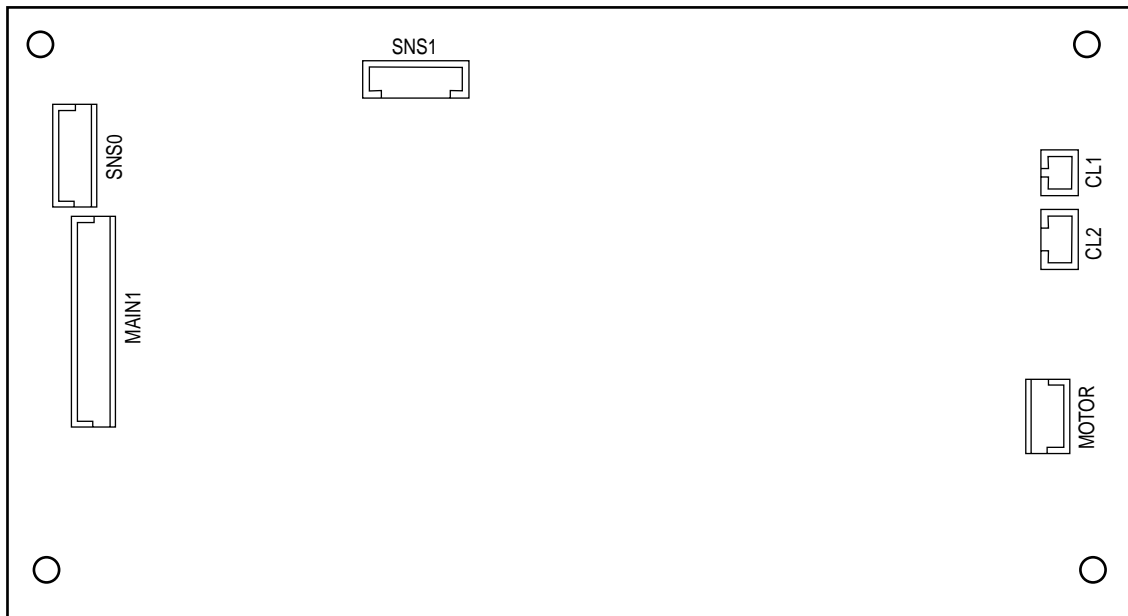

(5) Control Panel PWB (X71- PWB)

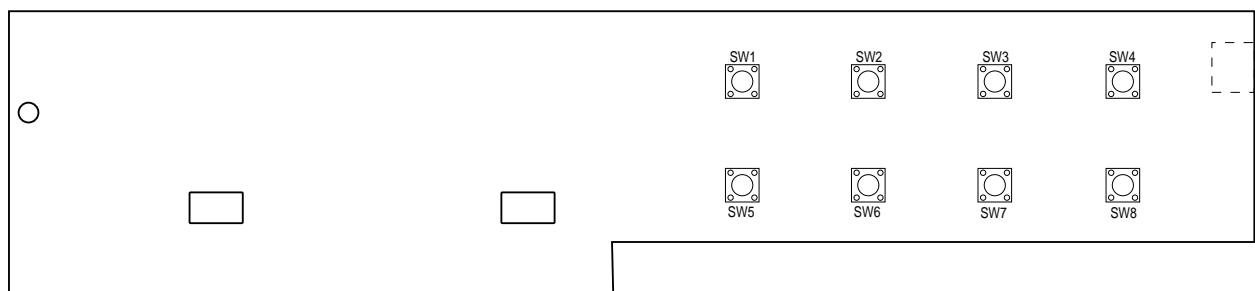

(6) N71-PWB

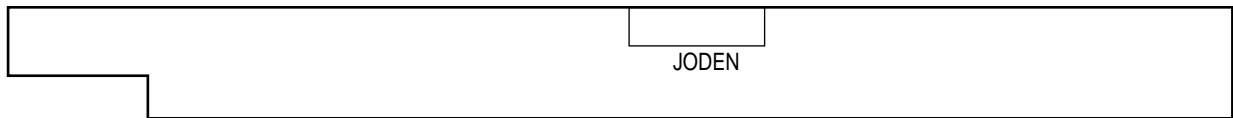

(7) Entrance Sensor PWB (R71- PWB)

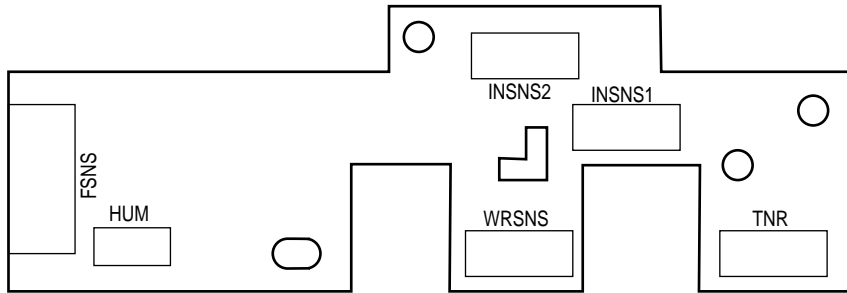

(8) Paper Size Sensing PWB PXC (B73- PWB)

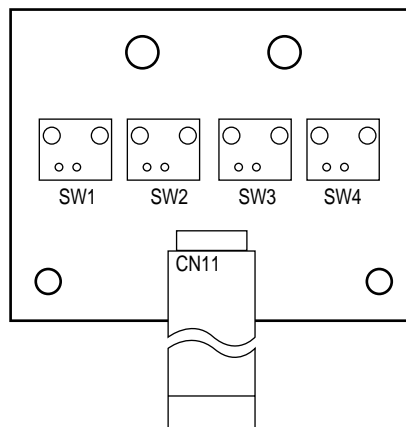

(9) Sensor PWB (A73-PWB)

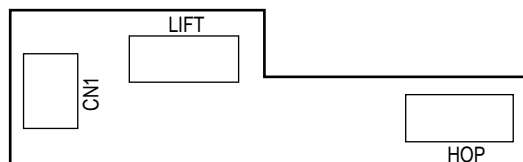

(10) Option I/F PWB (C73-PWB)

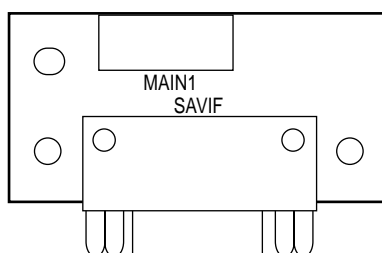

8. PARTS LIST

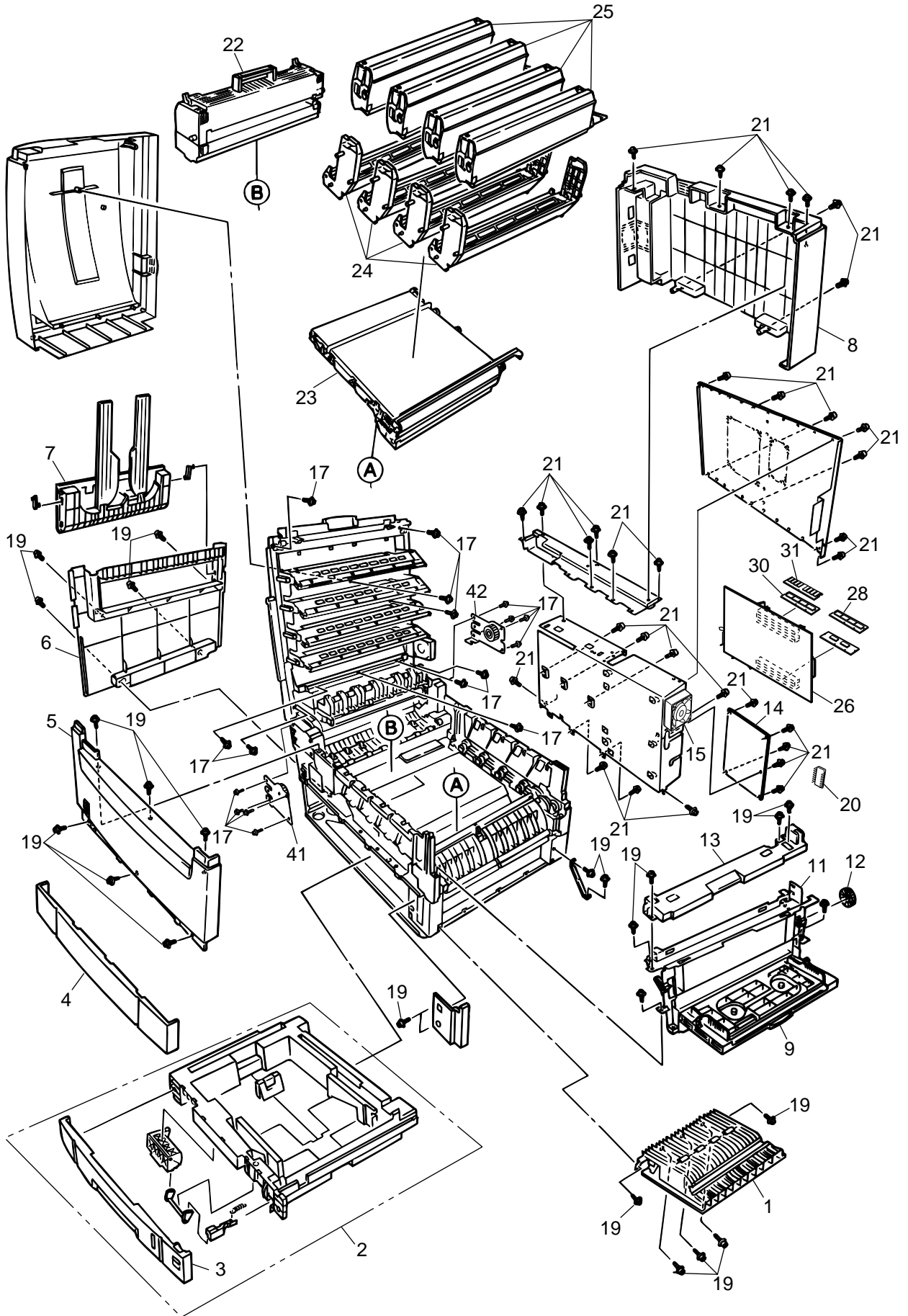

Figure 8-1-1/3

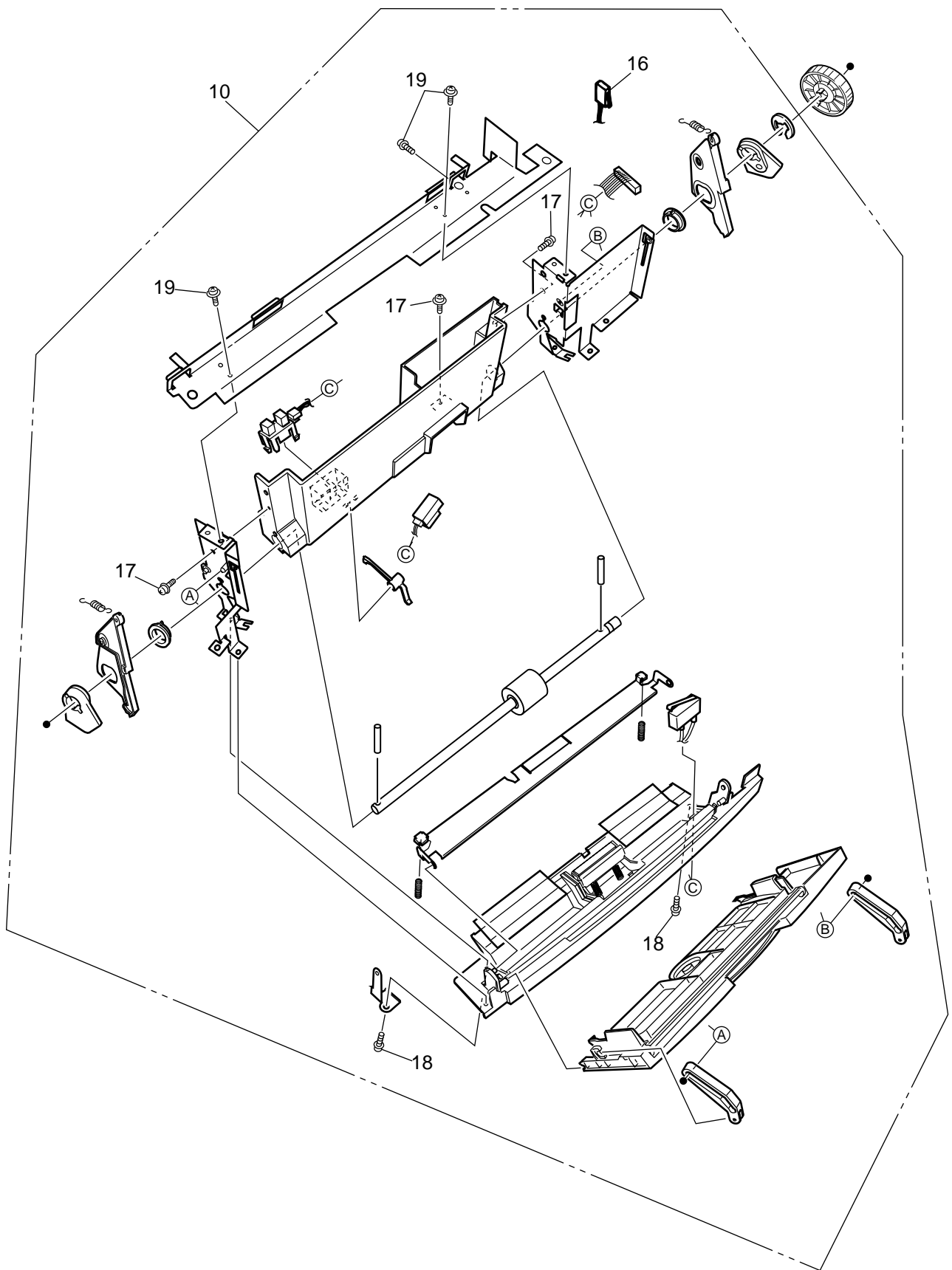

Figure 8-1-2/3

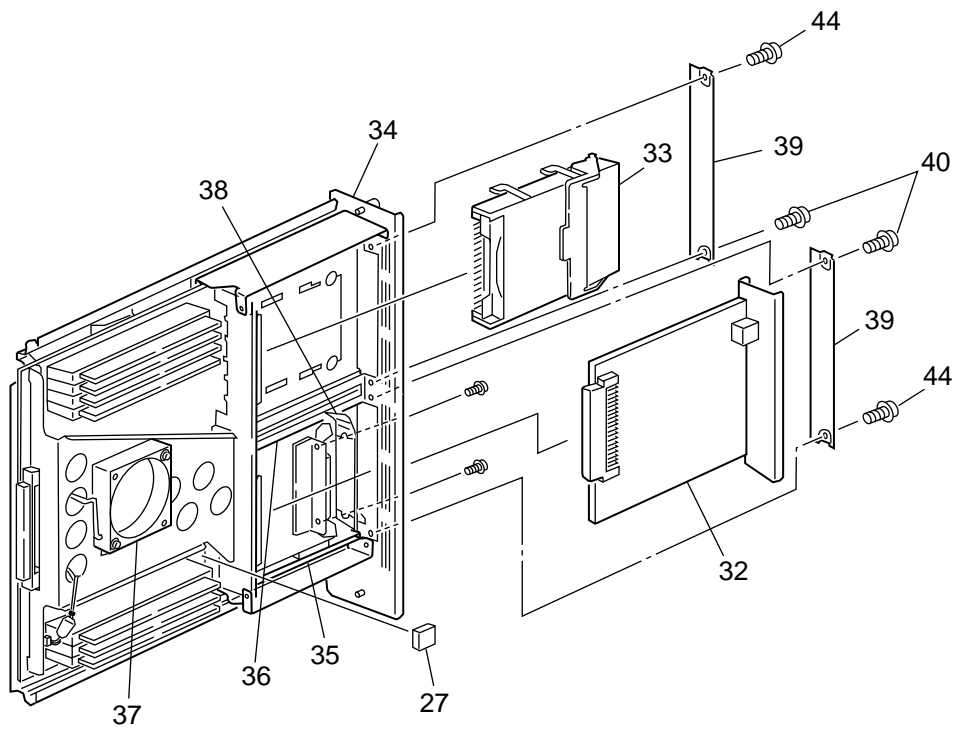

Figure 8-1-3/3

Table 8-1-1/3

Main Assembly

No.	Patrs No.	Name	Q'ty /Unit	Recommended Q'ty/Year			Remarks
				per 500	per 1000	per 2000	
1	41481201	Cover Assy-R	1	3	6	12	
2	41484905	Cassette Assy	1	3	6	12	
3	41353701	Cover-Front-CS	1	3	6	12	
4	41277901	Cover-Blank	1	3	6	12	
5	41276401	Cover-Front	1	3	6	12	
6	41277401	Cover-Side(L)	1	3	6	12	
7	41484201	Stacker-Face-Up Assy	1	3	6	12	
8	41276501	Cover-Rear	1	3	6	12	
9	41484601	Cover-Assy MT	1	3	6	12	
10	41493001	MPT Assy-703	1	3	6	12	
11	41297101	Plate-Top	1	3	6	12	
12	40325101	Gear-Z68	2	6	12	24	
13	41278001	Frame-Top	1	3	6	12	
14	41515108	Print Engine Controller PWB	1	3	6	12	1200dpi
	41515112	Print Engine Controller PWB	1	3	6	12	600dpi
15	41490702	Motor-Fan(80)	1	3	6	12	
16	41275702	Microswitch-Assy	1	3	6	12	
17	4PB4083-2500P008	Screw (T3×8)	20	-	-	-	
18	4PB4013-3100P008	Screw (M3×8)	2	-	-	-	
19	4PB4083-2500P010	Screw (T3×10)	24	-	-	-	
20	55943501	EEPROM	1	3	6	12	
21	4PB4013-3100P006	Screw (M3×6)	31	40	80	120	
22	41531401	Fuser-Unit	1	3	6	12	ODA(120V)
	N/A	Fuser-Unit	1	3	6	12	OEL/APS
	41531403	Fuser-Unit	1	3	6	12	ODA(230V)
23	41531501	Belt-Unit	1	3	6	12	ODA
	N/A	Belt-Unit	1	3	6	12	OEL/APS
24	41514705	ID-Y Type C3	1	-	-	-	ODA
	41514706	ID-M Type C3	1	-	-	-	ODA
	41514707	ID-C Type C3	1	-	-	-	ODA
	41514708	ID-K Type C3	1	-	-	-	ODA
	N/A	ID-Y Type C3	1	-	-	-	OEL
	N/A	ID-M Type C3	1	-	-	-	OEL
	N/A	ID-C Type C3	1	-	-	-	OEL
	N/A	ID-K Type C3	1	-	-	-	OEL

Table 8-1-2/3

No.	Patrs No.	Name	Q'ty /Unit	Recommended Q'ty/Year			Remarks
				per 500	per 1000	per 2000	
24	N/A	ID-Y Type C3	1	-	-	-	APS
	N/A	ID-M Type C3	1	-	-	-	APS
	N/A	ID-C Type C3	1	-	-	-	APS
	N/A	ID-K Type C3	1	-	-	-	APS
25	41515205	Toner-Cartridge_Type_C3_Y (15K)	1	-	-	-	ODA
	41515206	Toner-Cartridge_Type_C3_M (15K)	1	-	-	-	ODA
	41515207	Toner-Cartridge_Type_C3_C (15K)	1	-	-	-	ODA
	41515208	Toner-Cartridge_Type_C3_K (15K)	1	-	-	-	ODA
	N/A	Toner-Cartridge_Type_C3_Y (15K)	1	-	-	-	OEL
	N/A	Toner-Cartridge_Type_C3_M (15K)	1	-	-	-	OEL
	N/A	Toner-Cartridge_Type_C3_C (15K)	1	-	-	-	OEL
	N/A	Toner-Cartridge_Type_C3_K (15K)	1	-	-	-	OEL
	N/A	Toner-Cartridge_Type_C3_Y (15K)	1	-	-	-	APS
	N/A	Toner-Cartridge_Type_C3_M (15K)	1	-	-	-	APS
	N/A	Toner-Cartridge_Type_C3_C (15K)	1	-	-	-	APS
	N/A	Toner-Cartridge_Type_C3_K (15K)	1	-	-	-	APS
	N/A	Toner-Cartridge_Type_C3_Y (7.5K)	1	-	-	-	ODA
	N/A	Toner-Cartridge_Type_C3_M (7.5K)	1	-	-	-	ODA
	N/A	Toner-Cartridge_Type_C3_C (7.5K)	1	-	-	-	ODA
	N/A	Toner-Cartridge_Type_C3_K (7.5K)	1	-	-	-	ODA
	N/A	Toner-Cartridge_Type_C3_Y (7.5K)	1	-	-	-	OEL
	N/A	Toner-Cartridge_Type_C3_M (7.5K)	1	-	-	-	OEL
	N/A	Toner-Cartridge_Type_C3_C (7.5K)	1	-	-	-	OEL
	N/A	Toner-Cartridge_Type_C3_K (7.5K)	1	-	-	-	OEL
	N/A	Toner-Cartridge_Type_C3_Y (7.5K)	1	-	-	-	APS
	N/A	Toner-Cartridge_Type_C3_M (7.5K)	1	-	-	-	APS
	N/A	Toner-Cartridge_Type_C3_C (7.5K)	1	-	-	-	APS
	N/A	Toner-Cartridge_Type_C3_K (7.5K)	1	-	-	-	APS
26	41356019	PCB Assy-CRM	1	3	6	12	1200dpi
	41356020	PCB Assy-CRM	1	3	6	12	600dpi
27	8164323M0000	EEPROM(CU)	1	3	6	12	
28	41469504	Board-TNY	1	3	6	12	
29							

Table 8-1-3/3

No.	Patrs No.	Name	Q'ty /Unit	Recommended Q'ty/Year			Remarks
				per 500	per 1000	per 2000	
30	41437418	Board-Memory 64MB	1	3	6	12	600dpi-ODA
	N/A	Board-Memory 64MB	1	3	6	12	600dpi-OEL
	N/A	Board-Memory 64MB	1	3	6	12	600dpi-APS
	41437419	Board-Memory 128MB	1	3	6	12	600dpi Duplex-ODA,1200dpi-ODA
	N/A	Board-Memory 128MB	1	3	6	12	600dpi Duplex-OEL,1200dpi-OEL
	N/A	Board-Memory 128MB	1	3	6	12	600dpi Duplex-APS,1200dpi-APS
	41437420	Board-Memory 256MB	1	3	6	12	1200dpi Duplex-ODA
	N/A	Board-Memory 256MB	1	3	6	12	1200dpi Duplex-OEL
	N/A	Board-Memory 256MB	1	3	6	12	1200dpi Duplex-APS
31	41437418	Board-Memory 64MB	1	3	6	12	1200dpi-ODA
	41437414	Board-Memory 64MB	1	3	6	12	1200dpi-OEL
	41437410	Board-Memory 64MB	1	3	6	12	1200dpi-APS
32	41376902	Board-MLETB09	(1)	(3)	(6)	(12)	Option-OEL
	41437302	Board-MLETB09	(1)	(3)	(6)	(12)	Option-APS
33	41376005	HDD Assy	(1)	(3)	(6)	(12)	Option-ODA
	41376004	HDD Assy	(1)	(3)	(6)	(12)	Option-OEL
	41376002	HDD Assy	(1)	(3)	(6)	(12)	Option-APS
34	41286901	Plate Shield	1	3	6	12	
35	41278601	Guide -Rail(A)	2	6	12	28	
36	41278701	Guide -Rail(B)	1	3	6	12	
37	41410201	Motor-Fan	1	3	6	12	
38	41467401	Plate-FG(Centro)	1	3	6	12	
39	41254601	Plate-blank	2	6	12	28	
40	41278401	Screw	2	5	10	20	
41	41366501	Limiter-2Way(Front)	1	3	6	12	
42	41366601	Limiter-2Way(Rear)	1	3	6	12	
43							
44	41723901	Screw	2	-	-	-	

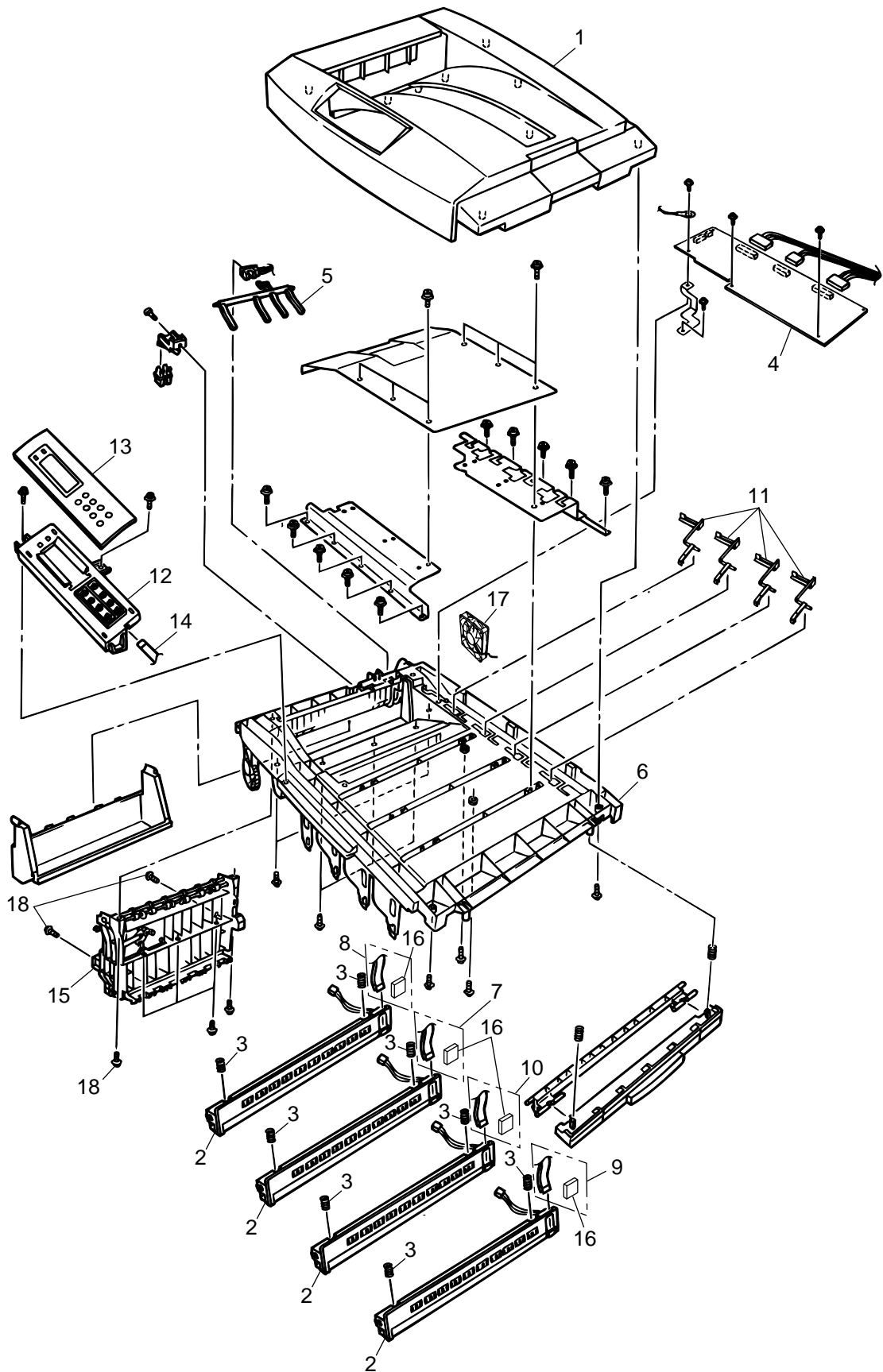

Figure 8-2

Table 8-2

Top Cover Assembly

No.	Parts No.	Name	Q'ty /Unit	Recommended Q'ty/Year			Remarks
				per 500	per 1000	per 2000	
1	41484401	Cover Assy-Stacker	1	3	6	12	
2	41502301	LED Assy 1200dpi	4	12	24	48	ODA/OEL/APS
	41502302	LED Assy 600dpi	4	12	24	48	ODA/OEL/APS
3	40861001	LED Assy Spring	8	24	48	96	
4	41257902	LED control PWB	1	3	6	12	
5	41349801	Lever Stacker Full	1	3	6	12	
6	41487101	Cover Assy-Inn(Sub)	1	3	6	12	
7	41514103	LED Harness M	1	3	6	12	
8	41514104	LED Harness C	1	3	6	12	
9	41514101	LED Harness K	1	3	6	12	
10	41514102	LED Harness Y	1	3	6	12	
11	41703701	Sensor-Assy-Tonner	4	12	24	48	
12	41484501	Control Panel Assy	1	3	6	12	
13	40866207	Control Panel Bezel	1	3	6	12	1200dpi
	40866211	Control Panel Bezel	1	3	6	12	600dpi
14	2381005P0024	Control Panel Tape Harness	1	3	6	12	
15	41484701	Eject Guide Assy	1	3	6	12	
16	2251001P0260	26pin LED Connector	4	12	24	48	
17	40255202	Motor-Fan(80-25)	1	3	6	12	
18	4PB4083-2500P008	Screw (T3x8)	19	-	-	-	

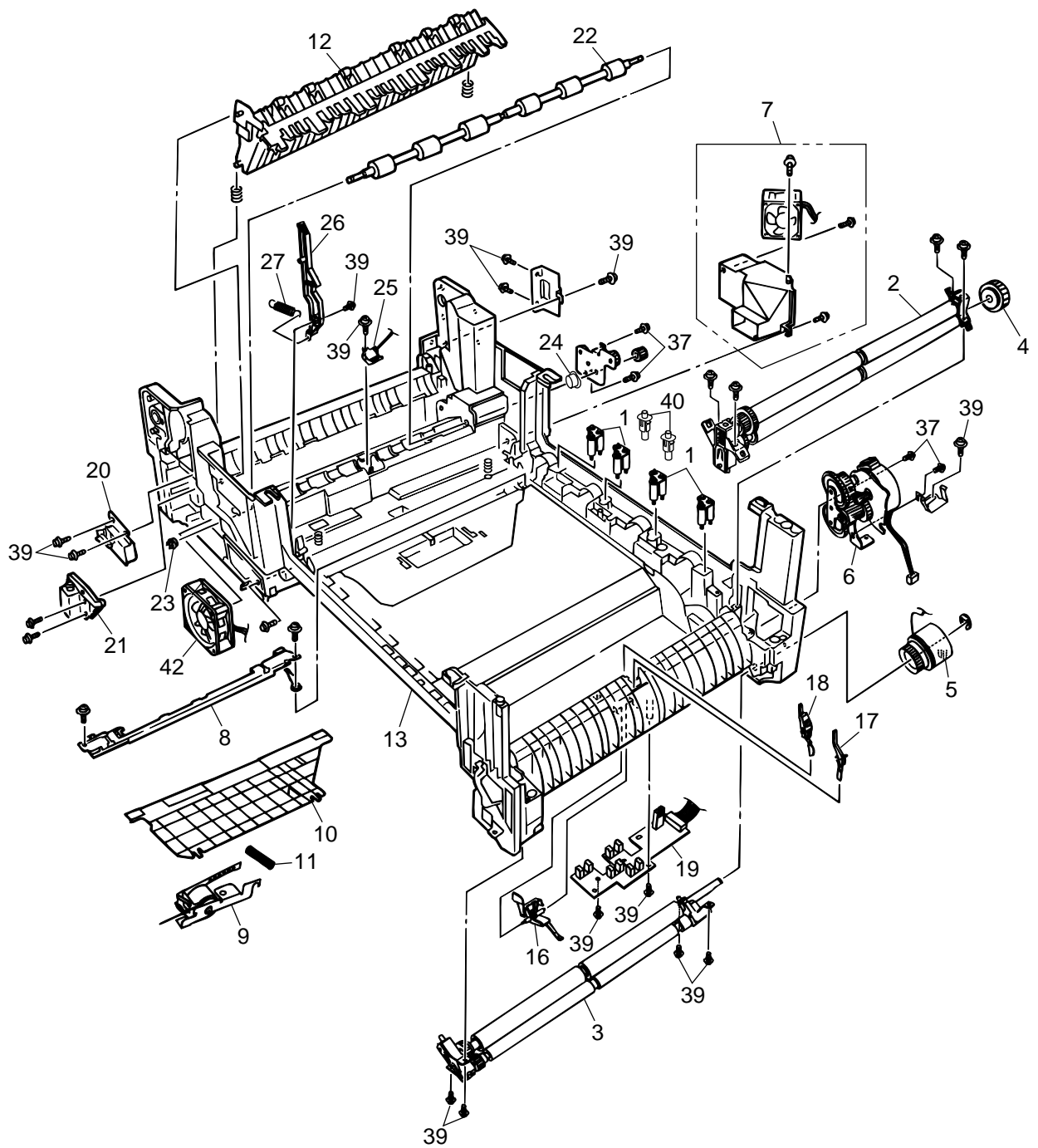

Figure 8-3-1/2

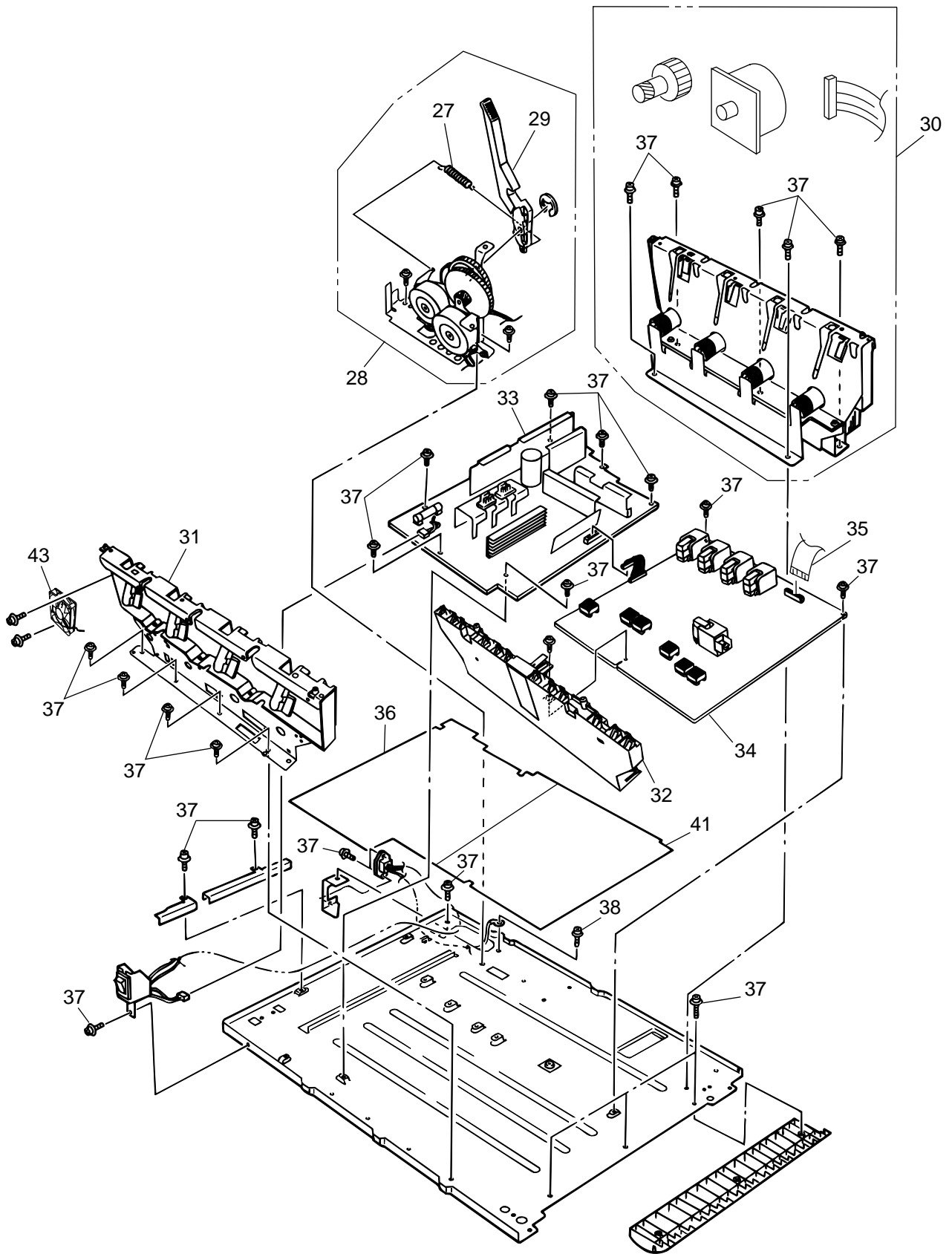

Figure 8-3-2/2

Table 8-3-1/2

Printer Unit Chassis

No.	Parts No.	Name	Q'ty /Unit	Recommended Q'ty/Year			Remarks
				per 500	per 1000	per 2000	
1	41189701	Drum contact Assy	4	12	24	48	
2	41483201	Registration Roller Assy (A)	1	3	6	12	
3	41483301	Registration Roller Assy (B)	1	3	6	12	
4	40845401	Registration Drive Gear (A)	1	3	6	12	
5	41187101	Registration Clutch	1	3	6	12	
6	41483401	Registration Motor Assy	1	3	6	12	
7	41483701	Motor-Assy-Fan	1	3	6	12	
8	41491001	Color Registration Sensor Assy	1	3	6	12	
9	41744001	Registration Shutter Solenoid	1	3	6	12	
10	41743901	Registration Shutter	1	3	6	12	
11	41744601	Registration Shutter Spring	1	3	6	12	
12	41486801	Duplex Guide Assy	1	3	6	12	
13	41483101	Printer Unit Chassis	1	3	6	12	
14							
15							
16	40841601	Entrance Cassette Sensor Actuator	1	3	6	12	
17	41578501	Entrance MT Sensor Actuator	1	3	6	12	
18	40841801	Entrance Belt Sensor Actuator	1	3	6	12	
19	41258301	Board R71	1	3	6	12	
20	41486601	Magnet-Assy-Dup	1	3	6	12	
21	41393901	Solenoid sheet Assy	1	3	6	12	
22	41095901	Roller Feed(C)	1	3	6	12	
23	51607301	Fuser Exit Roller Bushing (L)	1	3	6	12	
24	51609401	Fuser Exit Roller Bushing (R)	1	3	6	12	
25	41073601	Exit Sensor Assy	1	3	6	12	
26	40841301	Fuser Latching Handle (L)	1	3	6	12	
27	41628301	Fuser Latching Handle Spring	2	6	12	24	
28	41483901	Transfer Belt Motor Assy	1	3	6	12	
29	40841401	Fuser Latching Handle (R)	1	3	6	12	
30	41483801	Main Motor Assy	1	3	6	12	
31	41484001	Left Plate Assy	1	3	6	12	
32	40850201	Contact Assy	1	3	6	12	
33	41303401	PWR Unit-ACDC Switch 120V	1	3	6	12	
	41303501	PWR Unit-ACDC Switch 230V	1	3	6	12	
34	40737601	Power Unit(High-Voltage)	1	3	6	12	

Table 8-3-2/2

No.	Parts No.	Name	Q'ty /Unit	Recommended Q'ty/Year			Remarks
				per 500	per 1000	per 2000	
35	56732302	HV Tape Harness	1	3	6	12	
36	41500101	Power Supply Insulation	1	3	6	12	
37	4PB4013-3100P006	Screw (M3×6)	26	-	-	-	
38	PSW4-8C	Screw (M4×8)	1	-	-	-	
39	4PB4083-2500P008	Screw (T3×8)	29	-	-	-	
40	41346301	Transfer Contact Assy	2	6	12	24	
41	41589501	Power Supply Insulation(HV)	1	3	6	12	
42	40197103	FAN-Power Supply (PUSH)	1	3	6	12	
43	41431602	FAN-Left Plate (PUSH)	1	3	6	12	

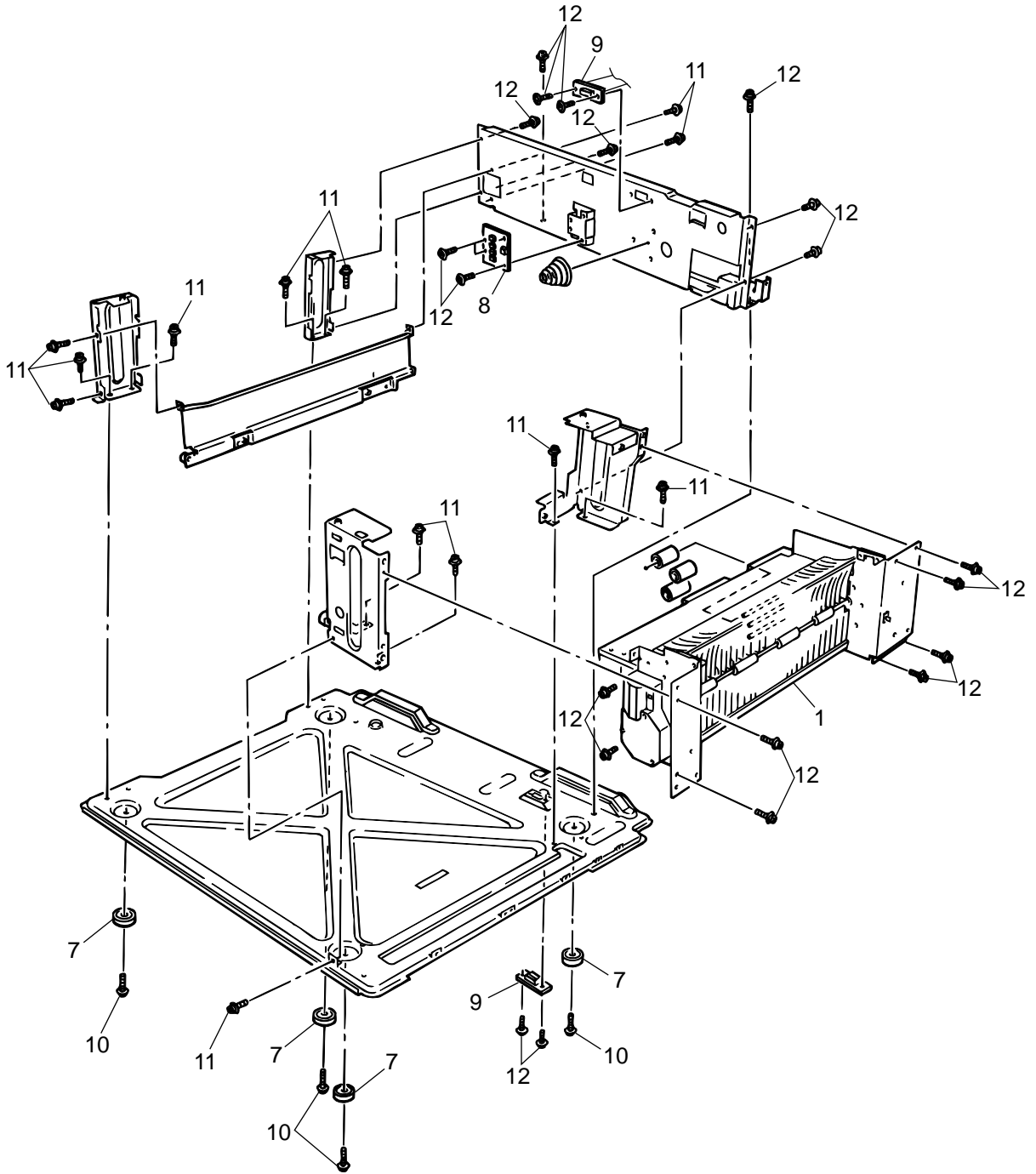

Figure 8-4-1/2

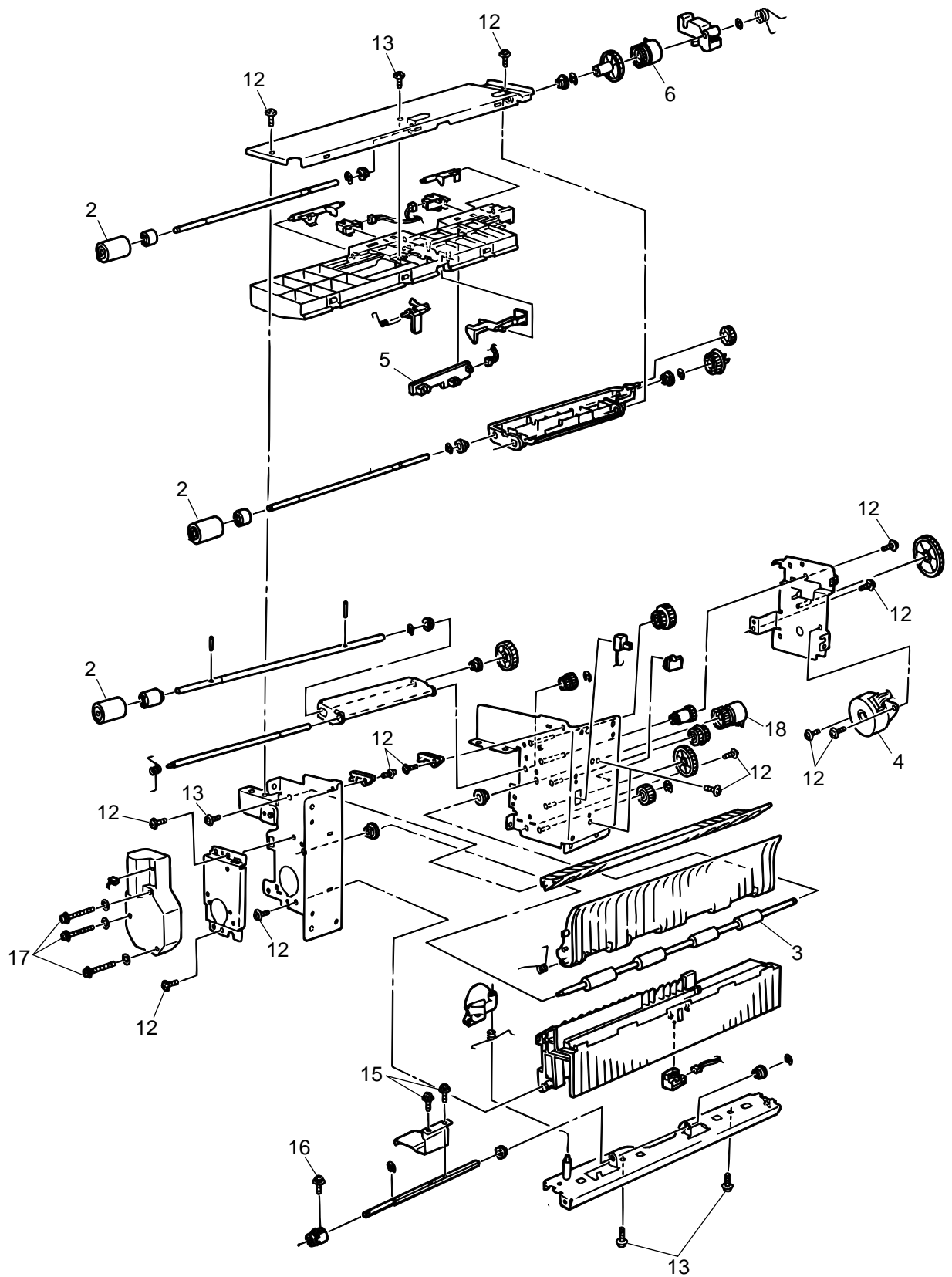

Figure 8-4-2/2

Table 8-4

Paper Tray Guide

No.	Parts No.	Name	Q'ty /Unit	Recommended Q'ty/Year			Remarks
				per 500	per 1000	per 2000	
1	41481301	Guide-Assy-R-1st	1	3	6	12	
2	41481701	Roller-Feed	1	3	6	12	
3	41488401	Roller-Feed-A3	1	3	6	12	
4	41529101	Motor-Pulse(Hop)	1	3	6	12	
5	41515701	Board-A73	1	3	6	12	
6	41503001	Gear Assy-Clutch(2pin)	1	3	6	12	
7	41502601	Rubber Foot	4	12	24	48	
8	41515801	Paper Size Sensing PWB	1	3	6	12	
9	56731640	Connector	1	3	6	12	
10	4PB4013-3101P006	Screw (T4×6)	4	-	-	-	
11	4PB4013-3101P008	Screw (T4×8)	27	-	-	-	
12	4PB4013-3100P008	Screw (M3×8)	18	-	-	-	
13	4PB4083-2500P010	Screw T3×10	4	-	-	-	
14							
15	PSW2W3-10C	Screw	2	-	-	-	
16	PSW2W3-16C	Screw	1	-	-	-	
17	PSW2W3-20C	Screw	3	-	-	-	
18	41488301	Gear Assy-Clutch(3pin)	1	3	6	12	

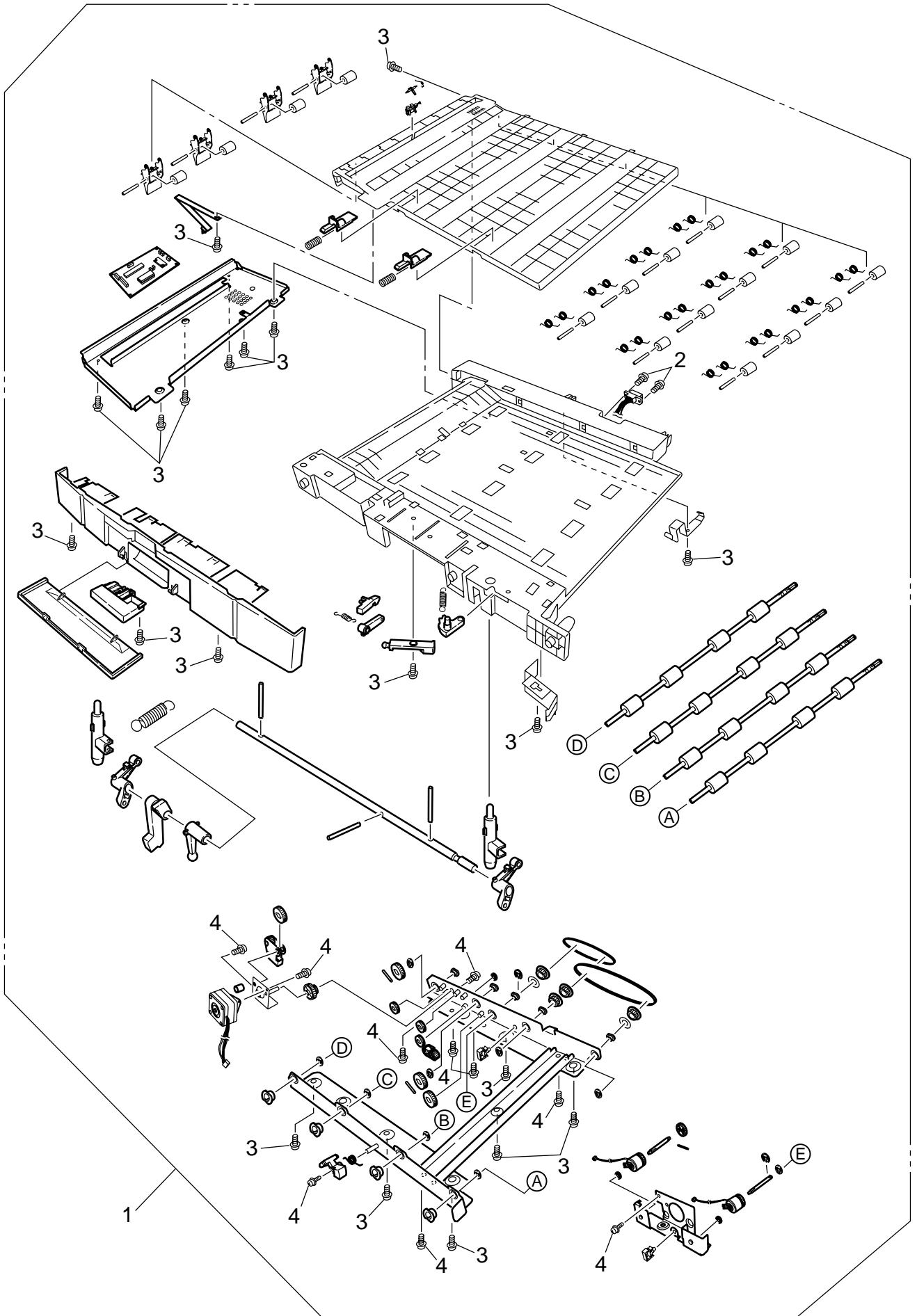

Figure 8-5

Table 8-5

Duplex Unit

No.	Parts No.	Name	Q'ty /Unit	Recommended Q'ty/Year			Remarks
				per 500	per 1000	per 2000	
1	41178201	Duplex Assy	1	-	-	-	ODA
	41178203	Duplex Assy	1	-	-	-	OEL
	41178207	Duplex Assy	1	-	-	-	APS
2	4PB4043-4718P001	Screw (SP3×10)	2	-	-	-	
3	4PB4083-2500P008	Screw (T3×8)	21	-	-	-	
4	4PB4013-3100P006	Screw (M3×6)	9	-	-	-	

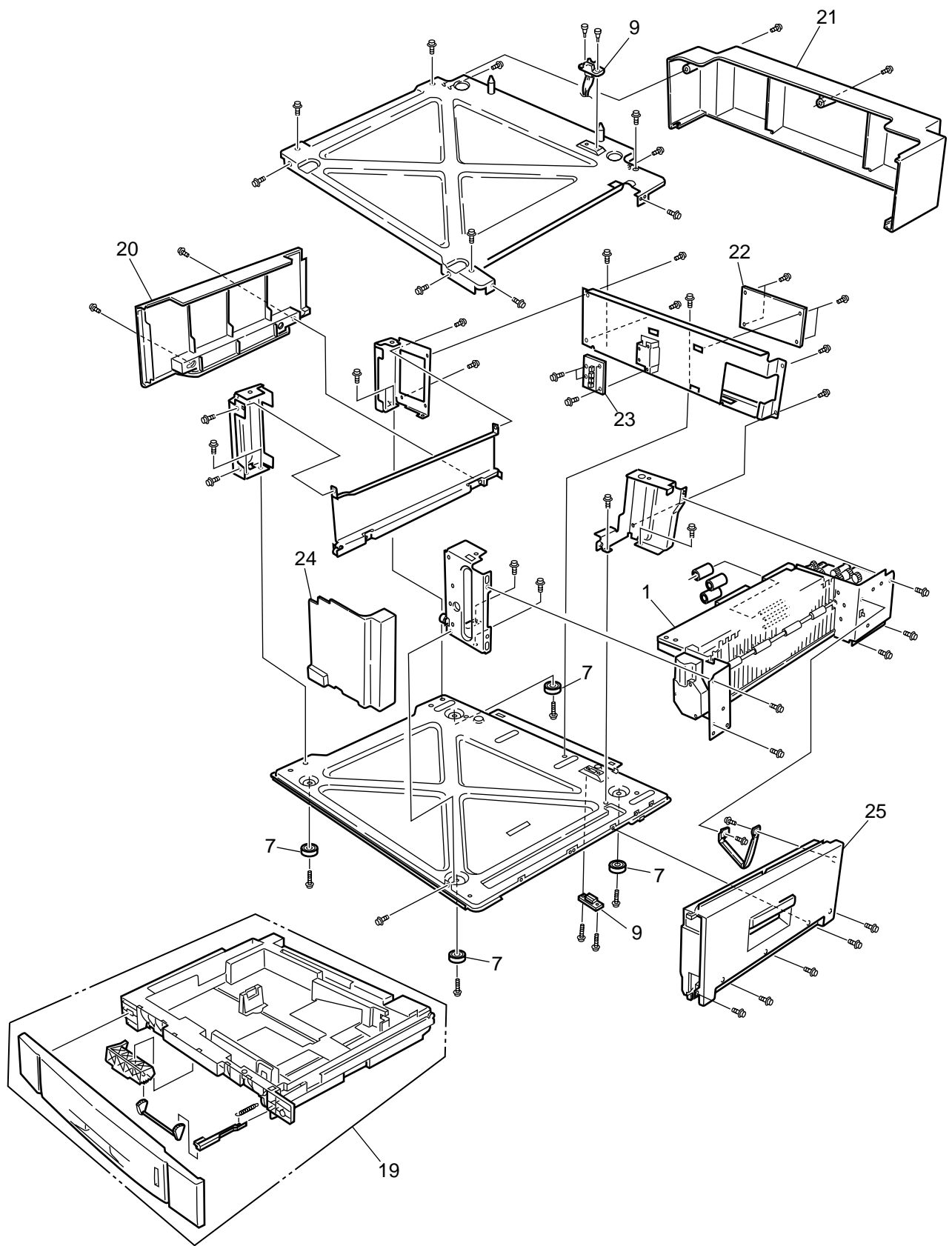
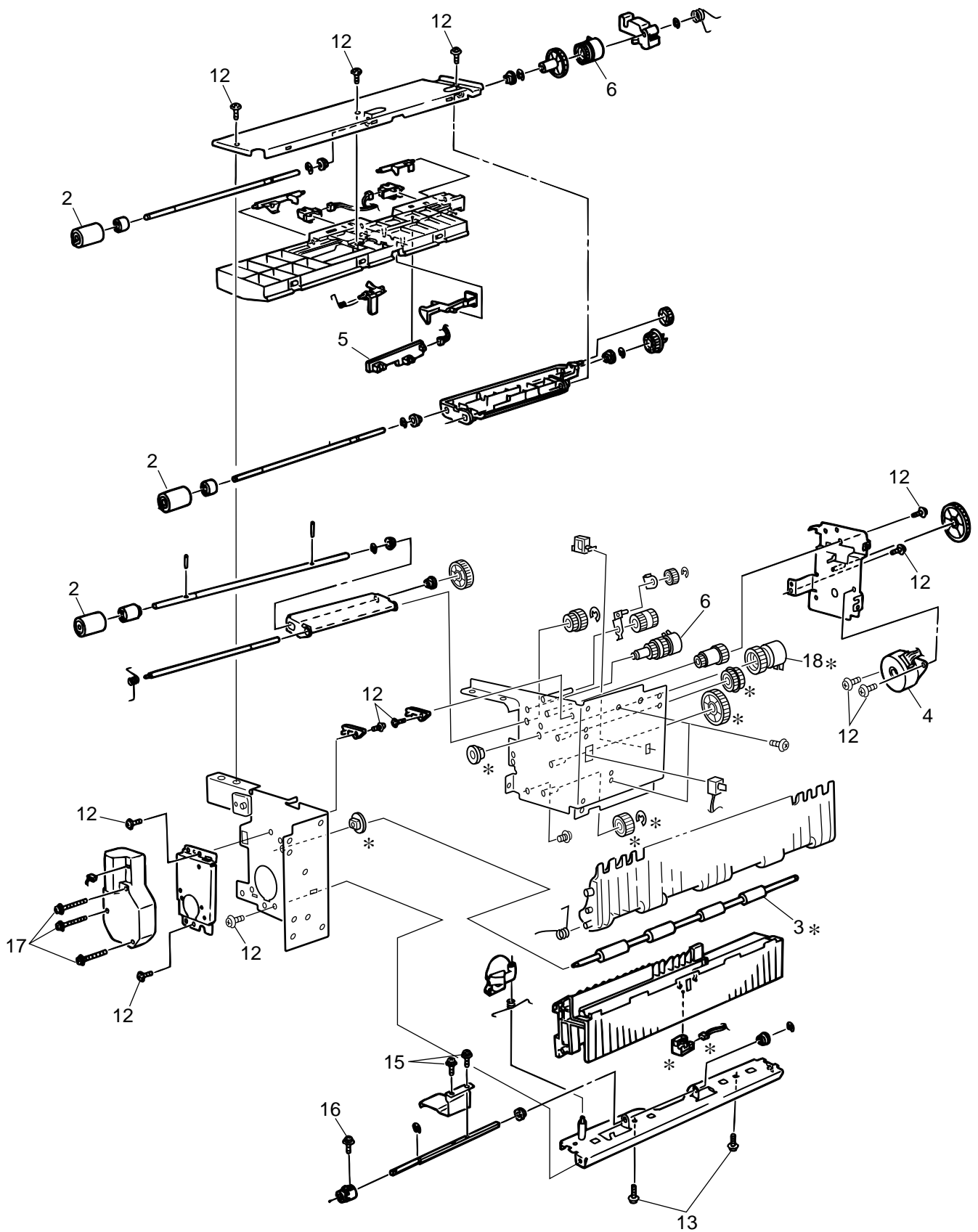

Figure 8-6-1/2



* These parts are not attached to the lowest tray.

Figure 8-6-2/2

High Capacity Tray Unit, 2nd/3rd Tray Unit

No.	Parts No.	Name	Q'ty /Unit	Recommended Q'ty/Year			Remarks
				per 500	per 1000	per 2000	
1	41481301	Guide R Assy	1	3	6	12	
2	41481701	Roller-Feed	3	9	18	36	
3	41488401	Roller-Feed (A3)	1	3	6	12	
4	41529101	Motor-Hopping	1	3	6	12	
5	41515701	Board A73	1	3	6	12	
6	41503001	Clutch Guide Assy (2 pin)	1	3	6	12	
7	41502601	Rubber-Foot	4	12	24	48	
8							
9	2201000P140	Connector	1	3	6	12	
10	4PB4013-3101P006	Screw (T4×6)	4	-	-	-	
11	4PB4013-3101P008	Screw (T4×8)	27	-	-	-	
12	4PB4013-3100P008	Screw (M3×8)	18	-	-	-	
13	4PB4083-2500P010	Screw (T3×10)	4	-	-	-	
14							
15	PSW2W3-10C	Screw	2	-	-	-	
16	PSW2W3-16C	Screw	1	-	-	-	
17	PSW2W3-20C	Screw	3	-	-	-	
18	41488301	Clutch Guide Assy (3 pin)	1	3	6	12	
19	41547805	Cassette Assy	1	3	6	12	
20	41503601	Cover-Side L	1	3	6	12	
21	41503801	Cover-Rear	1	3	6	12	
22	41463003	Board V73	1	3	6	12	
23	41515801	Paper Size sensor	1	3	6	12	
24	41503701	Cover-Side R Sub	1	3	6	12	
25	41481201	Cover-Side R Assy	1	3	6	12	